NORTH ATLANTIC TREATY
ORGANIZATION



AC/323(SET-182)TP/695

SCIENCE AND TECHNOLOGY
ORGANIZATION



www.sto.nato.int

STO TECHNICAL REPORT

TR-SET-182

Radar Spectrum Engineering and Management

(Ingénierie et gestion du spectre radar)

Final Report of Task Group SET-182.

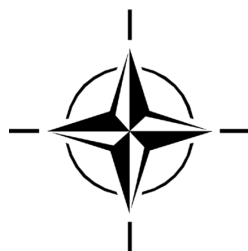

Published April 2016

Distribution and Availability on Back Cover



NORTH ATLANTIC TREATY
ORGANIZATION



AC/323(SET-182)TP/695

SCIENCE AND TECHNOLOGY
ORGANIZATION



www.sto.nato.int

STO TECHNICAL REPORT

TR-SET-182

Radar Spectrum Engineering and Management

(Ingénierie et gestion du spectre radar)

Final Report of Task Group SET-182.

The NATO Science and Technology Organization

Science & Technology (S&T) in the NATO context is defined as the selective and rigorous generation and application of state-of-the-art, validated knowledge for defence and security purposes. S&T activities embrace scientific research, technology development, transition, application and field-testing, experimentation and a range of related scientific activities that include systems engineering, operational research and analysis, synthesis, integration and validation of knowledge derived through the scientific method.

In NATO, S&T is addressed using different business models, namely a collaborative business model where NATO provides a forum where NATO Nations and partner Nations elect to use their national resources to define, conduct and promote cooperative research and information exchange, and secondly an in-house delivery business model where S&T activities are conducted in a NATO dedicated executive body, having its own personnel, capabilities and infrastructure.

The mission of the NATO Science & Technology Organization (STO) is to help position the Nations' and NATO's S&T investments as a strategic enabler of the knowledge and technology advantage for the defence and security posture of NATO Nations and partner Nations, by conducting and promoting S&T activities that augment and leverage the capabilities and programmes of the Alliance, of the NATO Nations and the partner Nations, in support of NATO's objectives, and contributing to NATO's ability to enable and influence security and defence related capability development and threat mitigation in NATO Nations and partner Nations, in accordance with NATO policies.

The total spectrum of this collaborative effort is addressed by six Technical Panels who manage a wide range of scientific research activities, a Group specialising in modelling and simulation, plus a Committee dedicated to supporting the information management needs of the organization.

- AVT Applied Vehicle Technology Panel
- HFM Human Factors and Medicine Panel
- IST Information Systems Technology Panel
- NMSG NATO Modelling and Simulation Group
- SAS System Analysis and Studies Panel
- SCI Systems Concepts and Integration Panel
- SET Sensors and Electronics Technology Panel

These Panels and Group are the power-house of the collaborative model and are made up of national representatives as well as recognised world-class scientists, engineers and information specialists. In addition to providing critical technical oversight, they also provide a communication link to military users and other NATO bodies.

The scientific and technological work is carried out by Technical Teams, created under one or more of these eight bodies, for specific research activities which have a defined duration. These research activities can take a variety of forms, including Task Groups, Workshops, Symposia, Specialists' Meetings, Lecture Series and Technical Courses.

The content of this publication has been reproduced directly from material supplied by STO or the authors.

Published April 2016

Copyright © STO/NATO 2016
All Rights Reserved

ISBN 978-92-837-2095-9

Single copies of this publication or of a part of it may be made for individual use only by those organisations or individuals in NATO Nations defined by the limitation notice printed on the front cover. The approval of the STO Information Management Systems Branch is required for more than one copy to be made or an extract included in another publication. Requests to do so should be sent to the address on the back cover.

Table of Contents

	Page
List of Figures	vii
List of Tables	x
List of Acronyms	xi
SET-182 Membership List	xv
Executive Summary and Synthèse	ES-1
Chapter 1 – Introduction	1-1
1.1 Context	1-1
1.1.1 Adjacent-Band Interference Mitigation for Radar Emissions	1-2
1.1.2 Adaptive/Cognitive Emission Control	1-5
1.1.3 Electromagnetic Compatibility (EMC)	1-6
1.1.4 Receiver Interference Rejection	1-6
1.2 Objectives	1-7
1.3 Study Organization	1-7
1.4 Report Structure	1-7
Chapter 2 – Improved Transmitter Spectral Purity	2-1
2.1 Introduction	2-1
2.2 Background on Spectral Cleanliness	2-3
2.2.1 Spectrally Clean Waveform Formulation	2-4
2.2.2 Spectrally Clean Transmitter Design	2-7
2.2.3 Other Recent and Current Efforts on Improving Transmitter Spectral Cleanliness	2-10
2.2.4 Technology Watch: Adaptive Solid-State Power Amplifiers and Optimized Waveforms	2-11
2.2.4.1 Description of the Technology	2-11
2.2.4.2 Possible Impact of the Technology on a Military Capability	2-12
2.2.4.3 Technology Readiness Level	2-13
2.2.4.4 Related to NATO Requirements	2-13
2.3 Controlling the Pulse Rise/Fall Time	2-13
2.3.1 LiNC-PCFM Radar Implementation	2-14
2.4 Reconfigurable Amplifier Design for Flexible Spectral Mask Compliance	2-18
2.4.1 Fast Load-Impedance Search for Power-Added Efficiency and Adjacent-Channel Power Ratio	2-19
2.4.2 Load Impedance Optimization Based Directly on PAE and Spectral Mask Compliance	2-24
2.4.3 The Smith Tube for Joint Circuit and Waveform Design	2-27

2.4.4	Next Steps in Joint Circuit and Waveform Optimization for Spectrally Sensitive, Adaptive Radar	2-31
-------	--	------

Chapter 3 – Better Receivers **3-1**

3.1	Introduction	3-1
3.2	Basic Analog Radar Receiver Topology	3-1
3.3	Dynamic Range	3-2
3.4	Mixers and Downconversion	3-3
3.5	Analog Coherent Detection	3-4
3.6	Digital Coherent Detection	3-5

Chapter 4 – Passive Bistatic Radar **4-1**

4.1	Background	4-1
4.2	Commensal Radar	4-6
4.3	Vertical-Plane Coverage	4-6
4.4	Conclusions and Recommendations	4-8

Chapter 5 – Cognitive Techniques **5-1**

5.1	Introduction	5-1
5.2	Cognition	5-1
5.3	Conclusions and Recommendations	5-5

Chapter 6 – Regulatory Issues **6-1**

6.1	Summary	6-1
6.2	Today’s and Future Radar Spectrum Environments	6-1
6.3	Current Issues of Interference Between Wireless and Radar Systems	6-2
6.4	Sharing Studies for Coexistence of Systems in the Same Band	6-4
6.5	Sharing Studies for Coexistence of Systems in Adjacent Bands	6-4
6.6	White Space	6-5
6.7	Current Radar Regulatory Standards	6-5
6.7.1	Regulatory Standards at Worldwide Level – ITU	6-5
6.7.2	Regulatory Standards at European Level – NATO	6-6
6.7.3	Spectrum Enforcement and Legal Issues	6-6
6.7.4	Common Definitions	6-7
6.8	Spectrum Regulatory Discussions	6-8
6.8.1	Spectrum Regulatory Discussions at National Level	6-8
6.8.2	Spectrum Regulatory Discussions at Regional Level	6-8
6.8.3	Spectrum Regulatory Discussions at ITU-R Level	6-8
6.8.4	WRC 2015 Agenda Items Related to Radars	6-9

Chapter 7 – Conclusions and Recommendations **7-1**

7.1	Summary and Conclusions	7-1
7.2	Recommendations	7-1

Chapter 8 – References 8-1

Annex A – List of Meetings A-1

Annex B – Bibliography of Work/Outputs of SET-182 B-1

B.1	Book Chapters	B-1
B.2	Journals	B-1
B.3	Conferences/Workshops	B-2
B.4	Journal Special Issue	B-5
B.5	Conference Activities	B-5
B.6	Tutorials	B-5
B.7	Technical Committee	B-6
B.8	SET-204 Two-day Specialists’ Meeting on “Waveform Diversity” 29/30 September 2014, Berlin, Germany	B-6

Annex C – Summary of SET-066 Report C-1

C.1	Introduction	C-1
C.2	The Nature of the Problem	C-1
C.3	Objectives	C-2
C.4	Report Structure	C-3
C.5	Mechanisms Which Cause Interference Between Military Radar and Civil Telecommunications	C-3
C.5.1	Challenges Imposed on Radar Services	C-3
C.5.1.1	Current Environment	C-3
C.5.1.2	Future Environment	C-4
C.5.1.3	Technical Reasoning	C-5
C.5.1.4	Economic Reasoning	C-5
C.5.2	The Nature of Interference	C-6
C.5.2.1	In-Band Interference	C-8
C.5.2.2	Out-Of-Band (OOB) Interference	C-8
C.5.2.3	Spurious Band Interference	C-8
C.5.3	Features that Affect the Interference Seen in the System	C-9
C.5.3.1	Incident Field Strength	C-9
C.5.3.2	Radar Receiver Selectivity	C-9
C.5.3.3	Spurious Emission Limits of Interference Source	C-10
C.5.3.4	Presence of Spurious Pass-Bands in Victim Receiver	C-10
C.5.3.5	Radar Receiver Linearity	C-10
C.5.3.6	Interference Frequency Offset	C-10
C.5.3.7	Polarisation	C-10
C.5.3.8	Modulation or Coding Used in the Radar	C-11
C.5.3.9	Radar Receiver/Processor Mode of Operation	C-13
C.5.4	Initial Considerations of Interference Mechanisms in the Radar Receiver	C-13
C.5.4.1	Consideration of Interference-to-Noise Ratio I/N	C-13
C.5.4.2	L-Band Range Reduction Caused by Variation in I/N	C-13

C.5.4.3	Hostile Source Transmit Power Required to Cause Range Reduction	C-15
C.5.4.4	Variation in Detection Probability (P_d) Due to Variation in I/N	C-16
C.5.4.5	Receiver Blocking	C-19
C.5.4.6	Range Accuracy	C-20
C.5.4.7	Azimuth Accuracy	C-21
C.5.4.8	Effects on Other Parameters	C-25
C.5.4.9	Permanent Effects	C-26
C.5.5	Some Interference Scenarios	C-26
C.5.5.1	Scenario 1 – Interference Signals in the Frequency Domain	C-26
C.5.5.2	Scenario 2 – Interference in the Time Domain	C-29
C.6	Conclusions	C-34
C.6.1	General	C-34
C.6.2	Antennas	C-34
C.6.3	Receivers	C-35
C.6.4	Impact on Military Radars	C-35
C.6.5	Impact of UWB	C-35
C.6.6	Transmitter	C-36
C.7	Reference	C-36

List of Figures

Figure		Page
Figure 1-1	Example of Spectral Regrowth Intruding into Adjacent Bands	1-2
Figure 2-1	Spectrum of an X-Band Radar Using a Magnetron	2-1
Figure 2-2	RSEC Emissions Mask; Example Comparison with Emissions Mask	2-2
Figure 2-3	Comparison of Standard Waveforms and a Spectrally Confined Waveform	2-3
Figure 2-4	Sinc Kernel with a Chirp Interval of 100 ns and GWS Kernel Function with a Chirp Interval of 100 ns and $\sigma = 130$ ns	2-5
Figure 2-5	For a 512-Bit Pseudo-Noise Code, the Sinc Kernel with a Chirp Interval of 100 ns and GWS Kernel Function with a Chirp Interval of 100 ns and $\sigma = 130$ ns	2-6
Figure 2-6	Comparison of the Autocorrelation Functions of the GWS Kernel for $\sigma = 80$ ns and 130 ns	2-6
Figure 2-7	Hardware Implementation of Linear Spectrally Clean Waveform	2-8
Figure 2-8	Comparison of Ideal and Measured Spectra of GWS Waveform at Input to PA	2-8
Figure 2-9	Implementation of Out-Phased X-Band Transmitter	2-9
Figure 2-10	X-Band Output of Spectrally Clean Waveform Using Linear Chireix Out-Phasing System (Sum Channel) of Figure 2-9	2-9
Figure 2-11	Constant-Envelope Phase-Modulated Signal $m(t)$ Generated for Each Channel	2-10
Figure 2-12	PCFM Radar Waveform Implementation	2-14
Figure 2-13	180° Coupler LiNC Transmitter Implementation	2-15
Figure 2-14	Unwrapped Phase of Waveforms $s_1(t)$ and $s_2(t)$	2-15
Figure 2-15	LFM Spectrum with Tukey Taper and Without for a Frequency Span of 110 MHz and 10 dB/Division Vertical Scale as Captured by a Spectrum Analyser	2-17
Figure 2-16	Hardware-Optimized Spectrum with Tukey Taper and Without for a Frequency Span of 110 MHz and 10 dB/Division Vertical Scale as Captured by a Spectrum Analyser	2-17
Figure 2-17	Future Radar Transmitter Power Amplifier	2-18
Figure 2-18	Baylor Non-Linear Optimization Test Platform	2-19
Figure 2-19	The Pareto Optimum Locus for a Simulated Power Amplifier Device, Displayed with PAE and ACPR Contours	2-20
Figure 2-20	Measurement of Surrounding Values of Γ_L in the Smith Chart for PAE and ACPR Gradient Optimization	2-21
Figure 2-21	Determination of the Next Γ_L Candidate for the Cases: $ACPR > ACPR_{target}$ (Out of Compliance) and $ACPR \leq ACPR_{target}$ (in Compliance)	2-21

Figure 2-22	Simulated Load-Pull Contours for Modelithics Non-Linear Transistor Model, with the PAE Contours, ACPR Contours, and Constrained “Pareto” Optimum Shown	2-22
Figure 2-23	Skyworks Amplifier Traditionally Measured Load-Pull Results and Search Algorithm Results from Starting $\Gamma_L = 0.9/-90^\circ$	2-23
Figure 2-24	Search Vector Construction for: $S_m > 0$ (Out of Compliance) and $S_m \geq 0$ (in Compliance)	2-25
Figure 2-25	Spectral-Mask Based Search Results from Multiple Starting Γ_L Values	2-26
Figure 2-26	Measured Spectra and Spectral Mask at Starting Point $\Gamma_L = 0.9/-90^\circ$ and Search Endpoint $\Gamma_L = 0.548/-36.24^\circ$	2-27
Figure 2-27	The Smith Tube for Joint Circuit and Waveform Optimization	2-27
Figure 2-28	Conceptual Depiction of Range-Resolution Optimization Using the Smith Tube	2-28
Figure 2-29	Maximum PAE and Minimum ACPR as Measured from Load-Pull Data Taken at Multiple Bandwidth Values for a Skyworks Amplifier	2-29
Figure 2-30	Measured Load-Pull Data for Different Bandwidth Chirp Waveforms	2-30
Figure 2-31	Visualization of the Design Solution in the Smith Tube Based on Measured Data	2-31
Figure 3-1	Notional Receiver/Processor Hierarchy Diagram	3-1
Figure 3-2	Analog Receiver	3-2
Figure 3-3	LNA Distortion versus Input Power	3-3
Figure 3-4	Single Downconversion	3-4
Figure 3-5	Analog Coherent I/Q Downconverter	3-4
Figure 3-6	Digital Coherent I/Q Down Conversion	3-5
Figure 3-7	Hilbert Transform Computation of Real and Imaginary Signal Components	3-5
Figure 4-1	Schematic of Passive Bistatic Radar	4-1
Figure 4-2	The Antenna Array of the Passive Radar Demonstrator Produced by Airbus Space and Defence	4-2
Figure 4-3	OFDM: Multiplexing of the Digital Bit Stream into Multiple Parallel Streams	4-3
Figure 4-4	LTE Time Domain Frames and a Single Resource Block	4-4
Figure 4-5	Resource Grid and Spectrum of a 1.4 MHz LTE Signal	4-5
Figure 4-6	Ambiguity Function of LTE Signal of Figure 4-5: Normal Cyclic Prefix and Extended	4-6
Figure 4-7	Measured Vertical-Plane Radiation Patterns of BBC VHF FM Radio Transmitter at 98 MHz, 108 MHz and 8-Bay DVB-T Transmitter	4-7
Figure 4-8	The Effect on Detection Range of the Elevation-Plane Pattern of the Source Can Be Substantial	4-7
Figure 5-1	The Perception – Action Cycle of Cognitive Radar	5-2
Figure 5-2	Conventional Adaptive Radar; Cognitive Radar	5-2

Figure 5-3	EDA Illustration of Levels of Control of Unmanned Maritime Systems	5-3
Figure 5-4	ALFUS Framework	5-4
Figure 5-5	ALFUS Illustration	5-4
Figure 6-1	Available Spectrum for Radar Use	6-1
Figure 6-2	NEXRAD Weather Radar in Grand Rapids, Michigan, USA	6-2
Figure 6-3	Communication Systems on Tower in Broomfield, Colorado, USA	6-2
Figure C-1	Output of Pulse Compressor Matched Waveform	C-11
Figure C-2	Output of Pulse Compressor Partially Matched Waveform	C-12
Figure C-3	Effective Power at Victim Radar Receiver When Transmitted from a Hostile Interference Source	C-15
Figure C-4	Effect of Loss of Sensitivity on Radar Detections	C-19
Figure C-5	Idealised A-Scope Trace	C-20
Figure C-6	Noise Effect in Threshold Crossing	C-21
Figure C-7	Effect of the Within Beam Integrator	C-22
Figure C-8	Theoretical Angular Accuracy vs. Signal-to-Noise Ratio	C-22
Figure C-9	Monopulse Error as a Fraction of Beamwidth	C-25
Figure C-10	Broad-Band Noise-Like Interference Signal Present in Receiver Bandwidth	C-27
Figure C-11	Broad-Band Non-Noise-Like Interference Signal Present in Receiver Bandwidth	C-27
Figure C-12	Narrow-Band Interference Signal Present in Receiver Bandwidth	C-29
Figure C-13	Aperiodic, Pulsed Interference Signal Applied to a Non-Compressed Radar System	C-30
Figure C-14	Periodic, Pulsed Interference Signal Applied to a Non-Compressed Radar System	C-31
Figure C-15	Periodic, Multiple Pulsed Interference Signals Applied to a Non-Compressed Radar System	C-32
Figure C-16	Periodic, Pulsed Interference Signal Applied to a Compressed Radar System	C-33

List of Tables

Table		Page
Table 1-1	Multiple Beam Klystrons	1-3
Table 2-1	Load-Reflection Coefficient Optimization Algorithm Simulation Results	2-23
Table 2-2	Load-Reflection Coefficient Optimization Algorithm Measurement Results	2-24
Table 2-3	Measurement Comparison of Triangulation Algorithm with Previous Two-Step Algorithm	2-24
Table 2-4	Results for Spectral-Mask Based Load Impedance Optimization from Multiple Starting Load Reflection Coefficient Values	2-26
Table 5-1	Cognitive Radar Classification Scale for Specified System Element	5-5
Table C-1	Polarisation Loss Ideal	C-10
Table C-2	The Effect of Increasing Noise Floor on the Maximum Operating Range	C-14
Table C-3	I/N and the Powers Required to Maintain them with Interferer at 161 km	C-16
Table C-4	I/N and the Powers Required to Maintain them with Interferer at 1 km	C-16
Table C-5	I/N vs. S/N	C-17
Table C-6	I/N , S/N , P_d and P_{fa} (Constant P_{fa})	C-18
Table C-7	I/N , S/N , P_d and P_{fa} (Constant P_d)	C-18

List of Acronyms

3G	Third Generation
4G	Fourth Generation
ABMD	Active Ballistic Missile Defence
ACPR	Adjacent Channel Power Ratio
ADC	Analog-to-Digital Converter
ADS	Advanced Design System
AECTP	Allied Environmental Conditions and Tests Publication
ALFUS	Autonomy Levels For Unmanned Systems
AM	Amplitude Modulation
AMTD	Automatic Moving Target Detector
APAR	Active Phased Array Radar
AS4D	Unmanned Systems Committee
ATC	Air Traffic Control
ATR	Automatic Target Recognition
ATS	Automated Tuner System
AWACS	Airborne Warning And Control System
AWG	Arbitrary Waveform Generator
BAA	Broad Agency Announcement
BBC	British Broadcasting Corporation
CEN	Comité Européen de Normalisation
CEPT	Conférence Européenne des administrations des Postes et des Télécommunications
CFA	Cross-Field Amplifier
CFAR	Constant False Alarm Rate
CIO	Chief Information Officer
CITEL	Inter-American Telecommunication Commission
CLSAT	Counter Low-Signature Airborne Targets
COHO	Coherent Oscillator
COTS	Commercial-Off-The-Shelf
CPM	Continuous Phase Modulation
CSO	Collaboration Support Office (STO)
CW	Continuous Wave
DAB	Digital Audio Broadcasting
DARPA	Defense Advanced Research Projects Agency
DBF	Digital Beamforming
DESS	DoD Electromagnetic Spectrum Strategy
DFS	Dynamic Frequency Selection
DISA	Defense Information Systems Agency
DoD	Department of Defense (United States)
DPSK	Differential Phase Shift Keying
DSA	Dynamic Spectrum Access
DSP	Digital Signal Processor
DVB	Digital Video Broadcasting
DVB-T	Digital Video Broadcasting – Terrestrial
E3	Electromagnetic Environmental Effects
ECC	Electronic Communications Committee
EDA	European Defence Agency

EIRP	Effective Isotropic Radiated Power
EM	Electromagnetic
EMC	Electromagnetic Compatibility
EMI	Electromagnetic Interference
ERC	European Radiocommunications Committee
FCC	Federal Communications Commission
FIR	Finite Impulse Response
FM	Frequency Modulation
FPGA	Field-Programmable Gate Array
FRA	France
GaN	Gallium Nitride
GBR	Great Britain
GLONASS	Global Navigation Satellite System
GPS	Global Positioning System
GSM	Global System for Mobile communication
GWS	Gaussian Weighted Sinc
HF	High Frequency
HIL	Hardware-In-the-Loop
HRI	Human-Robot Interaction
I/N	Interference-to-Noise ratio
I/Q	In-phase / Quadrature phase
ICAO	International Civil Aviation Organization
IEC	International Electrotechnical Commission
IEEE	Institute of Electrical and Electronics Engineers
IET	Institution of Engineering and Technology
IF	Intermediate Frequency
IMT	International Mobile Telecommunications
ISR	Intelligence, Surveillance and Reconnaissance
ISR-CC	ISR Collection Capability
ITU	International Telecommunication Union
ITU-R	International Telecommunication Union – Radiocommunication
LAN	Local Area Network
LFM	Linear Frequency Modulation
LHCP	Left-Hand Circular Polarization
LiNC	Linear amplification using Non-linear Components
LNA	Low-Noise Amplifier
LSB	Least Significant Bit
LTE	Long-Term Evolution
MAPC	Multi-static Adaptive Pulse Compression
MBK	Multiple Beam Klystron
MEMS	Micro Electromechanical Systems
MMIC	Monolithic Microwave Integrated Circuit
MSK	Minimum Shift Keying
MTI	Moving Target Indication
NATO	North Atlantic Treaty Organization
NCTR	Non-Cooperative Target Recognition
NEXRAD	Next-Generation Radar
NIST	National Institute of Standards and Technology

NRL	Naval Research Laboratory
NTIA	National Telecommunications and Information Administration
OFDM	Orthogonal Frequency Division Multiplexing
OFDMA	Orthogonal Frequency Division Multiple Access
OOB	Out-Of-Band
OTH	Over-The-Horizon
PA	Power Amplifier
PAE	Power-Added Efficiency
PAPR	Peak-to-Average Power Ratio
PBR	Passive Bistatic Radar
PCAST	President's Council of Advisors on Science and Technology
PCFM	Polyphase-Coded FM
PCL	Passive Coherent Location
PCR	Passive Covert Radar
PM	Phase Modulation
POL	Poland
PRF	Pulse Repetition Frequency
PRI	Pulse Repetition Interval
PSK	Phase Shift Keying
PSL	Peak Sidelobe Level
QAM	Quadrature Amplitude Modulation
QPSK	Quadrature Phase Shift Keying
R&D	Research and Development
RB	Resource Block
RCS	Radar Cross-Section
RE	Resource Element
REC	Recommendation
RF	Radio Frequency
RHCP	Right-Hand Circular Polarization
RLAN	Radio Local Area Network
RNSS	Radio Navigation-Satellite Service
RSEC	Radio Spectrum Engineering Criteria
RTA	Research Technology Agency
RTG	Research Task Group
RTO	Research Technology Organisation
S/N	Signal-to-Noise ratio
SAE	Society of Automotive Engineers
SAR	Synthetic Aperture Radar
SAW	Surface Acoustic Wave
SE	Spurious Emission
SET	Sensors and Electronics Technology (Panel)
SNR	Signal-to-Noise Ratio
SSPARC	Shared Spectrum Access for Radar and Communications
STAN	Space-Time Adaptive Nulling
STANAG	Standardisation Agreement
STAP	Space-Time Adaptive Processing
T/R	Transmit/Receive
TRL	Technology Readiness Level

TV	Television
TWT	Travelling Wave Tube
UHF	Ultra-High Frequency
UMS	Unmanned Maritime System
U.S./USA	United States of America
UWB	Ultra-Wide Band
VHF	Very-High Frequency
VSWR	Voltage Standing Wave Ratio
WAIC	Wireless Avionics Intra-Communications
WBI	Within-Beam Integrator
WCDMA	Wideband Code Division Multiple Access
WiMAX	Worldwide interoperability for Microwave Access
WRC	World Radio Conference

SET-182 Membership List

Name	Nation	Organization	Email
Hugh GRIFFITHS (Co-chair)	GBR	University College London Gower Street London WC1E 6BT UNITED KINGDOM	h.griffiths@ucl.ac.uk
Larry COHEN (Co-chair)	USA	Naval Research Laboratory Code 5300 4555 Overlook Avenue SW Washington, DC 20375 UNITED STATES	lawrence.cohen@nrl.navy.mil
Idar Andreas ANDERSEN	NOR	Forsvarets forskningsinstitutt Instituttveien 20 NO-2027 Kjeller NORWAY	idar.norheim-nass@ffi.no
Charles BAYLIS	USA	Baylor University One Bear Place #97356 Waco, TX 76798-7356 UNITED STATES	charles_baylis@baylor.edu
Shannon BLUNT	USA	University of Kansas Radar Systems & Remote Sensing Lab (RSL) Electrical Engineering & Computer Science Dept. University of Kansas Lawrence, KS 66045 UNITED STATES	sdblunt@itrc.ku.edu
David CROUSE	USA	Naval Research Laboratory Code 5300 4555 Overlook Avenue SW Washington, DC 20375 UNITED STATES	david.crouse@nrl.navy.mil
Ulku DOYURAN	TUR	ASELSAN Inc. Systems Eng. Dept. of Radar Systems ASELSAN Inc. Radar, EW and Intelligence Systems Div P.O. Box 1 ASELSAN A.S. REHIS-SMD/RADAR-SMM Mehmet Akif Ersoy Mah. 296 Cad No: 16 Yenimahalle 06172 Ankara	udoyuran@aselsan.com.tr

Name	Nation	Organization	Email
Olivier FORGEOT	FRA	THALES AIR SYSTEMS Voie Pierre Gilles de Gennes F-91470 Limours FRANCE	olivier.forgeot@thalesgroup.com
Tom HIGGINS	USA	Naval Research Laboratory Code 5300 4555 Overlook Avenue SW Washington, DC 20375 UNITED STATES	thomas.higgins@nrl.navy.mil
Eric MOKOLE	USA	Retired; Formerly with Naval Research Laboratory Code 5300 4555 Overlook Avenue SW Washington, DC 20375 UNITED STATES	eric.mokole@outlook.com
Myriam NOUVEL	FRA	THALES AIR SYSTEMS Voie Pierre Gilles de Gennes F-91470 Limours FRANCE	myriam.nouvel@fr.thalesgroup.com
Tomasz RUTKOWSKI	POL	PIT-RADWAR S.A. ul. Hallera 233A 80-502 Gdańsk POLAND	tomasz.rutkowski@pitradwar.com
Sarah SEGUIN	USA	University of Kansas Electrical Engr. & Comp. Sci. Dept. 1520 W. 15th Street Lawrence, KS 66045 UNITED STATES	seguin@ku.edu
Nicolas SENTENAC	FRA	THALES Systèmes Aéroportées 2, Av Gay-Lussac F-78851 Elancourt FRANCE	nicolas.sentenac@fr.thalesgroup.com
Aaron SHACKELFORD	USA	Naval Research Laboratory Code 5300 4555 Overlook Avenue SW Washington, DC 20375 UNITED STATES	aaron.shackelford@nrl.navy.mil
Firat TIGREK	TUR	ASELSAN P.O. Box 1 06172 Yenimahalle Ankara TURKEY	rftigrek@aselsan.com.tr

Radar Spectrum Engineering and Management

(STO-TR-SET-182)

Executive Summary

The Radio-Frequency (RF) electromagnetic spectrum, extending from below 1 MHz to above 100 GHz, represents a precious resource. It is used for a wide range of purposes, including communications, radio and television broadcasting, radio navigation, and sensing. Radar represents a fundamentally important use of the Electromagnetic (EM) spectrum, in applications which include air traffic control, geophysical monitoring of Earth resources from space, automotive safety, severe weather tracking, and surveillance for defence and security. Nearly all services have a need for greater bandwidth, which means that there will be ever-greater competition for this finite resource. The objective of this Task Group has been to develop experiments and models that exploit transmitter, receiver, and waveform designs toward more optimal spectrum use.

Cognitive radar represents a potentially very significant set of techniques in spectrum engineering. Some would argue that there is much to be gained from a scheme which intelligently allocates spectrum occupancy as a function of all of these variables. However, a clear and universally-agreed definition of cognitive radar, and an understanding of its potential military benefits, does not yet exist.

As well as technical approaches to spectrum engineering, the regulatory issues need to be considered. There is a pressing need for a more intelligent approach to regulation, in which the degree of interference of one kind of signal with another is understood in a quantitative manner, via models which are supported by experimental measurements, and the regulations framed accordingly.

General research areas that need to be addressed in subsequent SET activities include:

- 1) The design of efficient power amplifiers to provide improved spectral purity;
- 2) Adaptable transmit filters and antenna technology for active arrays that more completely integrate EM theory and signal processing;
- 3) Adaptive/cognitive waveform design for spatial/spectral interference avoidance on transmit;
- 4) Optimization of radar emissions accounting for non-ideal/non-linear aspects of the transmitter;
- 5) Development of radar emission structures that induce minimal interference to commercial users in adjacent spectral bands; and
- 6) Innovative receiver designs supporting digital signal processing for in-band reception and adjacent-band interference rejection.

Furthermore, the SET-182 team strongly recommends the following:

- Communication and military governing bodies need to ensure more collaboration.
- NATO Nations should identify and allocate significant funding for spectrum R&D.
- NATO governing organizations for radar and military should take a greater role in helping the wireless community develop systems and standards that are robust to radar emissions.
- Acquisition program managers for military systems must have greater involvement in radar spectrum management. If collaboration and interaction is to become a reality, their heavy involvement is a necessity.

- The wireless community and the policy makers need a better understanding of radar requirements and how the operation of wireless can adversely affect radar.

Finally, the RTG has built upon the work of the SET-066 Task Group on “Frequency Sharing Between Communication and Radar Systems”, whose report was not ultimately published; however, a short summary of that report is provided as Annex C to this report.

Ingénierie et gestion du spectre radar

(STO-TR-SET-182)

Synthèse

Le spectre électromagnétique des radiofréquences (RF), compris entre moins de 1 MHz et plus de 100 GHz, est une ressource précieuse, employée à de très nombreuses fins, notamment les communications, la diffusion radio et télévisuelle, la radionavigation et la détection. Le radar représente un usage capital du spectre électromagnétique (EM), dans des applications qui incluent le contrôle de la circulation aérienne, le suivi géophysique des ressources terrestres depuis l'espace, la sécurité automobile, le suivi des phénomènes météorologiques violents et la surveillance en vue de la défense et de la sécurité. Presque tous les services ont besoin d'une bande passante plus large, ce qui signifie que la compétition ira croissant pour cette ressource finie. L'objectif de ce groupe de travail était d'élaborer des expériences et des modèles exploitant la conception des émetteurs, récepteurs et formes d'ondes de manière à optimiser l'utilisation du spectre.

Le radar cognitif constitue un ensemble potentiellement très important de techniques d'ingénierie du spectre. Certains assurent qu'il y a beaucoup à gagner à un programme qui attribue intelligemment l'occupation spectrale en fonction de toutes ces variables. Cependant, il n'existe pas encore de définition claire et universellement acceptée du radar cognitif, ni de ses avantages militaires potentiels.

Outre les approches techniques de l'ingénierie du spectre, les questions réglementaires doivent également être considérées. Il est urgent de disposer d'une approche plus intelligente de la régulation, qui envisage de manière quantitative le niveau d'interférence d'un type de signal avec un autre, au moyen de modèles étayés par des mesures expérimentales.

Les domaines de recherche générale qui doivent être traités dans les activités ultérieures du SET sont les suivants :

- 1) Conception d'amplificateurs de puissance efficaces pour améliorer la pureté spectrale ;
- 2) Filtres d'émission adaptables et technologie d'antenne en vue de réseaux actifs intégrant plus complètement la théorie EM et le traitement des signaux ;
- 3) Conception d'une forme d'onde adaptative / cognitive pour éviter les interférences spatiales / spectrales avec l'émission ;
- 4) Optimisation des émissions radar pour prendre en compte les aspects non idéaux / non linéaires de l'émetteur ;
- 5) Développement de structures d'émission radar qui induisent une interférence minimale avec les usagers commerciaux des bandes spectrales adjacentes ; et
- 6) Conceptions innovantes de récepteurs prenant en charge le traitement du signal numérique pour la réception dans la bande et le rejet des bruits des bandes adjacentes.

En outre, l'équipe du SET-182 recommande fortement ce qui suit :

- Plus de collaboration entre les instances dirigeantes des communications et des armées.
- L'affectation de plus de ressources financières au profit de la recherche et du développement relatifs à la gestion du spectre des fréquences par les pays de l'OTAN.

- Les organisations de gouvernance de l'OTAN pour les radars et les communications militaires devraient aider davantage la communauté du sans fil à élaborer des systèmes et des normes adaptés aux émissions radar.
- Les responsables des programmes d'acquisition pour les systèmes militaires doivent s'impliquer davantage dans la gestion du spectre radar si l'on veut que la collaboration et l'interaction deviennent une réalité.
- La communauté sans fil et les décideurs ont besoin de mieux comprendre les exigences des radars et la manière dont le fonctionnement du sans fil peut nuire aux radars.

Enfin, le RTG s'est appuyé sur les travaux du SET-066 relatif au « Partage des fréquences entre les systèmes de communication et les systèmes radar », dont le rapport n'a finalement pas été publié. Un court résumé de ce rapport est cependant inséré ici en tant qu'annexe C.

Chapter 1 – INTRODUCTION

1.1 CONTEXT

The physics of Electromagnetic (EM) propagation, along with the vast operational differences between the various spectrum users, clearly makes the commoditization of spectrum usage very problematic. Different frequency bands experience different amounts of atmospheric attenuation, reflection, refraction, and penetration within the various levels of the troposphere and ionosphere, both of which significantly impact propagation depending on the operating frequency. All spectrum users share a common fundamental payload: information – be it for dissemination (communications), self-referential via comparison of different emissions (navigation), or extracted from the environment itself (radar). However, the nature and source of the information are radically different for each modality, thereby necessitating significantly different operational paradigms.

Modalities such as communications involve one-way propagation to convey information from one location to another, with the transmit power and receiver sensitivity being largely driven by the separation distance and the amount of atmospheric attenuation. In contrast, sensing modalities like radar involve two-way propagation such that, for the same separation distance as the communication link, a radar would require orders-of-magnitude greater transmit power and receiver sensitivity just to contend with EM wave attenuation and system losses. Of even greater importance, the information the radar seeks represents aspects of the illuminated environment that can be used to discriminate the signatures of potential targets of interest from among an overwhelming collection of reflected echoes (akin to listening for a whisper in a hurricane). Furthermore, while different measures may be taken to ensure the quality of information obtained at the communication receiver (interleaving, forward error correction coding, channel equalization, etc.), the information the radar seeks may conversely be non-cooperative (for example, stealthy targets).

Despite the rather incompatible aspects of these modalities, economic forces dictate that radar systems must become more interoperable with commercial communications. To do so requires that radar:

- 1) Drastically curtail the spectral regrowth of high-power emissions into adjacent bands through the use of improved technology and operational methods; and
- 2) Contend with the steady encroachment of interference from commercial emitters into the radar bands.

While the latter is governed by the ITU internationally and by various organizations within each Nation (for example, the FCC within the USA), there is no guarantee that commercial spectrum users will actually adhere to emission specifications at all times (litigation is not an option during a combat mission). That said, the publicly available communication standards may aid in identifying the structure of an interference source so as to effect its cancellation or at least partial suppression. With regard to curtailing adjacent-band spectral regrowth of radar emissions, for obvious reasons of national security and public safety, the precise form of radar emissions cannot be made available to the commercial spectrum users with which the radar could potentially interfere. Consequently, the impetus is largely on the radar to remediate the interference it may cause to other spectral occupants. This solution could potentially take the form of spectral avoidance (frequency hopping), spectral/spatial nulling on transmit, modifications to transmit hardware, multi-static networked operation, or some combination thereof.

Currently, the spectrum from 2 – 4 GHz, known as S-band in the radar community, is being highly contested as the commercial communication industry continues to apply intense pressure on governments to allow 4G systems like WiMAX and LTE to operate in bands allocated for radar. For example, U.S. President Obama's National Broadband Plan [68] delineates the process by which any reallocation of this spectrum may be determined, while the recent PCAST recommendation suggests the expansion of spectrum sharing [82].

The S-band regime is attractive from a radar standpoint because it provides a trade-off between long-distance search/track capabilities (usable propagation distance improves as frequency decreases due to less attenuation) and reasonable antenna size (antenna aperture size decreases as frequency increases). While this band is also attractive to the wireless industry for many of the same reasons, it must be acknowledged that most communication systems are cell-based, using relatively shorter distances (25 – 50 km radius) and do not require the significant long-range capability that radar systems need for meeting operational requirements. In 2006, it was recognized by the U.S. DoD that conflicts would arise between radar and these commercial wireless systems. To that end, the Naval Research Laboratory in 2007 conducted testing at the Surface Combat Systems Center, Wallops Island, VA, USA, where it was found that the EMI generated by a high-power S-band radar can cause severe degradation to a WiMAX network 8 miles away. While this result was to be expected, it highlights the need for R&D to address potential solutions to the growing problem of spectral congestion.

1.1.1 Adjacent-Band Interference Mitigation for Radar Emissions

Recent occurrences of EMI from the U.S. Navy’s AN/SPY-1 radar to WiMAX communication systems have demonstrated the urgency for reducing adjacent-band interference caused by out-of-band noise and spectral regrowth. Furthermore, it is expected that the forthcoming NTIA Radar Spectrum Engineering Criteria (RSEC) will dictate considerably more stringent spectral roll-off requirements than has previously been the case (may increase from the current 20 dB/decade to as much as 30 or even 40 dB/decade).

Out-of-band noise, a problem for crossed-field amplifier tubes, is caused by the random fluctuations in electron beam density of the electron cloud that spirals out from the cathode to the slow wave structure. Spectral regrowth is a result of non-linearities in the transmitter that produces spurious signals at frequencies outside the operational bandwidth. These spectrally expanded emissions can extend into adjacent bands, causing interference to other spectral occupants as depicted in Figure 1-1. Because the amplifier of a high-power radar operates in saturation, these non-linear effects can be quite pronounced. These adjacent-band emissions are further exacerbated by the fact that the power in the spectral regrowth regions is directly proportional to the peak power of the radar, which could be as high as tens of megawatts.

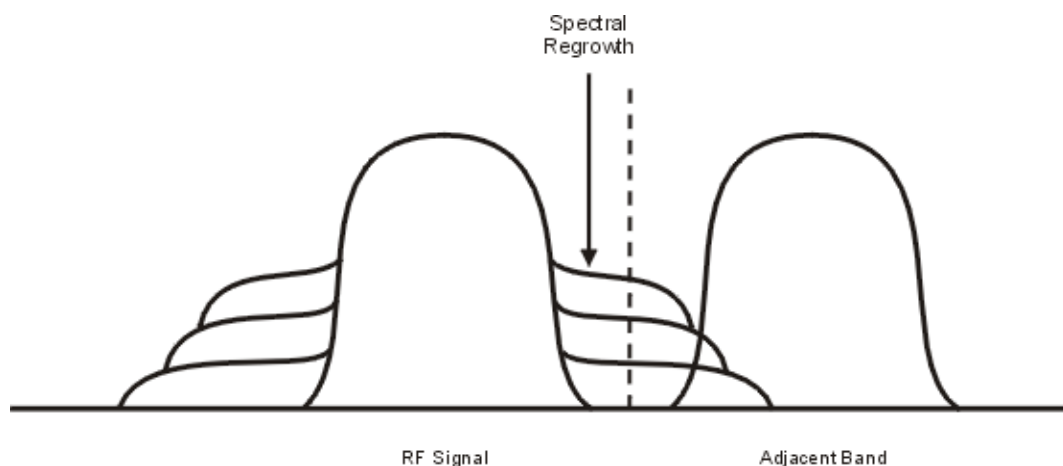

Figure 1-1: Example of Spectral Regrowth Intruding into Adjacent Bands.

While it is predominantly the non-linearity of the Power Amplifier (PA) that is the source of spectral regrowth, a holistic treatment of the entire transmitter and the waveform-modulated pulse is necessary to compensate for this effect. Given a desired waveform to be modulated onto a high-power pulse, the transmitter components preceding the PA (power supply, exciter, modulator) induce some Amplitude Modulation (AM) to AM distortion and AM to Phase Modulation (PM) distortion of the waveform,

thus compounding the subsequent spectral regrowth distortion emitted from the PA. Furthermore, the rapid switching that occurs at the rise and fall of the pulse produces significant contributions to the frequency extent of the spectral spreading. A “slowing down” of the rise and fall times, a significant technical challenge by itself for high-power operation, will produce further distortion of the intended waveform, which translates into lost sensitivity. Thus it is necessary that all physical components and the intended waveform be made to operate in a coordinated manner to mitigate spectral regrowth while maintaining acceptable radar performance. This coordination will require new transmitter components and architectures and a much greater interaction between transmitter design and waveform design, so as ultimately to enable the requisite precise tailoring of physical radar emissions. A current collaborative effort between the NRL Radar Division and Baylor University has demonstrated that it is possible to maximize Power Added Efficiency (PAE) in a GaN PA while simultaneously reducing interference to adjoining channels.

The use of microwave-tube PAs in high-power radar transmitters will be a reality for at least the next 25 years. For example, numerous U.S. radars like the Navy’s AN/SPY-1 and the Air Force’s AWACS employ Crossed-Field Amplifiers (CFAs) and klystrons, respectively, with CFAs generating high levels of out-of-band noise induced by AM-to-AM and AM-to-PM effects. High-efficiency PAs remain inherently non-linear; the reduction of these AM-to-AM and AM-to-PM effects provides part of the solution to mitigating adjacent-band interference. Recent work that may overcome the unwanted spurious emissions of current high-power radar sources involves Multiple Beam Klystrons (MBKs). Research groups in industry and government laboratories have designed and demonstrated MBKs with 6-8 beams at L-band (1.3 GHz) and S-band (3.26 GHz). These MBKs enable duty cycles that could double the average power of existing radar transmitters while reducing spurious emissions by as much as 30 dB [74], [2], [22], [73].

Table 1-1: Multiple Beam Klystrons.

Organization	Frequency [GHz]	Peak Output Power [MW]	Gain [dB]	Efficiency [%]	# Beams	Bandwidth [MHz]
NRL	3.26	600	25	40	8	192
Thales	1.30	1020	48	65	7	> 10
CPI	1.30	8100	48	53	6	> 5
Toshiba	1.30	10200	49	66	6	3

Also at the component level, the use of adaptive RF filter technology may provide a means to attenuate the spurious emissions generated by the PA. With the infusion of advanced active-array radar technology, adaptive filters could prove critical in attenuating out-of-band emissions, particularly in radars that frequency hop. For radar, the primary technological hurdle for the post-PA filter approach is to minimize the insertion loss of the filter, as this loss of transmit power translates directly into a sensitivity loss.

Beyond the impact of individual components, the overall transmitter topology can also be exploited to reduce spurious emissions. Such methods to diminish adjacent-band interference have their genesis in the 1930s, when they were directed at contending with the effects from vacuum-tube PAs in high-power AM broadcast transmitters. The Chireix [23] and Doherty [30] PA configurations are classical techniques developed during this time. This general class of transmitter topologies is broadly categorized as Linear amplification with Non-linear Components (LiNC) [26], [11]. Recently, the growth of 4G wireless technology that relies on amplitude and phase modulations to encode information (64 QAM is quite common) has generated a resurgence of interest and research into mitigation techniques for spectral regrowth in PAs, for both wireless and radar. The primary driver of this research has been the need to contend with the large Peak-to-Average Power Ratio (PAPR) that occurs for Orthogonal Frequency Division Multiple Access (OFDMA) waveforms, the basis for WiMAX and LTE 4G communication systems [50]. While these efforts in the communications

community may be leveraged to some degree, the distinct requirements of radar (pulsed operation, wide instantaneous bandwidth, very high transmit power, constant envelope or nearly so) necessitate investigation into radar-specific PA topologies.

As part of a long-term effort to address radar spectrum issues, the NRL Radar Division has conducted exploratory research into developing spectrally confined transmitted waveforms and using the Chireix technique to implement such waveforms for radar [34], [35], [29]. If the constant-envelope requirement is relaxed, thus allowing AM effects, the result is sufficient waveform design freedom with which to effect a physical emission with excellent spectral containment. By converting amplitude excursions into two separate phase excursions, a pair of high-efficiency PAs can be employed in parallel, thus maintaining high-power operation while achieving some cancellation of out-of-band spurious products. Preliminary research indicates that other methods, such as envelope tracking and 180° coupling, may offer attractive alternative techniques for reducing spurious emissions while maintaining high efficiency. The fundamental capability of high-power AM emissions can be exploited to drive further research on unified transmitter/waveform design, with a goal of realizing spectral containment with a constraint of minimal amplitude variation (loss) and potentially may even lead to means with which to control the spectral spreading caused by a radar pulse's rise and fall times.

Prof. Zoya Popovic of the University of Colorado has conducted extensive research on envelope tracking in PAs [56], [84] for reducing out-of-band spectral regrowth. Envelope tracking establishes linearity in a PA by supplying just enough power supply voltage, which is proportional to the input voltage level, such that the amplifier is not allowed to go into saturation. A recent innovation developed by Prof. Charles Baylis of Baylor University shows how the spectral characteristics of the PA output can be assessed using a technique from Wirtinger Calculus [7], [8]. This technique assumes a discrete portion or operating point of a transistor's large-signal voltage/current curve and computes the Fourier coefficients for that operating point, which can then provide the magnitude and phase information ascribed to those signal components generated at that operating point. The importance of this formulation is that by appropriately parameterizing the PA operation the performance can be optimized, thus streamlining the PA design process. In addition, Prof. Baylis has demonstrated that it is possible to maximize Power Added Efficiency (PAE) in a PA while simultaneously minimizing the Adjacent Channel Power Ratio (ACPR) through a group of optimization routines that determine the best fit or combination of desired PAE and ACPR. While earlier research by NRL that attempted to optimize the waveforms and PA circuitry independently yielded reduced out-of-band spectral spreading [34], [35], [29], it is believed that joint optimization of the physical transmitter and driving waveform may be realized with even greater performance.

Another important aspect for mitigating the adjacent-band interference induced by radar emissions is the determination of appropriate radar waveforms. It is well known that the non-linear aspects of the transmitter distort radar waveforms, resulting in sensitivity loss from increased range sidelobes. As different component technologies and transmitter topologies are developed, the resulting impact on radar emissions must be considered. While a designer might concentrate on reducing out-of-band emissions, great care must be taken not to do so at the cost of sensing performance. Therefore, it is imperative that waveform design be performed jointly with transmitter and antenna design. To optimize system performance while reducing various types of interference, both to and from the radar, a holistic system design approach must be employed. Any good approach must accommodate both objectives when the system is designed, starting from signal generation to signal radiation. Prof. Shannon Blunt's group at the University of Kansas has explored new forms of waveform implementation that enable optimization of a waveform while accounting for the impact of the transmitter (that is, transmitter-in-the-loop optimization [64], [24]). Preliminary results demonstrate how the increase in range sidelobe level can be countermanded by designing waveforms that are essentially "tuned" to the specific transmitter hardware. Such approaches become particularly important if the amplitude envelope of a pulse is modified to minimize the spectral spreading induced by rapid rise and fall times. Furthermore, some organizations have focused on going beyond the usual approach of designing antennas as an add-on component, to integrating the antenna into the sub-systems behind the aperture,

thereby gaining increased control of the parameters that affect radiated system performance. This holistic approach allows the antenna, an absolutely crucial part of a radar system, to be an active component that has the spatial, spectral, and temporal characteristics that can reduce system interference.

The task of mitigating adjacent-band interference caused by radar emissions has three aspects:

- Development of spectrally cognizant device technology;
- Transmitter topology design; and
- Hardware-in-the-loop waveform design.

The following three areas are suggested avenues for reducing adjacent-band interference.

- **Transmitter Device Design/Evaluation:** This research effort should investigate the upgrade of legacy radars via:
 - 1) Replacement of the existing CFA tubes in the legacy radar transmitters with MBK tubes; and
 - 2) The impact of adaptable RF filters.Examination of all associated hardware modifications supporting PA operation, such as power supplies and pulse modulators, are a requisite part of such efforts.
- **Transmitter Topology Design/Evaluation:** This research effort should explore the efficacy of PA topologies to suppress the spurious emissions induced by non-linearities in high-power PAs. These topologies include Chireix, Doherty, 180° coupling, as well as more recent configurations. Also to be explored are methods to parameterize the non-linearities of transmitter topologies so as to enable optimization, potentially in concert with the desired waveform. A second area of focus should be the incorporation of the antenna's characteristics into the transmitter as another design parameter, such that the combination of the power amplifier with the antenna feed and radiating structure yield optimal performance.
- **Spectrally Efficient Emission Design:** This research effort should be performed in conjunction with the component and topology investigations to coordinate the final emission to be launched from a radar, so that it meets the prescribed national and international spectral masks and achieves the required sensitivity. Recent advances in hardware-in-the-loop emission design using the Continuous Phase Modulation (CPM) implementation may be leveraged to optimize waveforms specific to various transmitter configurations.

1.1.2 Adaptive/Cognitive Emission Control

While mitigation of adjacent-band interference will ensure radar compliance with standards for spectral masks and thus substantially reduce the interference that a radar may cause to other spectral occupants, there may still be occurrences of interference if a radar is forced to share spectrum with other users. Because these occurrences are situation dependent, the impetus is on the radar to be “smart” about how energy is transmitted through adaptive/cognitive emission control. One may think of adaptive emission control as being *reactive* to a situation while cognitive emission control is *proactive*. Both approaches are based on learning paradigms and really only differ conceptually in terms of the timing (*a posteriori* versus *a priori*) of transmitter interference suppression.

The details of the myriad different learning paradigms notwithstanding, the key steps to transmitter-oriented interference suppression are:

- 1) Identification of another spectral occupant for which interference is occurring (or will occur); and
- 2) The modification of the radar emission so as to suppress the energy in the given spatial direction and/or frequency band.

Of course, it is necessary to accomplish suppression of transmitter-induced interference without degrading the sensing performance of the radar or at least by keeping the degradation within an acceptable level.

Recent preliminary work at NRL, led by Dr. Aaron Shackelford [42], has explored the capability of achieving Space-Time Adaptive Nulled (STAN) radar emissions that allow interference suppression on transmit simultaneously in frequency and spatial angle. The benefit of such an approach over simply performing spatial nulling or frequency nulling separately is that it minimizes where (in frequency and space) the radar cannot look, thereby reducing the impact on sensing effectiveness. Open research questions remain, however, including how to determine the proper space-time locations of nulls, how best to predict null drift due to relative motion, and the impact of array mutual coupling and calibration on spatial null accuracy.

At the other extreme from STAN, one may also investigate how sensing can be performed using spectrally fragmented emissions [103], in which the radar is only allowed to operate in multiple disjoint bands that would not otherwise be sufficient in terms of radar performance if taken individually. It is interesting to note that the 4G wireless standard, Long-Term Evolution (LTE), employs what is referred to as *carrier aggregation* [67], whereby carriers in disjoint frequency bands can be simultaneously emitted from the same transmitter [95]. The fundamental requirement of such an approach is that inaccessible bands, particularly those in between bands being employed by the transmitter, do not encounter increased interference. The difficulty of this requirement lies in the fact that nulls are intrinsically narrow (such as employed by STAN above), while the need here is to suppress potentially broad swaths of spectrum during transmission. Given the resources to be applied by commercial interests to solve this problem, it bears investigation on how radar may be able to leverage the resulting technology as well.

1.1.3 Electromagnetic Compatibility (EMC)

While interference from a radar to external entities is of great concern, particularly when it impacts commercial users, it is every bit as important for a radar to reduce interference to/from other NATO military assets, particularly those operating on the same platform, a problem also known as co-site interference. For example, it is not uncommon that near-field EM coupling between different resources, even those operating in different frequency bands (for example, radar and satellite communication), can seriously degrade the performance of the other resource [90], [91], [104].

Specific aspects of EMC include the remediation of near-field coupling effects between proximate assets on the same platform [71], [72], the implications of antenna mutual coupling and element patterns to radar emission design (including the spectral filtering effect that has been observed as a function of transmit spatial angle [25]), and the RF fratricide that can occur from ionospheric ducting. Thus as part of any overall effort for good spectral harmony, a special emphasis must be placed on accurately modeling EMI and the unintended emissions and/or coupling that can occur. The anticipated results will be better and more accurate theoretical predictions and modifications to the transmit/receive hardware and signal processing to account for these neglected sources of interference.

1.1.4 Receiver Interference Rejection

Recent work by the NRL Radar Division [13] has also shown that the radar range domain may be an untapped resource for interference cancellation by exploiting the structure of the radar emission by Multi-static Adaptive Pulse Compression (MAPC). Both simulation and experimental results have shown that the echoes from two radars occupying the same spectrum can be separated at a common receiver via MAPC adaptive processing. In fact, multi-static interference was demonstrated to be reduced by more than 25 dB [92]. This new domain within which to perform adaptive processing raises the possibility of achieving greater selectivity between interfering radars (for example, from ionospheric ducting) as well as has the potential for new ways to combat neutral interference from commercial spectrum occupants.

Another worthy research area is exploitation of multi-dimensional modeling. The well-known STAP formulation relies on coupling of space and time (Doppler) to increase multiplicatively the adaptive degrees of freedom for interference cancellation [98]. It is this coupling increase that makes the low-rank clutter assumption feasible (relative to the now high degrees of freedom). By incorporating new forms of fast-time (range) domain interference cancellation into a multi-dimensional framework, there is the potential to acquire the enhancements necessary to contend with the growing spectrum congestion problem.

1.2 OBJECTIVES

The objective of this Task Group has been to develop experiments and models that exploit transmitter, receiver, and waveform designs toward more optimal spectrum use. In particular, power-amplifier linearization techniques and more spectrally cooperative waveforms that support radar transmitter emissions with lower spectral sidelobes have been investigated, and some novel results obtained and reported.

1.3 STUDY ORGANIZATION

The RTG has built upon the work of the SET-066 Task Group on “Frequency Sharing between Communication and Radar Systems”, whose report was not ultimately published; however, a short summary of that report is provided as Annex C of this report.

This RTG has operated since 2011, meeting biannually, and working in parallel with the SET-179 RTG on “Dynamic Waveform Diversity and Design”. Many of the members of SET-182 are also members of SET-179. This synergy has allowed us to arrange several Special Sessions and Tutorials at International Radar Conferences as well as a Special Issue of the international research journal *IET Radar, Sonar and Navigation*.

A research agenda was developed and agreed at the initial meetings, with participants reporting on progress at subsequent meetings of the RTG and assembling the sections of this report.

1.4 REPORT STRUCTURE

The structure of this report essentially follows the research agenda. Chapter 2 is concerned with techniques for generating and radiating radar waveforms of improved spectral purity, recognising that although modern digital waveform generation techniques allow precise, wide-bandwidth waveforms to be generated, it is necessary also to consider the effect of distortion introduced by the power amplifier. After all, the classical tool for radar waveform design – the ambiguity function [101] says nothing about the spectral characteristics of the signal. This leads to the novel concept of the Smith Tube, in which the impedance presented to the power amplifier device is varied dynamically through the duration of the transmitted pulse, in order to optimise the cleanliness of the transmitted spectrum. Chapter 3 provides a brief review of modern receiver design techniques, emphasising the importance of high dynamic range.

Chapter 4 considers Passive Bistatic Radar (PBR). These techniques have been studied for more than thirty years, but it is only recently that they have attained significant maturity, due to greater interest and investment from industry, the increased prevalence of digital illuminators, and applicability to real-world problems, of which spectrum congestion is one. We introduce the concept of Commensal radar, in which the waveform of the communications or broadcast illuminator is designed so that it not only fulfils its primary purpose, but is also in some sense optimised as a radar signal.

Chapter 5 is devoted to Cognitive radar, in which the radar transmission may be adaptively and intelligently designed, in response to a changing target scene and spectral environment. It is argued that although

cognitive radar techniques have great potential, a clear and universally-agreed definition of cognitive radar does not yet exist, and one of the first priorities of any subsequent activity on this subject should be to attempt to clarify and refine these concepts and definitions.

Chapter 6 considers regulatory issues. There is a pressing need for a more intelligent approach to regulation, in which the degree of interference of one kind of signal with another is understood in a quantitative manner, via models which are supported by experimental measurements, and the regulations framed accordingly.

The conclusions and recommendations are presented in Chapter 7. There are three Annexes, of which the third is a summary of the work of the SET-066 Task Group, whose report was not ultimately published. This includes a substantial section (C5) on the mechanisms that result in interference between military radars and civil telecommunications, which was one of the key topics studied by that Task Group.

Chapter 2 – IMPROVED TRANSMITTER SPECTRAL PURITY

2.1 INTRODUCTION

Portions of the military radar spectrum are being affected by the growing needs of the wireless communication community within and across national borders and in littoral regions. For these situations, the energy contained in a radiated radar waveform must be confined to a particular bandwidth and must have sufficient isolation from other channels occupied outside this channel bandwidth – hence the compelling need for well-controlled, spectrally confined (clean) radar waveforms.

Radar transmitters (indeed, transmitters in general) are inherently spectrally dirty – in other words, there is often significant energy radiated outside of the nominal band of operation. An extreme example is shown in Figure 2-1, which depicts the measured spectrum of an X-band radar using a magnetron transmitter. While inexpensive, the magnetron suffers serious drawbacks in terms of spectral purity. A modulating pulse initiates the magnetron; as the build-up of RF energy grows from noise to a critical point, at which the magnetron begins to oscillate. These oscillations differ from pulse to pulse. The artifacts resulting from this process are rather steep asymmetrical sidebands on either side of the spectral mainlobe. These frequency sidebands can cause adjacent channel interference to other occupants of the spectrum. Bandpass filters have been employed on magnetron type transmitters as a means of reducing this out-of-band interference, though the cost of this improved spectral purity is a significant loss of effective transmitter power. Note in this example that the half power bandwidth is about 10 MHz, commensurate with a pulse length of 100 ns. However, at the level 40 dB below the peak, often used in defining spectrum occupancy, the spread of frequencies is of the order of 100 MHz.

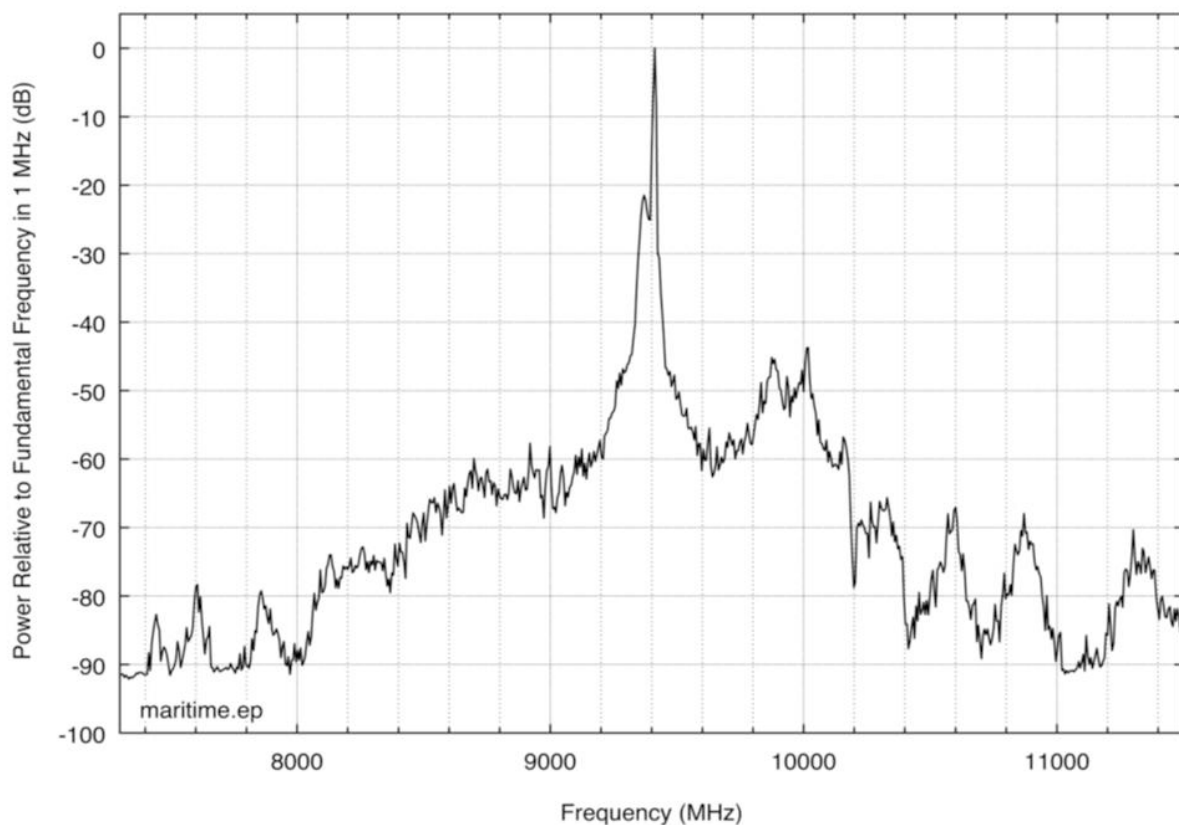

Figure 2-1: Spectrum of an X-Band Radar Using a Magnetron.

In contrast to the magnetron, all other types of radar transmitters rely on separate amplifier and waveform generation stages to enable better control of the waveform characteristics. In many modern radar systems the waveform generator is a digital synthesizer operating with very stringent frequency tolerances and extremely low levels of sideband energy. The master clock in the digital synthesiser is used to derive all timing for the radar, including the pulse repetition frequency. The digitally synthesised waveforms are converted to analog format and passed to a power amplifier, before radiation by the antenna. Commonly used radar power amplifiers based on tube technology include the klystron, Traveling Wave Tube (TWT), and Cross-Field Amplifier (CFA). Klystrons can generate Megawatts of peak power, but are limited in bandwidth due to the restrictions of their resonant cavities. For example, the Bendix AN/FPS-20 air surveillance radar, which used a klystron-based transmitter of 1950s vintage, had a peak power of 2 MW, a pulse length of 60 μ s and operated between 1.25 and 1.35 GHz. Traveling wave tubes provide peak powers of the order of 0.1 to 50 kW of peak power, and typically have much broader bandwidths than klystrons (up to two or three octaves). While on-going work is seeking to improve the spectral purity of these tube devices, the reality is that legacy systems, particularly for defence applications, will be in abundance for the next 50 years due to the long acquisition cycle for such systems and the enormous costs involved with building large modern radar systems.

Techniques which may result in cleaner transmitted spectra are therefore of great interest and importance. Specifications are developed and presented in terms of spectral masks. In the U.S. the National Telecommunications and Information Administration (NTIA) publishes a guide: “Manual of Regulations and Procedures for Federal Radio Frequency Management”, better known as the Red Book [76]. Of interest is Section 5.5, wherein the Radio Spectrum Engineering Criteria (RSEC) is defined. In the RSEC, radars are divided into five classes, A through E. This partition considers such factors as frequency coverage, peak power output, type of waveform (pulsed versus non-pulsed), and functionality (wind profiler, etc.). The RSEC determines a spectral mask based on a 40 dB bandwidth with roll-off rates that are calculated with equations according to the criteria specified in the four class designations. Figure 2-2(a) shows an example of an RSEC mask. The desired in-band radar emissions are contained within a 40 dB bandwidth shown in purple. The unwanted emissions (shown in shades of pink), composed of out-of-band and spurious emissions, are those unneeded emissions generated by non-linear operation within the radar transmitter and steep rise and fall times of the radar pulses. Figure 2-2(b) shows an example of a radar emission relative to the RSEC mask for 2 roll-off rates. The green curve has a 20 dB per decade roll-off rate and the red curve has a 30 dB per decade roll-off rate. In both cases the radar emission would be out of compliance in the upper and lower sidebands.

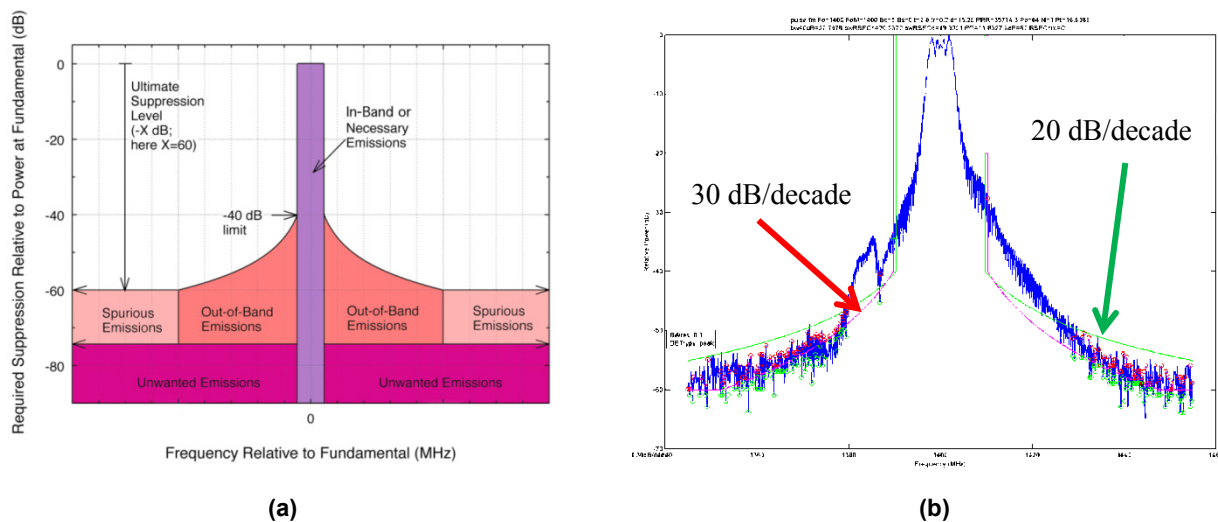

Figure 2-2: (a) RSEC Emissions Mask; (b) Example Comparison with Emissions Mask.

Various techniques to avoid interfering with users in adjacent bands by minimizing out-of-band spectral sidelobes of transmitted radar signals (feed-back and feed-forward, open-loop and closed-loop) with filters have been investigated over the past several decades [23], [58], [102], [84], [29], [64], [59], but the term *spectrally clean* waveform came into usage in the early 2000s. Consequently, the next section provides background on the early NRL work that popularized the term. Then the remainder of Chapter 2 (Sections 2.4 and 2.5) presents two particular pieces of work undertaken by members of the SET-182 TG, aimed at designing and generating spectrally cleaner waveforms and hardware.

2.2 BACKGROUND ON SPECTRAL CLEANLINESS

The terminology of spectrally clean (confined) waveforms was introduced in Ref. [21] and was further delineated in Refs. [34], [35] and [36]. In these conference papers, the authors examined a methodology that confines the spectrum of a Radio-Frequency (RF) radar waveform to the region within an instantaneous bandwidth of 20 MHz about the peak of the magnitude spectrum, so that the magnitude is at least 100 dB below the peak outside the 20 MHz band – this spectrally confined waveform was denoted *spectrally clean*. For three typical analytical representations of radar waveforms, Figure 2-3 clearly illustrates the significantly better spectral behaviour of the spectrally clean 13-bit Barker-coded waveform. This very optimistic choice of a spectrally clean research goal was somewhat arbitrary and is quite possibly unattainable with the current technology for high-power radar systems, where the 100 dB parameter is problematic for Power Amplifiers (PAs) operating in saturation as they typically do for such radars. One may expect that a realistic criterion for spectrally clean will depend on the radar application.

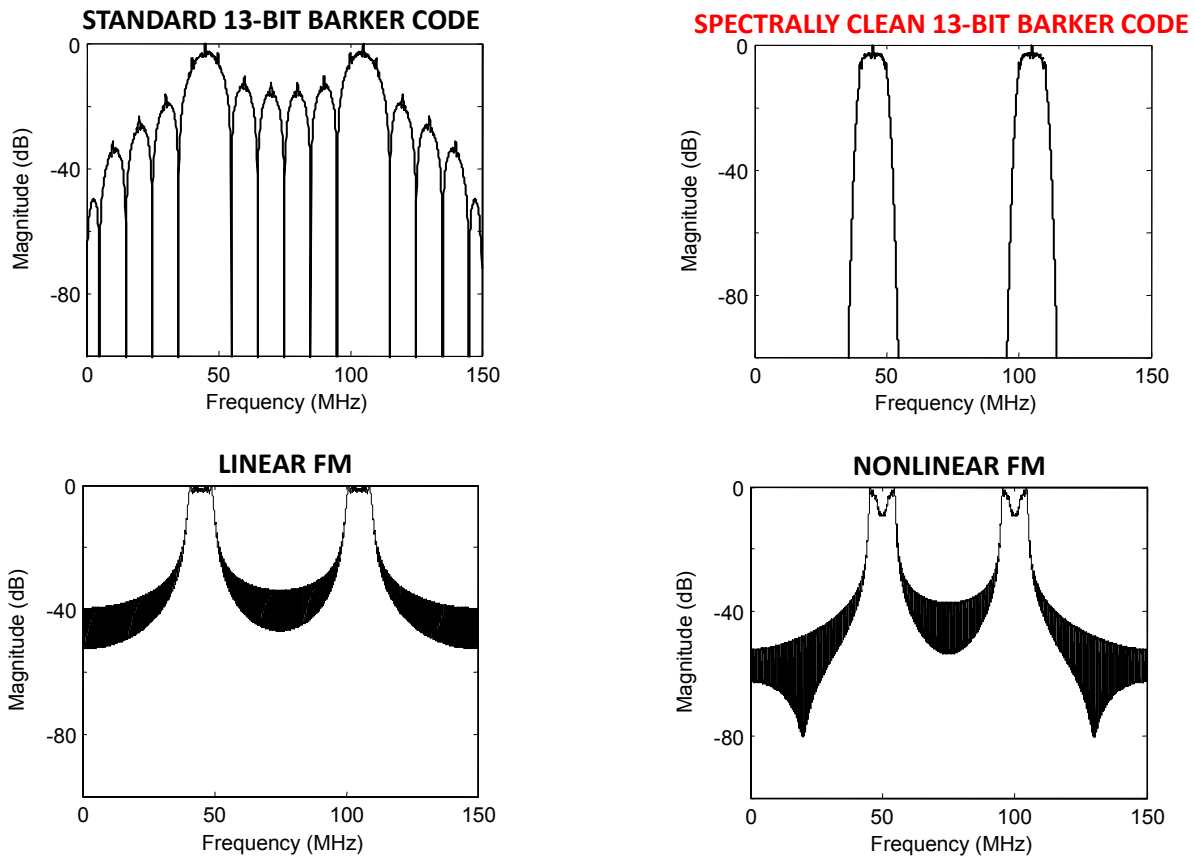

Figure 2-3: Comparison of Standard Waveforms and a Spectrally Confined Waveform.

To be considered useable, such spectrally confined waveforms additionally must maintain efficiencies that are comparable to current radar waveforms and must have sufficiently good autocorrelations to insure operationally good pulse compression in radar systems. The S&T effort of Refs. [21], [34], [35] and [36] was initiated in the Radar Division of the U.S. Naval Research Laboratory (NRL) in 2000 under programs at Technology Readiness Levels (TRLs) between 2 and 4 (according to NATO definitions) with the objective of improving the operations of naval and air-marshalling radars that were curtailed in littoral environments. Problems in littoral areas are caused by two factors:

- 1) The encroachment of mobile phone systems into navy radar bands; and
- 2) In-band interference from other radars.

Most pulsed radars utilize some form of constant-envelope pulse with phase or frequency modulation to take advantage of hardware simplicity and efficiency. However, constant-envelope waveforms cause the spectrum to broaden to several times the information bandwidth. For some cases, bandwidths exceeding 100 MHz at 100 dB down are not unusual. Because a radar typically has high peak power, interference with proximate communication networks or other in-band radars often occurs. Therefore, it is extremely important that naval platforms control the bandwidths of their radar emissions. Consequently, if both the amplitude and phase spectra of a transmitted signal are varied, a significantly narrower bandwidth (spectrally confined) might be achieved, if supportable by hardware.

The preceding discussion begs the question of how to implement a spectrally clean radar signal efficiently – a very difficult problem. The aforementioned NRL work sought efficient methods of generating waveforms that contain phase and amplitude information and approached the problem independently from two aspects:

- Design appropriate waveforms; and
- Design appropriate transmitter hardware.

The next two sub-sections briefly discuss both approaches and the work that ensued.

2.2.1 Spectrally Clean Waveform Formulation

For the sake of exposition, first consider the well-known sinc function as the bounded sampling function h . A means for achieving spectrally confined transmitted waveforms was inspired by the general cardinal series sampling expansion [55], which creates an interpolated version:

$$x_I(t) = \sum_{k=-\infty}^{\infty} x_k \text{sinc}((t - k\tau) / \tau) \tag{2-1}$$

of a transmitted signal $x(t)$ from an infinite sequence of data samples $\{x_k\}$ and a bounded sampling function. For practical applications, the cardinal series expansion was truncated in time. Specifically in radar, the finite sequences are the pulse-compression codes which are used on transmission. Thus, for a finite sequence of N samples $\{x_0, \dots, x_{N-1}\}$, the series expansion of $x(t)$ can be approximated as:

$$x_A(t) = \sum_{k=0}^{N-1} x_k \text{sinc}((t - k\tau) / \tau) = x(t) * h(t) \tag{2-2}$$

where $h(t) = \text{sinc}(t) = \sin(\pi t) / (\pi t)$, $\{x_k\}$ are equally spaced samples of $x(t)$ at intervals of the chirp interval τ , N is a fixed positive integer, and the filter function $h(t)$ is sampled at τ . The continuous function $x_A(t)$ is spectrally clean, and if allowed to continue for all time, would be a band-limited signal with bandwidth $1/\tau$. Unfortunately, $\text{sinc}(t)$ has the disadvantage of having infinite temporal support, and its leading (early time) and trailing (late time) edges can contain a significant amount of energy. From a radar transmitter standpoint,

this situation is undesirable because it requires transmit modules to remain on for a long period of time, thereby consuming a large amount of prime power. To reduce the magnitudes of the leading and trailing time-domain tails of filters, researchers have multiplied the filters by weighting functions to form a new kernel for the cardinal series that truncates the series more rapidly [34]. Not only will incorporating weight functions decrease prime-power consumption, but the self-truncating kernel can be used to control the frequency-domain and time-domain responses parametrically, a capability that is not available with the sinc filter. On the negative side, reduction of the leading and trailing edges of the time-domain input signal is achieved at the expense of increasing the bandwidth of $x_A(t)$ and vice versa.

In particular, to achieve significantly reduced leading and trailing edges, decreased on-time, and time-sidelobe properties (autocorrelations) that are comparable to the data sequence, the Gaussian Weighted Sinc (GWS) function was used instead of the sinc kernel to obtain the spectrally clean signal:

$$x_{SC}(t) = \sum_{k=0}^{N-1} x_k W(t - k\tau) \text{sinc}((t - k\tau) / \tau) \tag{2-3}$$

where $W(t) = \exp[-t^2 / (2\sigma^2)]$ and σ is a parameter that controls the bandwidth and time-domain length of $x_{SC}(t)$. As shown in Figure 2-4 for $\tau = 100$ ns and $\sigma = 130$ ns, the GWS function significantly reduces the temporal edges compared to the sinc kernel, which also decreases the required on-time – thereby reducing the efficiency of a transmit-receive module.

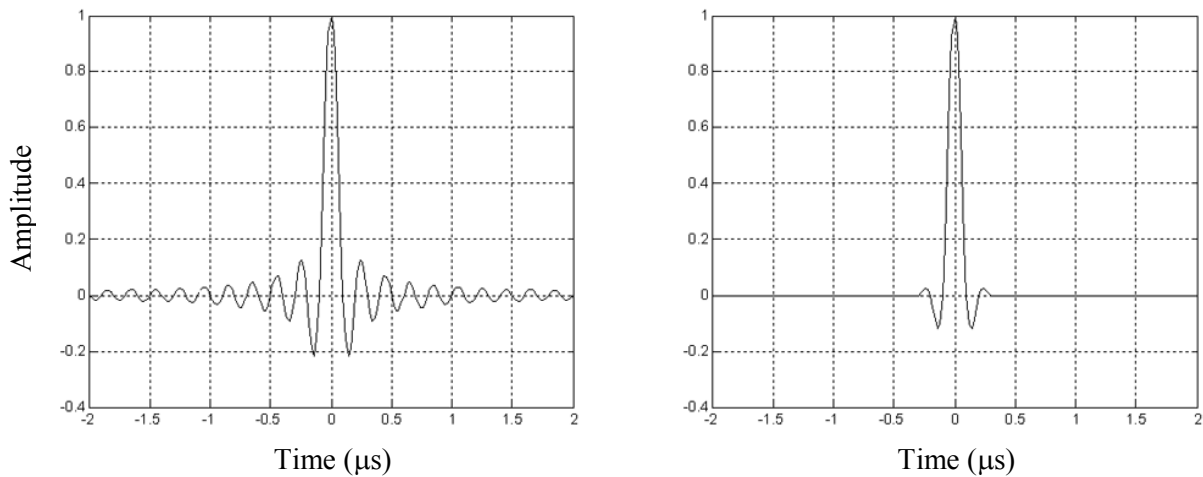

Figure 2-4: Sinc Kernel with a Chirp Interval of 100 ns (Left) and GWS Kernel Function with a Chirp Interval of 100 ns and $\sigma = 130$ ns (Right).

Although the spectrum of the GWS waveform is spectrally clean, the spectrum of the sinc kernel does not meet this requirement since the waveform is truncated at early times (spectral plots are not shown). If the sinc signal in Figure 2-5 was allowed to continue for a longer time, it would eventually meet the spectrally clean requirements at the expense of much greater energy consumption. This example demonstrates the importance of reducing the magnitude of the leading and trailing edges of the sinc kernel for efficient energy management.

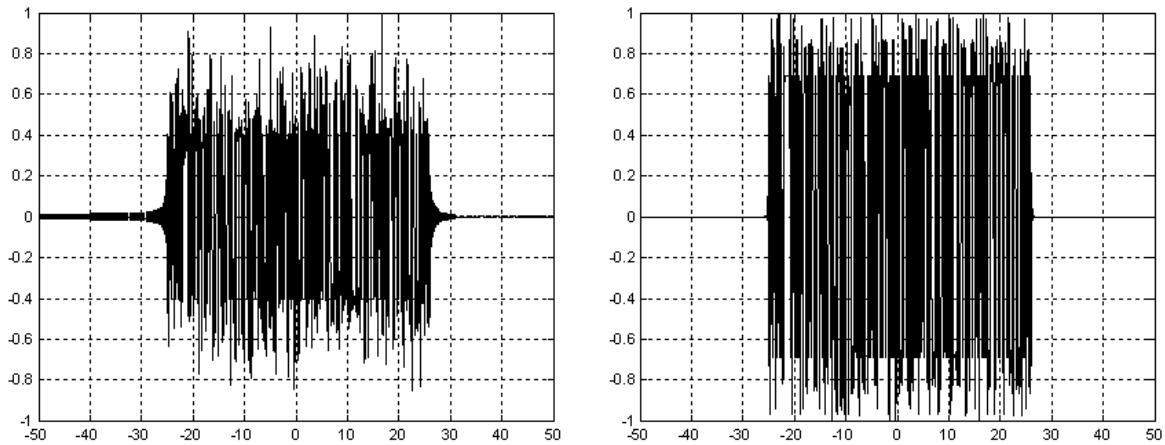

Figure 2-5: For a 512-Bit Pseudo-Noise Code, the Sinc Kernel with a Chirp Interval of 100 ns (Left) and GWS Kernel Function with a Chirp Interval of 100 ns and $\sigma = 130$ ns (Right).

To assess the impact of bandwidth and signal duration, autocorrelation functions of the GWS kernel for several values of the chirp interval σ were analyzed, but only curves for $\sigma = 80$ ns and 130 ns are plotted in Figure 2-6 to illustrate the effects. Observe that while the high near-in sidelobes are reduced as σ decreases, the -100 dBc bandwidth is increased. Thus the GWS kernel with the lower time sidelobe ($\sigma = 80$ ns) has a lower near-in time sidelobe than the GWS kernel for $\sigma = 130$ ns. It is especially important that the first time sidelobe be as low as possible to minimize its effect on the spectrally clean autocorrelation function. Although many kernels may satisfy the spectrally clean requirement, the spectrally clean autocorrelation function may be poor if the kernel autocorrelation function is poor. Consequently, when designing a spectrally clean waveform, one must ensure that:

- 1) The time extent of the waveform does not continue for a long time;
- 2) The bandwidth is as narrow as limitations permit; and
- 3) The time sidelobes of the near-in autocorrelation function of the kernel are as small as possible.

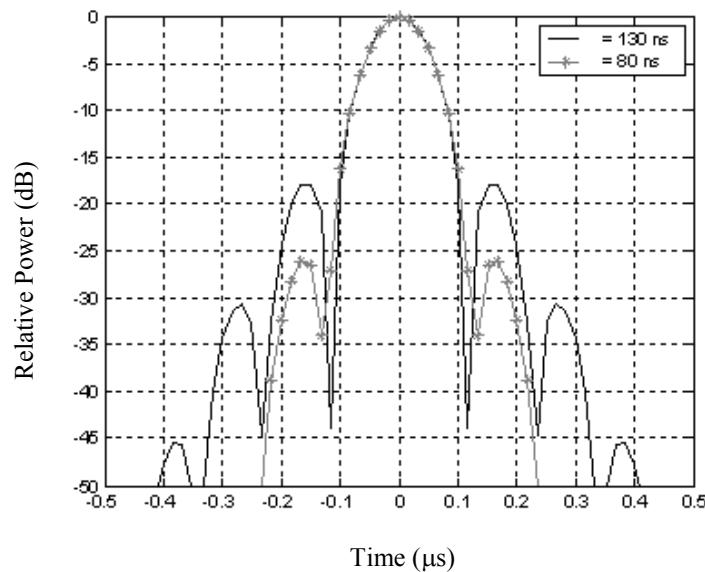

Figure 2-6: Comparison of the Autocorrelation Functions of the GWS Kernel for $\sigma = 80$ ns (Asterisked Curve) and 130 ns (Solid Curve).

The preceding approach for creating spectrally clean waveforms was ad-hoc in that only two sampling functions were considered, the sinc function and a Gaussian-weighted sinc function, both of which are ideal theoretical time-domain signals because they have infinite temporal extent. Further work is needed to address optimizing the selection of a spectrally clean waveform for an appropriate class of sampling functions. Moreover, special consideration should be given to investigating a class that includes physically realizable waveforms [89] and to understanding the implications of basing analyses on ideal waveforms. Even though it is spectrally confined, the basic cardinal-series sampling expansion (sinc kernel only) is unacceptable, because it induces leading and trailing time-domain edges of the pulse that continue for a long time. Moreover, the transmitter would be forced to emit small amounts of energy for long periods of time, thereby reducing the efficiency of a transmit-receive module. On the other hand, a significant reduction in the leading and trailing edges was achieved with the GWS function, but at the cost of increasing the bandwidth and the near-in time sidelobes around the mainlobe.

2.2.2 Spectrally Clean Transmitter Design

Managing the power spectrum of a radar waveform is critical to minimizing the effects of spectral spreading and intermodulation products on adjacent channels or the effects from other regulated bands that interfere with the radar (S-band, X-band, etc.). A Chireix out-phasing scheme achieves linearity and power efficiency by putting two phase-modulated coded waveforms through separate PAs and summing the outputs [23]. Using PAs to implement the Chireix technique is called a LiNC (Linear amplification with Non-linear Components) transmitter. This implementation requires several hardware components: a parallel architecture of two PAs, a 180° hybrid to sum the phase-modulated outputs of the two PA branches, and a cascade of a phase trimmer and attenuator on one PA output branch to adjust for amplitude and phase imbalances between both PA branches. In general, the PAs are driven into saturation to maximize power efficiency while simultaneously achieving high linearity. Maintaining amplitude and phase matches between both PA branches is a challenging problem when using this technique, and many attempts have been made to address this problem with some success. The NRL work concentrated on improving the understanding needed for developing PAs that offer sufficient linearity and efficiency, which traditionally have been mutually exclusive in traditional PA design. To that end, hardware and a test bed were developed that took spectral measurements of various waveforms for various test conditions. In addition, experiments were conducted to explore the linearity issue with non-linear PAs under different drive conditions.

Figure 2-7 depicts the NRL hardware implementation of a linear spectrally clean waveform, and Figure 2-8 shows the measured data for the spectrally clean GWS with a 64-bit pseudo-noise code and the analytically predicted calculation of it at the input to the PA. Linear PAs under linear conditions were used to obtain this result. Good agreement between the calculated and measured results was obtained. In fact, the goal of an instantaneous spectral bandwidth of 20 MHz at 100 dB down was achieved in this special case.

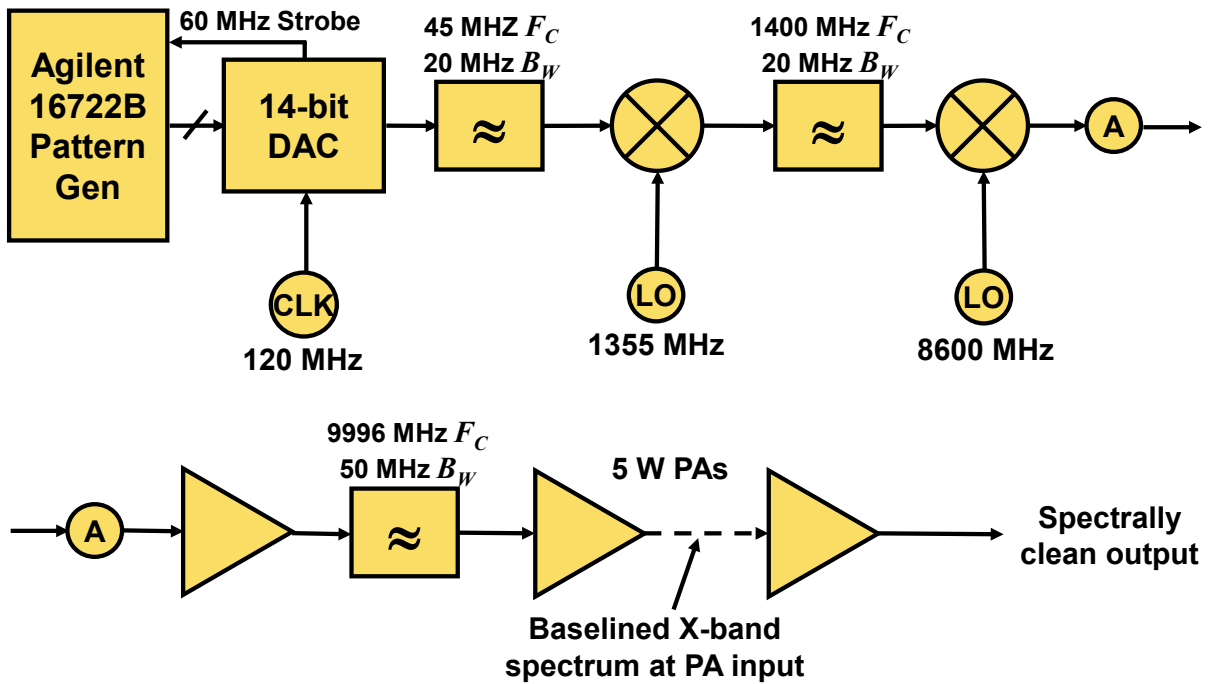

Figure 2-7: Hardware Implementation of Linear Spectrally Clean Waveform.

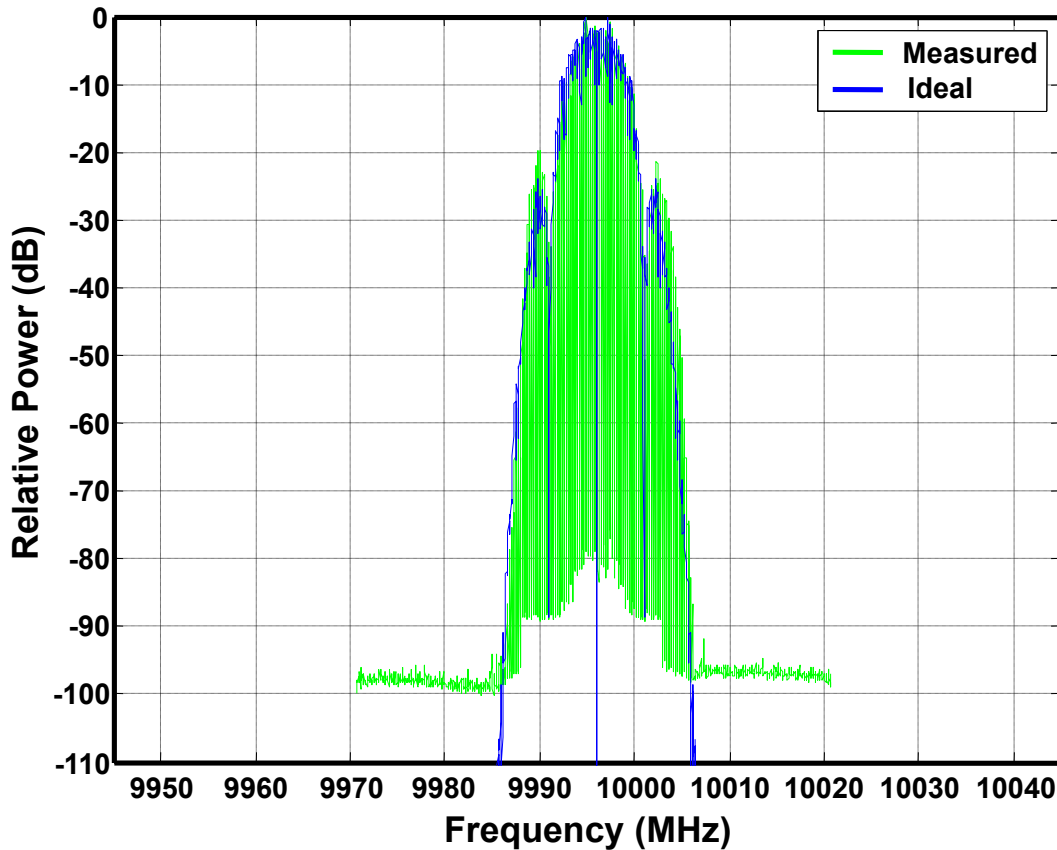

Figure 2-8: Comparison of Ideal and Measured Spectra of GWS Waveform at Input to PA.

To test the capability of the Chireix method, an out-phased X-band transmitter was designed and built (Figure 2-9). When the method was tested using amplifiers in a linear mode, the amplifiers were not well matched and had some third-order inter-modulation products. The preliminary indications (Figure 2-10) strongly suggested that the Chireix out-phasing system was capable of producing a spectrum 100 dB down (Figure 2-10); however, when the GWS waveform with a 64-bit pseudo-noise code was tested on the X-band transmitter of Figure 2-9, the spectrum was only down 70 dB from the peak outside a 35 MHz band (Figure 2-10). Also, spectral spreading from the inter-modulation products occurred outside the desired 20 MHz band at 50-55 dB below the peak. In the literature, the term *spectral re-growth* commonly refers to the non-linear effects of a PA. Although this performance did not meet the originally specified spectrally clean requirement for the linear mode, these results were a significant improvement over the spectral performance of existing waveforms (PSK, MSK, DPSK) with constant-envelope methods.

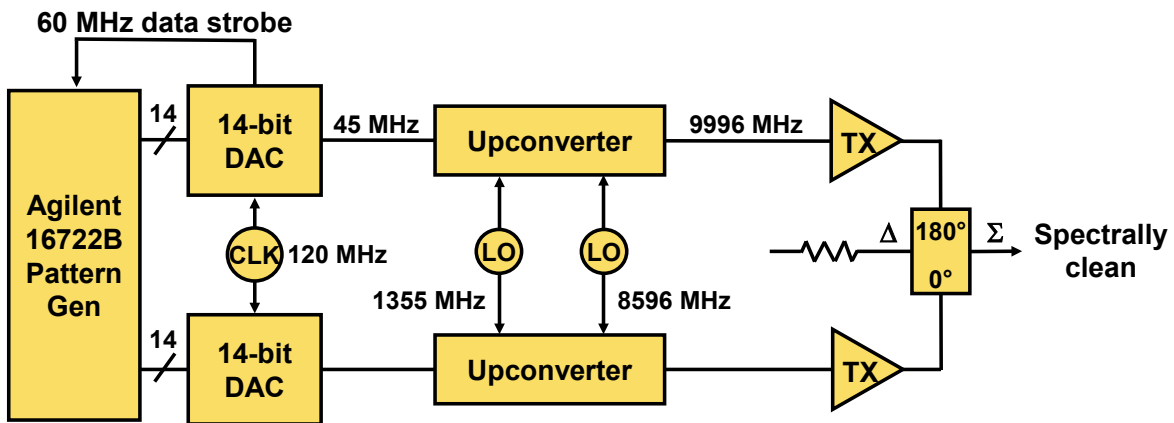

Figure 2-9: Implementation of Out-Phased X-Band Transmitter.

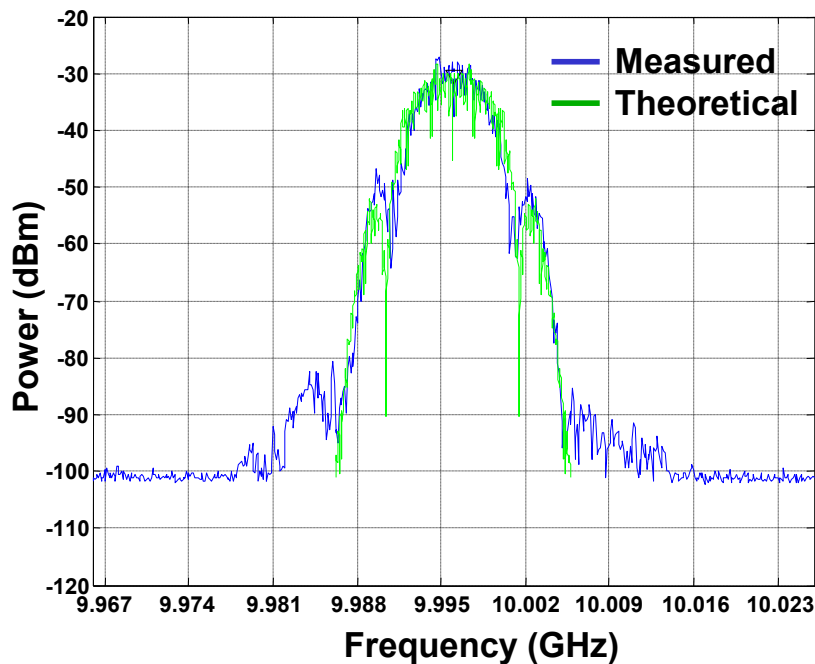

Figure 2-10: X-Band Output of Spectrally Clean Waveform Using Linear Chireix Out-Phasing System (Sum Channel) of Figure 2-9.

In a more detailed enlargement of the right side of the out-phased X-band transmitter of Figure 2-7 (Figure 2-9), the constant-envelope phase-modulated signal $m(t)$ generated for each channel is driven into a driver stage which consists of a cascade of one calibrated variable attenuator, two X-band high-IP3 amplifiers, and two isolators to control the VSWR. In a nutshell, the basic goal of this effort was to design $m(t)$ to band limit at the sum port and to minimize energy (residue) at the difference port.

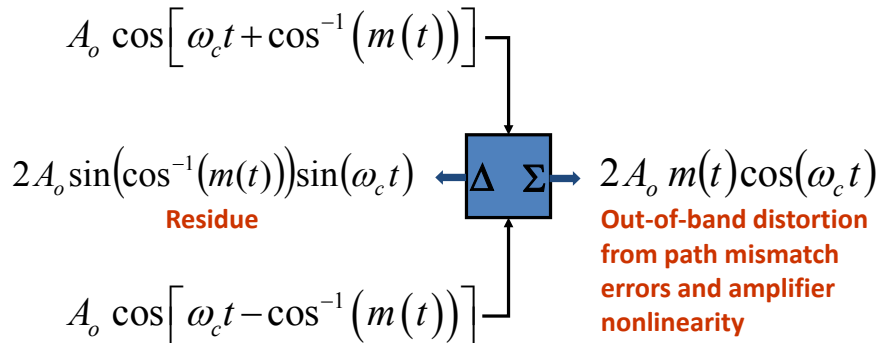

Figure 2-11: Constant-Envelope Phase-Modulated Signal $m(t)$ Generated for Each Channel.

The measurements in this early research on spectrally clean research showed that PAs must operate at a saturated power levels at the expense of linearity to obtain the maximum efficiency. Conversely, to improve the linearity, the PA must operate below the P1dB point at the expense of efficiency. In traditional PA design, the designer trades linearity versus efficiency. The possible advantage of the Chireix scheme is the promise of achieving both high linearity and high efficiency. However, many hurdles must be overcome if the Chireix (or an alternate) scheme is to be viable for a real radar system. In particular, joint optimization of the waveform design and PA network should produce better performance, and the research groups at Baylor University and University of Kansas, headed by Dr. Charles Baylis and Dr. Shannon Blunt, respectively, are attacking this problem. Some of that effort on reconfigurable amplifier design for flexible spectral mask compliance is discussed in Section 2.4. For additional details, see Ref. [83].

In summary, primary goals for achieving spectrally confined radar waveforms under the early NRL programs were:

- 1) To create transmitted magnitude spectra with values that satisfy some official spectral mask (are more than some specified dB down outside of some instantaneous specified bandwidth that is centered about the peak magnitude);
- 2) To preserve the original autocorrelation function of the waveform as much as possible; and
- 3) To minimize the time extent of any leading or trailing tails of the waveform.

2.2.3 Other Recent and Current Efforts on Improving Transmitter Spectral Cleanliness

From the 2005 to the present, the NRL radar efforts continued through internal programs and collaborations with the University of Kansas (Dr. Blunt) and Baylor University (Dr. Baylis) on waveform design [12], [13], [41], [14], [15], [16], [17], [18] and jointly optimizing waveform design and the PA circuitry [9], respectively. Their current efforts on controlling the rise and fall times of pulses and reconfigurable amplifier design for flexible compliance with spectral masks are discussed in Sections 2.3 and 2.4.

Currently, the NRL Radar Division is heavily involved with U.S. Navy’s Electromagnetic Environmental Effects (E3) program, the U.S. DoD Spectrum S&T Working Group of the Defense Information Systems Agency (DISA), and the Shared Spectrum Access for Radar and Communications (SSPARC) program of the

U.S. Defense Advanced Research Projects Agency (DARPA BAA-13-24). Each effort directly addresses radar spectrum problems in the USA.

For the E3 effort, Lawrence Cohen of NRL radar has been supporting the U.S. DoD's Electromagnetic Environmental Effects (E3) program, which promotes communications, coordination, commonality, and synergy for E3 engineers and spectrum management professionals. It also provides an information exchange forum for the DoD, the Federal government, and industry to address policy, operation, doctrine, standardization, etc. For the past eight years, Mr. Cohen has been conducting spectrum testing and has been alerting U.S. radar designers about spectrum issues and their possible solutions. In addition, he is currently involved in obtaining better characterization of the EMI generated by crossed-field amplifiers in high-power radars and the subsequent contribution to out-of-band interference, especially to communication systems such as WiMAX and LTE in adjacent channels.

For the DISA effort, the NRL SET-182 team provided subject-matter expertise on radar-communication issues. In particular, an NRL radar proposal was used as the kernel for DISA's strategic spectrum plan and for selected S&T efforts to address issues associated with the sale of portions of primary radar spectrum to commercial communication companies.

For the SSPARC program, NRL radar has been supporting DARPA on spectrum sharing:

- 1) Between military radars and military communications systems to increase both capabilities simultaneously when operating in congested and contested spectral environments.
- 2) Between military radars and commercial communications systems that preserves radar capability while meeting national and international needs for increased commercial communications spectrum, without incurring the high cost of relocating radars to new frequency bands.

Phase 1 of the SSPARC program has four tasks:

- Co-existence system concepts (especially between legacy radars and communication systems);
- Co-design of radar and communication systems;
- Supporting technologies; and
- Theory and fundamental limits.

In addition, two U.S. members (Mr. Cohen and Dr. Mokole) of the SET-182 team wrote the NATO CSO's Technology Watch on "Adaptive Solid-State Power Amplifiers and Optimized Waveforms" in 2014 to help inform the CSO on one important area of research and development for good spectrum use and compatibility.

2.2.4 Technology Watch: Adaptive Solid-State Power Amplifiers and Optimized Waveforms

2.2.4.1 Description of the Technology

Wireless systems like WiMAX and 4G have begun to operate worldwide at S-band (2 – 4 GHz), historically the preferred frequencies for large high-power military surveillance radars. These wireless systems have been causing substantial spectrum congestion, particularly just above 3500 MHz. To exacerbate the problem, high-power S-band radars interfere with wireless systems in adjacent frequency bands, because radar transmissions introduce sufficient energy in those bands. A major contributor to out-of-band interference to wireless systems is the current generation of radar solid-state power amplifiers (TRL 9), which are used in many in-service radars, both for active phased arrays and lumped transmitter radars. Also, digital adaptive waveform synthesis and generation for digital adaptive beamforming in active phased array radars, currently in production (TRL 9), can be improved. Given the current state of PAs, the need for a Technology Watch,

which is about keeping an eye on emerging technologies with potentially beneficial consequences for military capability, lies in the sharing of congested frequency space and the consequential need to control spectral purity to a far greater degree than has been previously required.

To be more spectrally compatible with other users of the Radio-Frequency (RF) spectrum, radar designers are looking more closely at adaptive solid-state PAs as a possible technological solution. In particular, radar developments are supporting components for in-service and new acquisition radar transmitters that provide the requisite performance goals while contributing less out-of-band spectral products than vacuum-tube transmitters (for example).

Some current solid-state radars have thousands of X-band Transmit/Receive (T/R) modules supporting an electronically steered active array antenna. For example, the Thales Active Phased Array Radar (APAR) is deployed on NATO ships like the German Navy's Sachsen class in a 4-APAR configuration to provide full 360° azimuthal coverage. However, in order to reduce out-of-band spectral emissions, radar transmitter designers often rely either on increasing the rise and fall times of the drive pulse that feeds a solid-state PA, such as Gallium Nitride (GaN), or resort to linearization techniques such as pre-distortion or the Doherty method. In one approach for reducing PA-induced out-of-band interference, an S&T effort [38] has developed a mathematical algorithm for optimizing the impedance seen by the output of a solid-state PA, known as load-pull optimization, to increase the in-band signal power while simultaneously reducing the out-of-band spectral products. This algorithm relies on a Pareto optimization routine that can select through as little as 5 points in a region on a Smith Chart of complex load impedances, thereby permitting a solid-state PA to maximize its desired in-band RF power while reducing out-of-band spectral products. Just recently, this research incorporated the adjustment of the spectral and temporal characteristics of waveforms prior to amplification, thus providing an additional dimension to the in-band and out-of-band optimization of the power spectral density. Currently, this work is incorporating bench-level testing.

The application of adaptive solid-state PAs and waveforms will better support Digital Beam Forming (DBF) for advanced electronically steered array radars in terms of performance and spectral compatibility with other radars and communications systems by allowing real-time changes to the temporal and spectral characteristics of the RF drive power to the antenna elements comprising the array. Ultimately, Microwave Monolithic Integrated Circuits (MMIC) devices may be designed and fabricated that incorporate the PA, load-pull circuitry, and waveform-synthesis and optimization-software routines that can be applied to legacy and new acquisition radars. To achieve the functionality of adaptive PAs for enhanced performance and spectrum compatibility, the following two enabling technologies are critical:

- Adaptive waveform synthesis and generation; and
- MMIC devices incorporating adaptive PAs, load-pull circuitry, and waveform generation and synthesis.

2.2.4.2 Possible Impact of the Technology on a Military Capability

- **Own Forces:** This technology has the potential to improve a simultaneous search and track capability through Digital Beam Forming (DBF) supported by adaptive solid-state PAs for the interdiction of multiple-air, varying altitude targets in both littoral and blue-water scenarios. Furthermore, this technology is resistant to jamming and Electromagnetic Interference (EMI), yet contributes to spectrum compatibility with military and civilian wireless communication systems. Spectrum compatibility is maintained by the ability of adaptive PAs to attenuate out-of-band spectral products, thus minimizing the opportunity for adjacent-band interference with military and civilian wireless systems.
- **Adversaries:** This technology is more capable operationally than the conventional rotating reflector and phased array vacuum-tube type radars still often in use by NATO adversaries and is far beyond the current capability of terrorist forces. However, NATO adversaries employ more and more advanced

active electronically steered phased array radars. For example, the Chinese Type-052C destroyer features a four-array, multi-function, phased array radar that provides 360° coverage. This radar is used in conjunction with vertically launched HHQ-9 long-range air-defence missiles, and each element is capable of transmitting and receiving, a functionality similar to the United Kingdom's SAMPSON active phased array radar. Adversarial capability is currently not yet as advanced as the technologies described in this Tech Watch – but it is rapidly advancing.

2.4.4.3 Technology Readiness Level

The maturity for the enabling technologies is increasing at a very rapid rate and is currently TRL 4, because such MMIC modules could be available within 5 years, given the proper level of funding.

2.4.4.4 Related to NATO Requirements

2.4.4.4.1 Long-Term Aspects of the Minimum Capability Requirements (2012)

- ABMD – Active Ballistic Missile Defence.
- CLSAT – Counter Low-Signature Airborne Targets.
- ISR-CC – Intelligence Surveillance and Reconnaissance (ISR) Collection Capability.

2.4.4.4.2 Defence Against Terrorism Programme of Work

#2 – Protecting Harbours and Vessels from Surface and Sub-Surface Threats.

2.3 CONTROLLING THE PULSE RISE/FALL TIME

There has been considerable research in the area of waveform design and optimization (e.g., [66], [99], [81], [43] and references therein). While Frequency-Modulated (FM) waveforms are attractive from a physical implementation standpoint (e.g., via Surface Acoustic Wave (SAW) device or Arbitrary Waveform Generator (AWG)), the inherent structure of codes is attractive because optimization can be readily performed by searching over the parameters of the code space. Furthermore, the recent development of a scheme for the physical implementation of arbitrary polyphase codes as continuous waveforms now makes it feasible to optimize FM waveforms directly. Based on the Continuous Phase Modulation (CPM) framework used in some digital communication standards that require strict power and spectral efficiency, these new Polyphase-Coded FM (PCFM) radar waveforms are not only amenable for use with a high-power transmitter [15], [16], [63], [19], [20], they can even be optimized with the hardware-in-the-loop to be specially tuned for the distortion of a specific transmitter [64], [20]. As such, the impact of different transmitter components and topologies can now be considered jointly with the waveform in a holistic manner to address both the spectral containment and the goodness of a radar emission for sensing. Here we demonstrate a particular instantiation of the general Linear amplification using Non-linear Components (LiNC) paradigm that employs a 180° coupler [84], [6].

To maximize power efficiency and thus energy-on-target, a common radar requirement is for the transmitter Power Amplifier (PA) to be operated in saturation. The constant modulus and relatively bandlimited attributes of FM waveforms naturally helps to negate some of the effects of operating in the non-linear regime of the PA. However, this non-linearity also precludes the use of an amplitude taper to improve the spectral containment of the transmitted waveform by “slowing down” the otherwise rapid rise/fall-time of the pulse. The LiNC strategy addresses this issue by using two matched power amplifiers. The amplifier outputs are combined in a 180° coupler, with their relative phases determining the amplitude of the resulting waveform.

The LiNC approach is a powerful tool that allows for the creation of waveforms that could not be easily implemented with a single amplifier design. With this set-up, it is possible to apply an amplitude taper to a pulse without experiencing the negative non-linear effects that would otherwise occur. Tapering is well known as a means to reduce range sidelobes for a linear FM (LFM) chirp [66]. The difficulty is that tapers are very problematic to implement with a single saturated amplifier. However, if the output amplitudes of two parallel amplifiers can be calibrated to match reasonably well, then amplitude manipulation of the resulting emission can be attained through the relative phase of the two input waveforms. What makes the LiNC technique so useful is that it effectively mimics a linear amplifier while retaining high power efficiency and thus most of the high output power (relative to the original sharp rise/fall-time some power is still lost due to amplitude tapering the pulse edges).

2.3.1 LiNC-PCFM Radar Implementation

Continuous Phase Modulation (CPM) is used in a variety of applications such as aeronautical telemetry and deep-space communications and forms the basis of the Bluetooth wireless standard. The primary advantages of CPM are good power efficiency (constant modulus) and good spectral efficiency (tight spectral roll-off). Both of these factors are very important to radar systems in order to get the most energy on target while maintaining required spectral containment. The CPM framework, modified to implement polyphase radar codes and thereby generate Polyphase-Coded FM (PCFM) waveforms [15], [16], [63], [19] is shown in Figure 2-12.

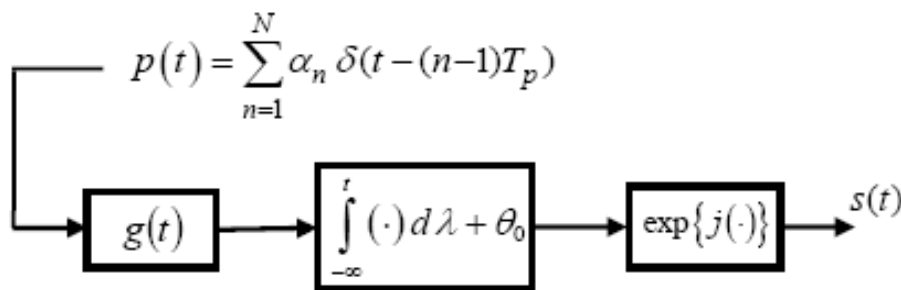

Figure 2-12: PCFM Radar Waveform Implementation.

The input $p(t)$ is a train of N impulses with separation T_p such that the total pulsewidth is $T = NT_p$. The phase change between successive chirps in the code is defined as:

$$\alpha_n = \begin{cases} \tilde{\alpha}_n & \text{if } |\tilde{\alpha}_n| \leq \pi \\ \tilde{\alpha}_n - 2 \operatorname{sgn}(\tilde{\alpha}_n) & \text{if } |\tilde{\alpha}_n| > \pi \end{cases} \quad (2-4)$$

where:

$$\tilde{\alpha}_n = \theta_n - \theta_{n-1} \quad \text{for } n = 1, \dots, N, \quad (2-5)$$

and θ_n is the phase of the n^{th} element in a length of $N + 1$ polyphase code. The resulting baseband output $s(t)$ is a form of non-linear FM that can be modulated onto a carrier.

For the LiNC configuration using a 180° coupler [84], [6], two continuous FM-based waveforms $s_1(t)$ and $s_2(t)$ are generated. Following separate power amplification (via PA 1 and PA 2 as shown in Figure 2-13), their relative phases combine in the sum (Σ) channel to create a phase-modulated pulse $e(t)$ whose amplitude follows some desired shape while the difference (Δ) channel is connected to a load to absorb the cancelled power at the beginning and end of the pulse. For example, the two waveforms may be designed so that their relative phases produce a Tukey pulse amplitude shape that permits control of the spectral content by

controlling the speed of the rise/fall-time (while still retaining the power efficiency benefits of saturated PAs).

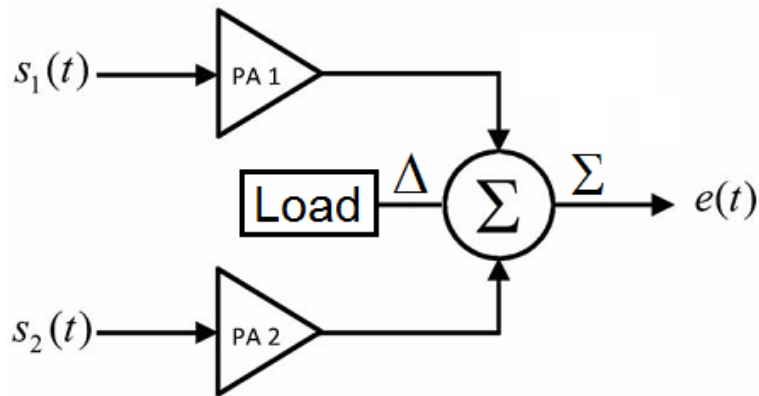

Figure 2-13: 180° Coupler LiNC Transmitter Implementation.

By controlling the relative phase of $s_1(t)$ and $s_2(t)$ as shown in Figure 2-14, the amplitude tapering of $e(t)$ is produced. To generate the tapering effect, waveform $s_2(t)$ may be modified with respect to waveform $s_1(t)$ at the beginning and end of the pulse by changing the associated values of α_n for the second waveform. It can be observed in Figure 2-14 that the two waveforms start at 180° (π radians) out-of-phase at the beginning of the pulse, slowly become in-phase and remain that way over the middle of the pulse, and then move back to out-of-phase by the end of the pulse.

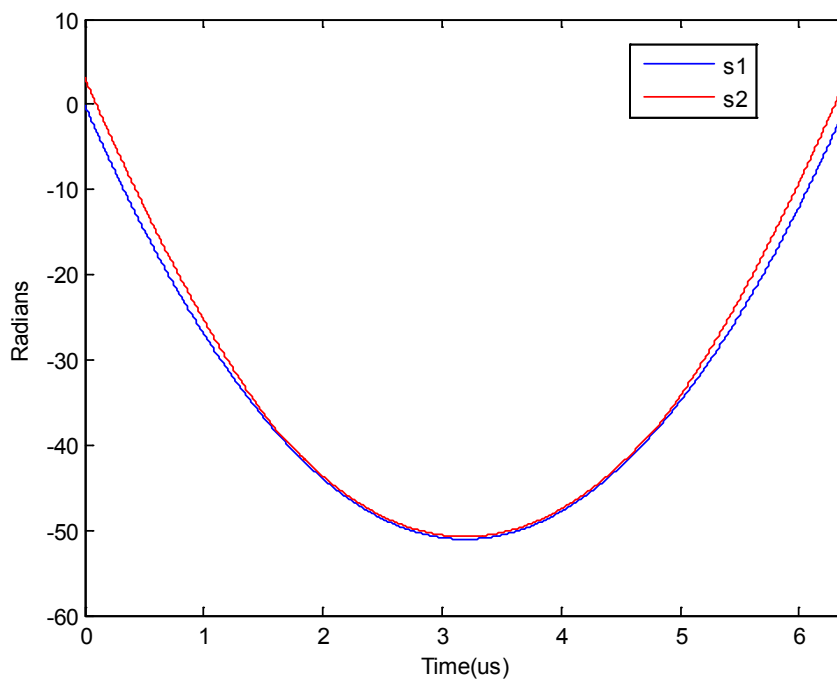

Figure 2-14: Unwrapped Phase of Waveforms $s_1(t)$ and $s_2(t)$.

Mathematically, this implementation can be represented as:

$$s_1(t) = s(t) \tag{2-6}$$

$$s_2(t) = s(t) \exp\{j\phi(t)\} \quad (2-7)$$

where:

$$\phi(t) = \cos^{-1}(2w^2(t) - 1) \quad (2-8)$$

is the phase adjustment for $s_2(t)$ and $w(t)$ is the desired amplitude window. The output waveform $e(t)$ is thus:

$$e(t) = s_1(t) + s_2(t) = s(t)w(t) \exp\{j\psi(t)\}, \quad (2-9)$$

where:

$$\psi(t) = \tan^{-1} \frac{\sqrt{1 - w^2(t)}}{w^2(t)} \quad (2-10)$$

is a residual phase response that is produced when combining the two waveforms of (3) and (4) within this LiNC configuration. Because the amplitude weighting and associated phase response modify the underlying waveform $s(t)$ in (6), it is necessary to optimize the output emission $e(t)$ according to the desired specifications (e.g., peak sidelobe level, integrated sidelobe level, range resolution) even if the underlying waveform $s(t)$ has already been optimized.

Consider the Tukey taper applied to the rise/fall-time of a 64 μ s pulse. To achieve the desired degree of spectral containment, the transition length of the taper is one quarter of the pulsewidth at the beginning and at end of the pulse. This amplitude taper produces a 1.7 dB loss in transmit SNR. If such a taper is generated for an LFM waveform via (6) using the 180° coupler configuration, the measured spectrum in Figure 2-15 is realized where the spectral containment is clearly improved by as much as 20 dB. However, this Tukey-tapered LFM yields a Peak Sidelobe Level (PSL) of only -16.38 dB. To address this rather limited sensitivity due to high-range sidelobes, Hardware-In-the-Loop (HIL) optimization can be performed that yields the measured spectrum in Figure 2-16. By accounting for both the tapering and the transmitter distortion this emission realizes a PSL of -42.81 dB, a 26.4 dB improvement. More details can be found at Ref. [86].

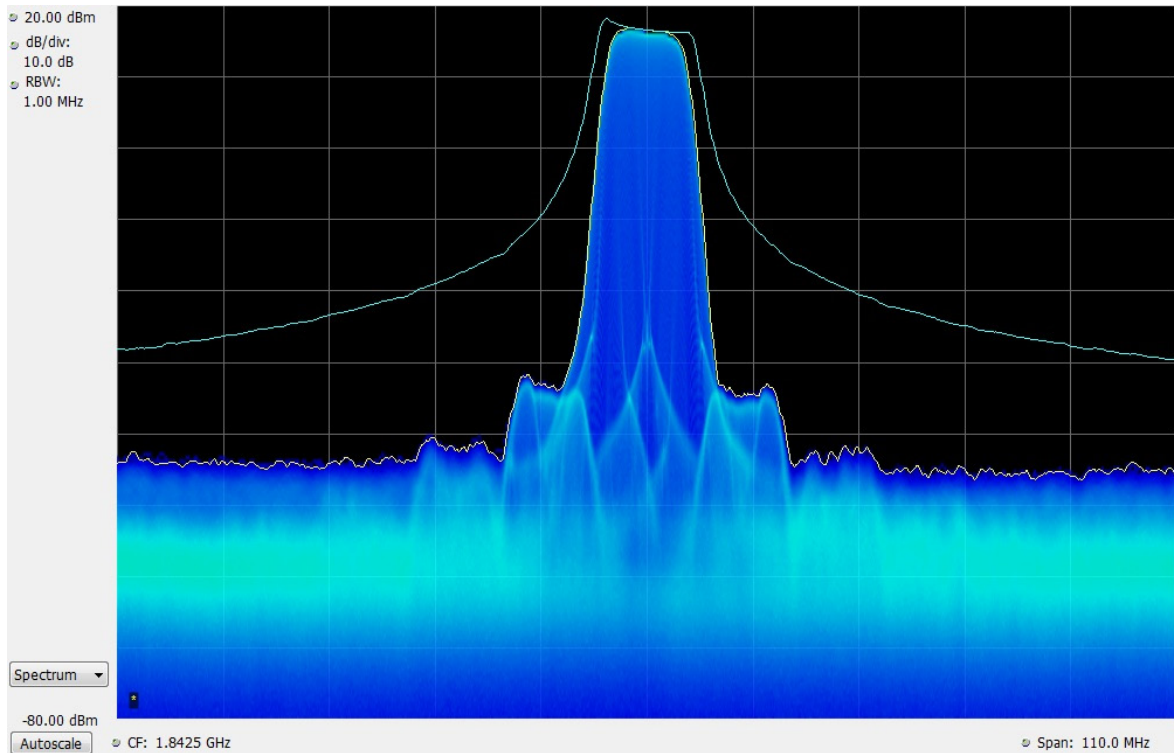

Figure 2-15: LFM Spectrum with Tukey Taper (Bottom Trace) and Without (Top Trace) for a Frequency Span of 110 MHz and 10 dB/Division Vertical Scale as Captured by a Spectrum Analyser.

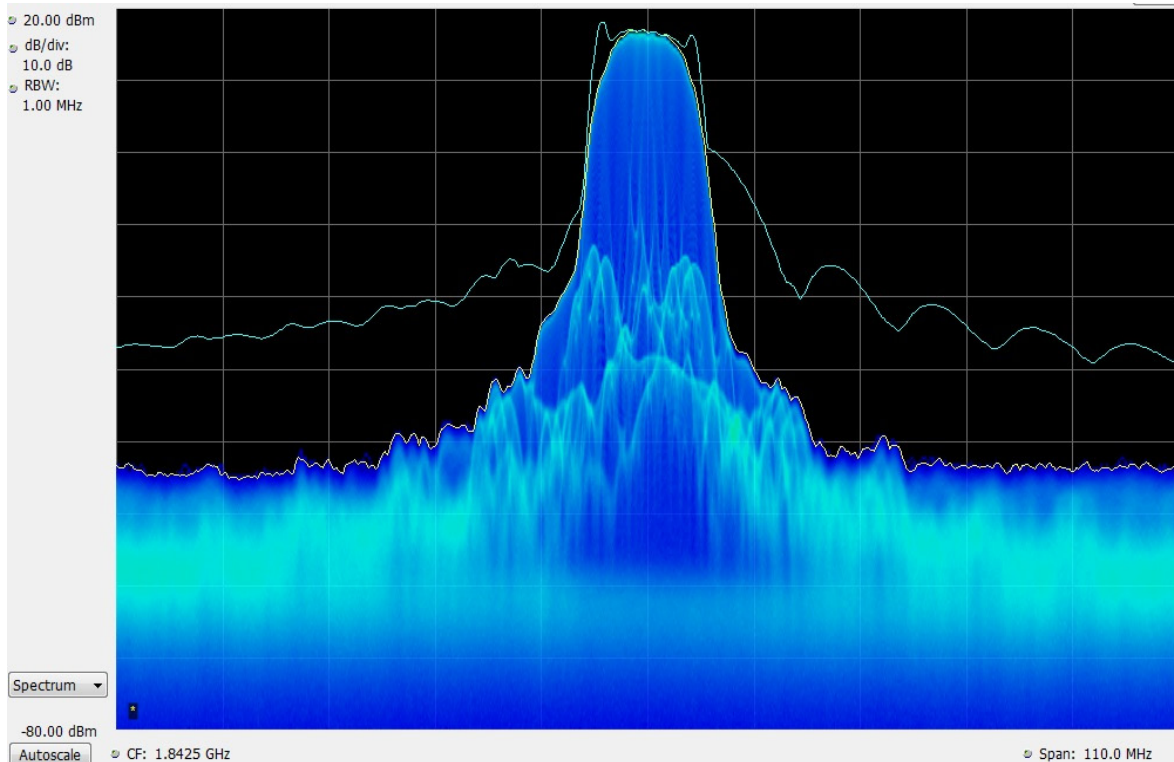

Figure 2-16: Hardware-Optimized Spectrum with Tukey Taper (Bottom Trace) and Without (Top Trace) for a Frequency Span of 110 MHz and 10 dB/Division Vertical Scale as Captured by a Spectrum Analyser.

2.4 RECONFIGURABLE AMPLIFIER DESIGN FOR FLEXIBLE SPECTRAL MASK COMPLIANCE

Because of tightening spectral constraints, transmitter amplifiers (especially in radar systems) are hard-pressed to meet changing requirements. A proposed solution to this problem is the joint optimization of the circuit and waveform to provide spectral compliance while achieving objectives of:

- 1) Detection capability (as manifested in the ambiguity function of the radar transmitter output waveform); and
- 2) High Power-Added Efficiency (PAE) of the power amplifier.

This section overviews efforts to design optimization routines capable of optimizing the load impedance and radar waveform to meet spectral requirements and obtain these objectives. This section presents results of this work, funded during the period of the SET-182 Research Task Group first by the United States Naval Research Laboratory and, presently, by the United States National Science Foundation (Award Number ECCS-1343316).

The techniques explained in this section are developed with a future radar system in mind. Many future radar systems may be cognitive and/or adaptive, and will have to function within the protocol known as Dynamic Spectrum Access (DSA). In DSA, secondary users can “borrow” unused spectrum from the primary users assigned to that spectrum. For adaptive radars operating in a changing spectrum environment, the transmitters must be frequency agile. This requires reconfigurable microwave circuitry in the power amplifier of the transmitter.

A conceptual block diagram of a future radar transmitter’s power amplifier is shown in Figure 2-17, as presented by SET-182 members in a recent IEEE *Microwave Magazine* article [9]. The amplifier uses a tunable load network, implemented in MEMS or varactor technology. It is controlled by a Field-Programmable Gate Array (FPGA) or other cognitive radio platform. A spectrum analyzer and power sensor will need to be present as part of the design to assess the Power-Added Efficiency (PAE) and spectral mask compliance of the amplifier and its output waveform. An adaptive amplifier module for cognitive radar has recently been proposed in the literature by Kingsley and Guerci [65], who describe implementation and optimization for different objectives.

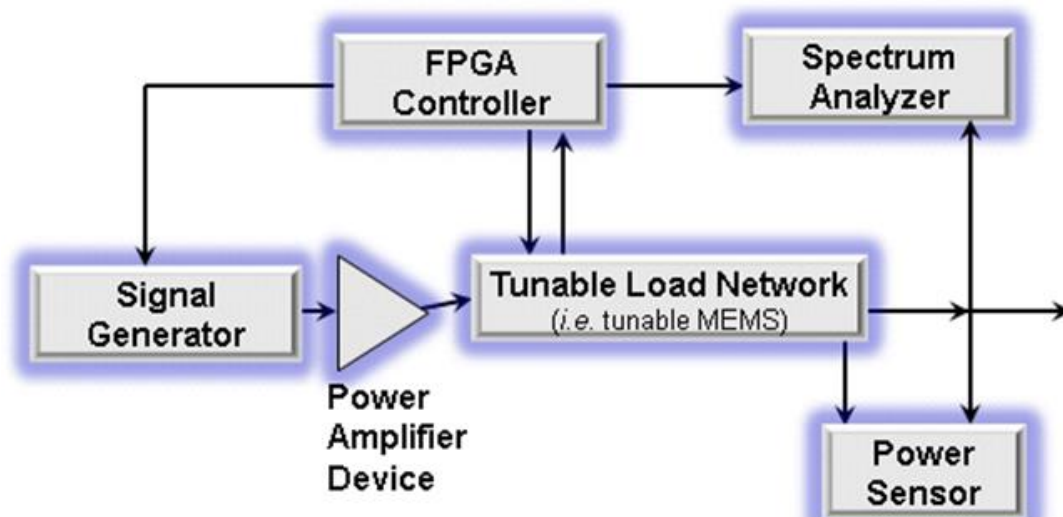

Figure 2-17: Future Radar Transmitter Power Amplifier (Reprinted from [9]).

At Baylor University, SET-182 member Charles Baylis, in collaboration with Robert J. Marks II, research students, and SET-182 member Lawrence Cohen of the United States Naval Research Laboratory, have developed algorithms during the term of this Task Group to jointly optimize circuit and waveform using a non-linear optimization test platform (Figure 2-18). The test platform consists of a Maury Microwave Automated Tuner System (ATS) with load-pull tuners and controller, an Agilent vector signal generator, and an Agilent power meter/sensor and spectrum analyzer, with additional use of a LeCroy 5 GHz oscilloscope for time-domain data to calculate ambiguity functions.

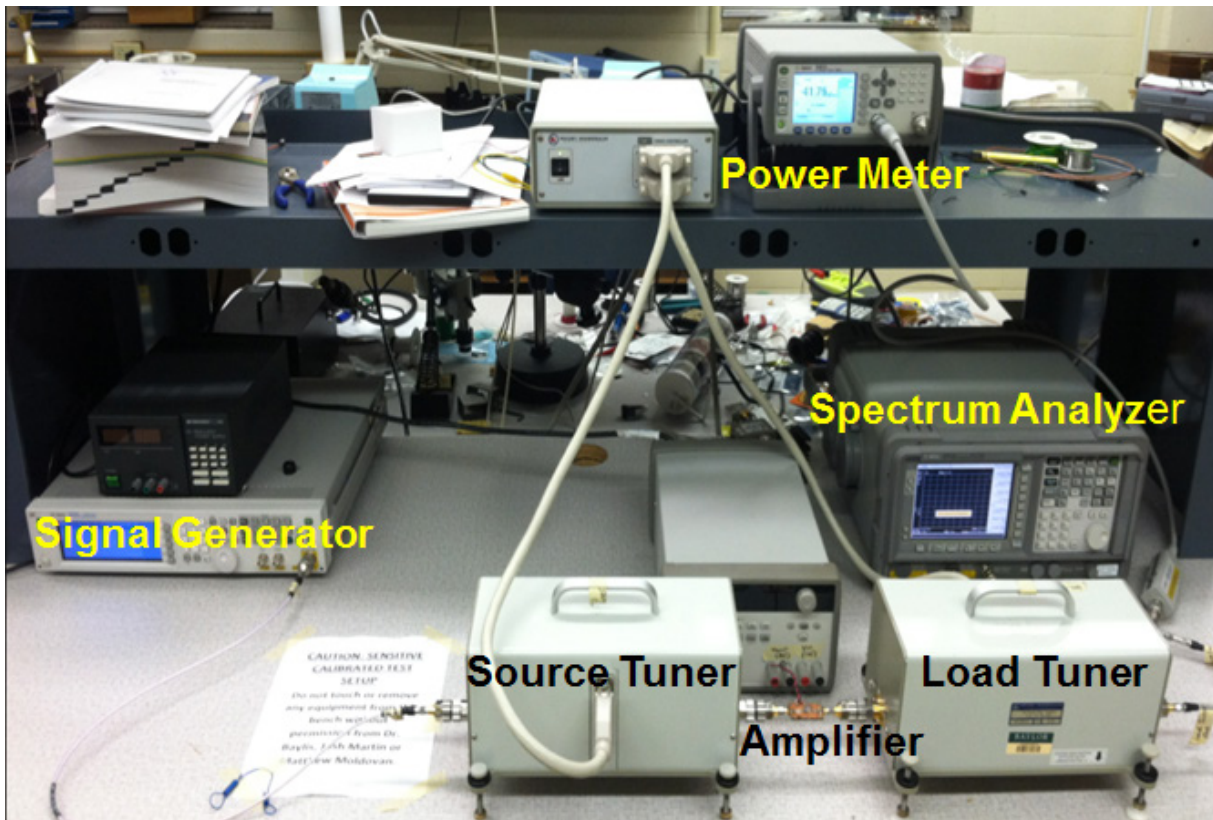

Figure 2-18: Baylor Non-Linear Optimization Test Platform.

Several innovations in the area of real-time circuit optimization algorithms are presented in the following sub-sections, including the following:

- 1) Fast load-impedance search for power-added efficiency and adjacent-channel power ratio;
- 2) Load-impedance optimization based directly on PAE and spectral mask compliance;
- 3) The Smith Tube for joint circuit and waveform optimization; and
- 4) A fast Smith Tube measurement search for chirp bandwidth and amplifier load-impedance optimization.

2.4.1 Fast Load-Impedance Search for Power-Added Efficiency and Adjacent-Channel Power Ratio

The first step in building joint circuit and waveform optimization has been the consideration of how to optimize the load reflection coefficient Γ_L (related to the load impedance Z_L) of the power amplifier to obtain the highest Power-Added Efficiency (PAE) possible while remaining under limitations placed upon the

Adjacent-Channel Power Ratio (ACPR). This sub-section details material described in a recent publication [37]. Spectral spreading in power amplifiers is significantly a function of the non-linearity in the power amplifier, and is created by odd-order intermodulation distortion in the amplifier.

A constrained optimization is required, maximizing one of the objectives (PAE) while remaining within constraints on the other (ACPR). The collection of constrained optima in the Smith Chart is known as the Pareto optimum locus, and is displayed in Figure 2-19. This plot displays the PAE and ACPR contours as simulated by a load-pull simulation in Advanced Design System (ADS) from Agilent Technologies. The Pareto optimum locus connects the PAE optimum and the Pareto optimum, but is not a straight line; rather, it consists of Γ_L values for which the PAE and ACPR contours are collinear.

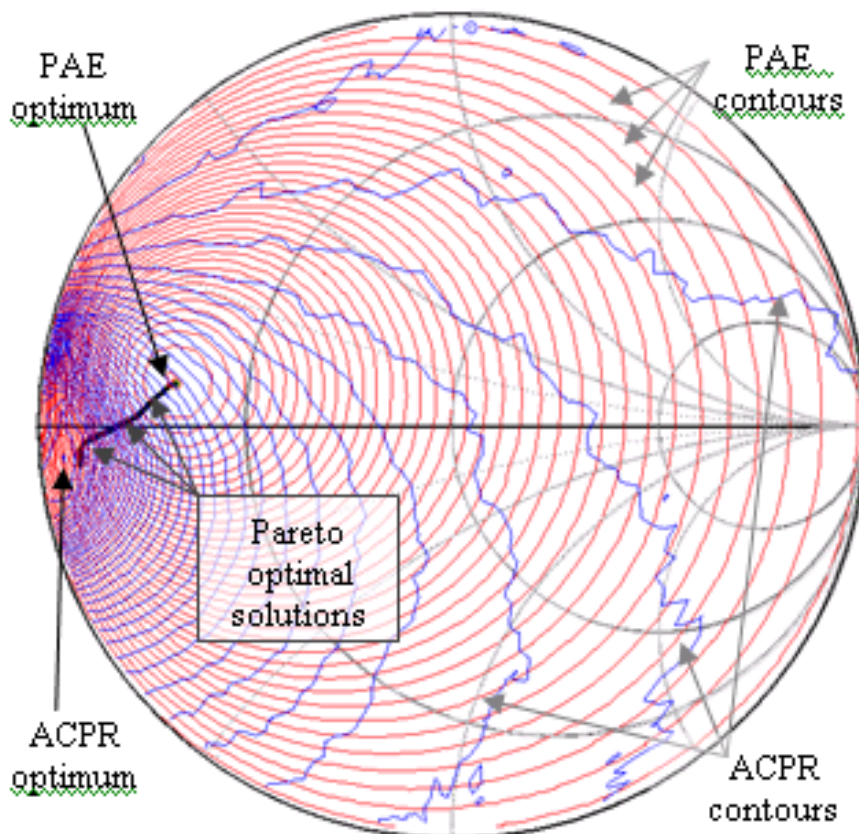

Figure 2-19: The Pareto Optimum Locus for a Simulated Power Amplifier Device, Displayed with PAE and ACPR Contours.

The goal of the optimization is as follows: starting from an arbitrary Γ_L , maximize PAE while maintaining ACPR below the required limit established based upon regulatory considerations. A vector-based search was created to perform this optimization in the Smith Chart. The first step is the measurement approximation of the PAE and ACPR gradients, performed by measuring PAE and ACPR surrounding values of Γ_L in the Smith Chart, as shown in Figure 2-20. These measurements are used to find \hat{p} , the unit vector in the direction of PAE steepest ascent, and \hat{a} , the unit vector in the direction of ACPR steepest descent. These unit vectors provide the optimal directions for the conflicting criteria at the candidate. These measurements are taken slightly above and to the right of the candidate at a user-specified neighboring-point distance D_n .

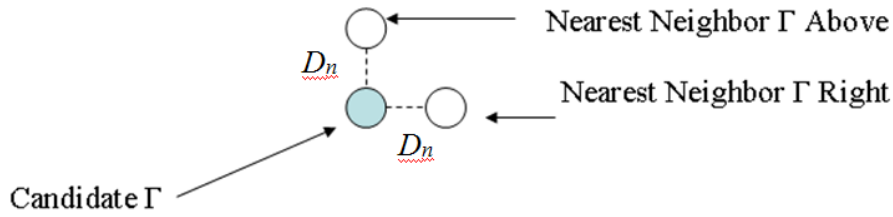

Figure 2-20: Measurement of Surrounding Values of Γ_L in the Smith Chart for PAE and ACPR Gradient Optimization.

After the gradients are calculated, a vector-based triangulation is performed based on the unit vectors and an estimate of the search's progress. Figure 2-21 shows how the subsequent candidate value of Γ_L is determined in the search. Figure 2-21(a) shows that if the initial candidate is within ACPR compliance, the search vector to the next candidate is a vector sum of a component in the direction of \hat{a} (toward the ACPR optimum) and the vector \hat{b} that bisects \hat{a} and \hat{p} . In this case, the search vector to the subsequent candidate is given by:

$$\vec{v} = \hat{a}D_a + \hat{b}D_b \tag{2-11}$$

where:

$$D_a = \frac{D_s}{2} \frac{|ACPR_{meas} - ACPR_{target}|}{|ACPR_{worst} - ACPR_{target}|} \tag{2-12}$$

and:

$$D_b = \frac{D_s}{2} \frac{|\theta_{meas} - \theta_{target}|}{\theta_{target}} \tag{2-13}$$

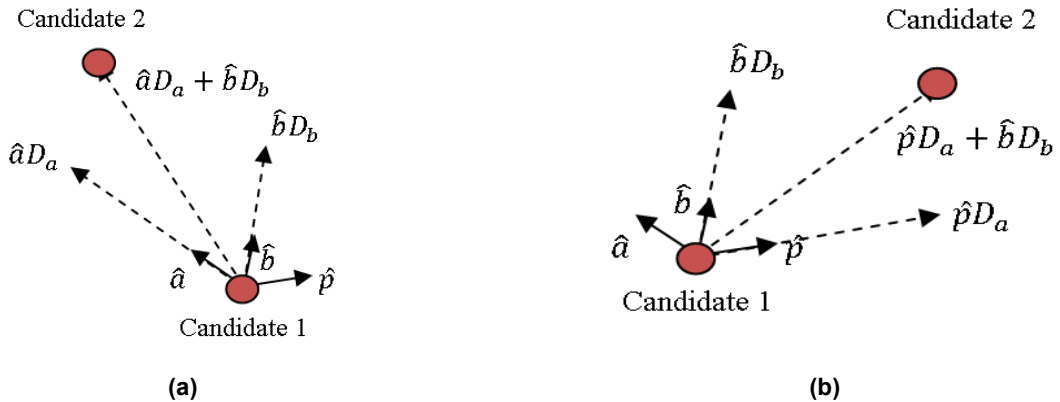

Figure 2-21: Determination of the Next Γ_L Candidate for the Cases: (a) $ACPR > ACPR_{target}$ (Out of Compliance) and (b) $ACPR \leq ACPR_{target}$ (in Compliance).

D_s is a search-distance parameter that is entered by the user. $ACPR_{meas}$ is the measured value of ACPR at the present candidate. $ACPR_{target}$ is the value of the ACPR limit constraint. $ACPR_{worst}$ is the highest value of ACPR that has been obtained since the algorithm began running. As such, equation (2) is an estimate of the percent of travel remaining from the starting point to the constraining ACPR value (which is expected to be the ACPR value at the sought optimum), and D_a tends to decrease as the constraint is approached. θ_{meas} is the angle between \hat{a} and \hat{b} at the candidate point. The value of θ_{target} is 90 degrees, because the gradients

of ACPR and PAE (and hence the vectors \hat{a} and \hat{p}) are collinear on the Pareto optimum locus. The desired constrained optimum will be on this Pareto optimum locus. Thus, this component will decrease in size as the Pareto optimum locus is approached. The search vector thus guides the search toward the ACPR constraint boundary and the Pareto optimum locus, the precise location of the expected solution.

If the initial candidate is not within ACPR compliance, the search vector to the next candidate is a vector sum of a component in the direction of \hat{p} (toward the PAE optimum) and the vector \hat{b} that bisects \hat{a} and \hat{p} . In this case, the search vector to the subsequent candidate is given by:

$$\vec{v} = \hat{p}D_a + \hat{b}D_b \tag{2-14}$$

where D_a and D_b are defined as in (2.12) and (2.13).

Once the search has arrived inside the ACPR acceptable region ($ACPR_{meas} \leq ACPR_{target}$), then some additional rules are placed on the search. If the next candidate is outside the acceptable region or has a lower PAE than the previous candidate, the search distance parameter D_s is divided by 3, and the search returns to the initial candidate and repeats with the smaller parameter. The search concludes when the search vector magnitude decreases below D_n .

Figure 2-22(a) shows traditionally measured load-pull contours for a Modelithics non-linear transistor model simulated in Agilent Advanced Design System software. This is a traditionally measurement of the variation of PAE and ACPR with changing Γ_L , and requires experimental queries at many values of Γ_L . For fine-resolution load-pull, hundreds of experimental queries can be used, requiring significant time for a measurement-based load-pull optimization. These contours can be used for comparison with the results of the intelligent algorithm. The constrained “Pareto” optimum is also displayed for ACPR compliance limitation of -45 dBc. Simulation results for the triangulation algorithm starting at $\Gamma_L = 0.8 \angle -90^\circ$ are shown in Figure 2-22(b). It can be seen that the constrained optimum is reached with only 11 experimental queries, and that the location of the constrained “Pareto” optimum is very close to the constrained “Pareto” optimum measured from a traditional load-pull (Figure 2-22(a)).

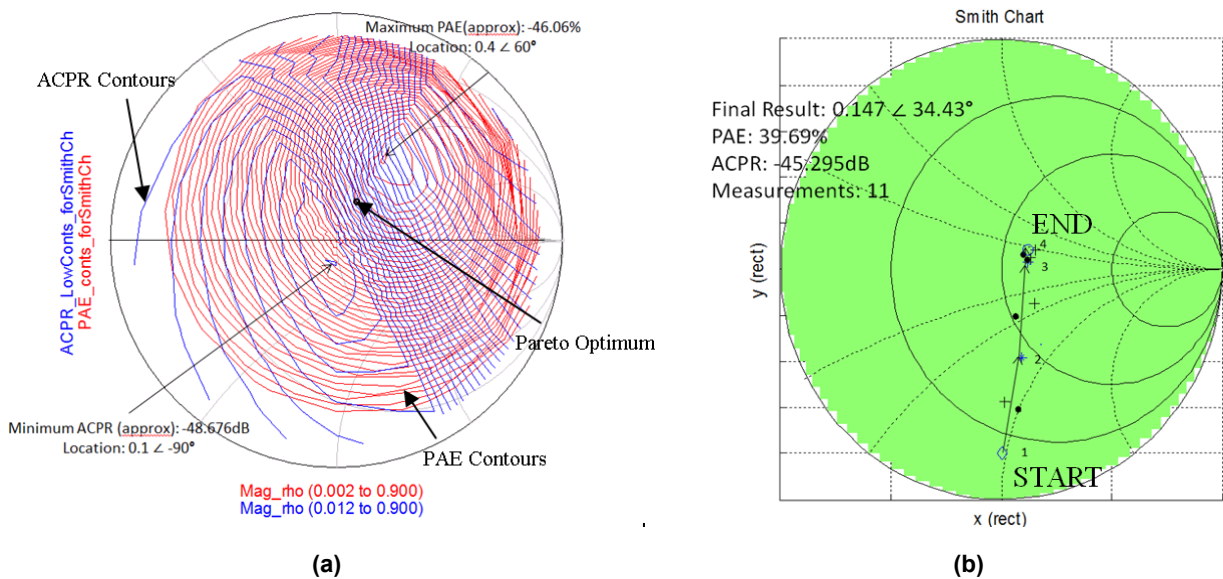

Figure 2-22: Simulated Load-Pull Contours for Modelithics Non-Linear Transistor Model, with the PAE Contours, ACPR Contours, and Constrained “Pareto” Optimum Shown.

Table 2-1 shows a comparison of algorithm simulation results for multiple starting values of Γ_L . The resulting Γ_L locations of the optimum points are all similar, as well as the PAE results. It can be seen that the ACPR values of the resultant optima are all near yet slightly below -45 dBc.

Table 2-1: Load-Reflection Coefficient Optimization Algorithm Simulation Results.

Start Γ_L	End Γ_L	End PAE (%)	End ACPR (dBc)	# Pts.
$0.8 \angle 90^\circ$	$0.383 \angle 94^\circ$	38.25	-45.78	17
$0.8 \angle -90^\circ$	$0.147 \angle 34^\circ$	39.69	-45.30	11
$0.8 \angle 180^\circ$	$0.129 \angle 69^\circ$	38.90	-46.25	14
$0.8 \angle 0^\circ$	$0.153 \angle 43^\circ$	40.56	-45.26	25
0	$0.177 \angle 60^\circ$	40.70	-45.27	11

Figure 2-23 shows measurement results for this algorithm. Figure 2-23(a) shows the results for a traditionally measured load-pull of a Skyworks amplifier, and Figure 2-23(b) shows the results of the search algorithm from a starting point $\Gamma_L = 0.9 \angle -90^\circ$. In Figure 2-23(a), it can be seen that multiple measured values of Γ_L are used (defined by '+' annotations). However, in the case of the intelligent algorithm, only 13 measured values of Γ_L are required to reach the optimum. Table 2-2 shows a comparison of algorithm measurement results for multiple starting values of Γ_L . All results are under the ACPR limit with similar PAE results displayed.

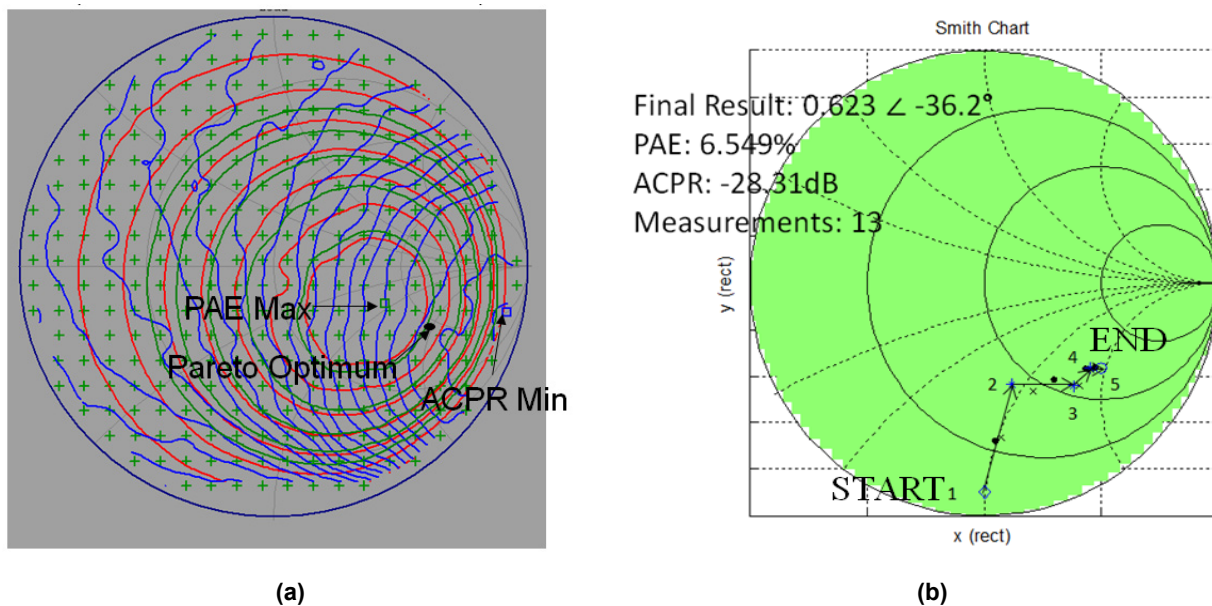

Figure 2-23: Skyworks Amplifier (a) Traditionally Measured Load-Pull Results and (b) Search Algorithm Results from Starting $\Gamma_L = 0.9/-90^\circ$.

Table 2-2: Load-Reflection Coefficient Optimization Algorithm Measurement Results.

Start Γ_L	End Γ_L	End PAE (%)	End ACPR (dBc)	# Pts.
0.9 $\angle -90^\circ$	0.623 $\angle -36.2^\circ$	6.55	-28.31	13
0.9 $\angle 90^\circ$	0.592 $\angle -4.81^\circ$	6.67	-28.30	17
0.9 $\angle 180^\circ$	0.621 $\angle -17.2^\circ$	6.53	-28.28	22
0.9 $\angle 0^\circ$	0.584 $\angle -8.99^\circ$	6.74	-28.32	11
0	0.580 $\angle -17.7^\circ$	6.88	-28.28	13

Table 2-3 provides a comparison of this algorithm’s measurement results with a previous, two-step algorithm our group previously developed as part of this NATO effort [69]. Measurements were performed using both algorithms from identical starting values of Γ_L . The results show that the new algorithm provides a 45 to 50 percent reduction in measurements over our previous algorithm for the cases shown.

Table 2-3: Measurement Comparison of Triangulation Algorithm with Previous Two-Step Algorithm.

Start Γ_L	New Algorithm End PAE (%)	Algorithm from [4] End PAE (%)	New Alg'm # Pts.	Alg'm from [4] # Pts.	% Red.
0.9 $\angle -90^\circ$	6.55	6.59	13	25	48%
0.9 $\angle 90^\circ$	6.67	6.14	17	31	45%
0.9 $\angle 180^\circ$	6.53	6.50	22	40	45%
0.9 $\angle 0^\circ$	6.74	7.11	11	22	50%
0	6.88	6.88	13	25	48%

2.4.2 Load Impedance Optimization Based Directly on PAE and Spectral Mask Compliance

As demonstrated, the initial algorithm for load impedance optimization is based directly on the ACPR. While it is a useful measurement of non-linearity artifacts, most radar regulations do not use ACPR to determine spectral compliance. Instead, spectral masks are used, and transmitted waveforms are required to be at or below spectral mask limitations to be within compliance. As such, optimization based directly on the spectral mask (instead of ACPR) and PAE is likely to be more useful to real-time radar transmitter circuit optimization. The results in this sub-section are taken from a journal manuscript that is presently under review [38].

We have defined a metric for spectral mask compliance, S_m , as follows:

$$S_m = \max(s - m) \tag{2-15}$$

where s is the measured power value of the spectrum in dBm, and m is the spectral mask power in dBm. S_m is the maximum difference between the spectrum and the mask over all measured frequencies.

If $S_m > 0$, then the spectrum is out of compliance with the mask. If $S_m \leq 0$, then the spectrum is in compliance with the mask.

The search process is constructed in a manner similar to the ACPR-based search. Gradients are calculated for PAE and S_m using measurements as shown in Figure 2-20. Figure 2-24 shows the construction of the search vector in cases where the measured spectrum is out of compliance with the mask (Figure 2-23(a), $S_m > 0$) and in compliance with the mask (Figure 2-23(b), $S_m \leq 0$). In this case, \hat{m} is the gradient in the direction of steepest descent for S_m . \hat{b} is the bisector of \hat{m} and \hat{p} . D_b is defined as in equation (2.13), and D_m is defined as follows:

$$D_m = \frac{D_s |S_{m,meas}|}{2 |S_{m,worst}|} \tag{2-16}$$

where $S_{m,meas}$ is the measured value of S_m at the candidate, and $S_{m,worst}$ is the maximum (worst-case) value of S_m encountered during the optimization.

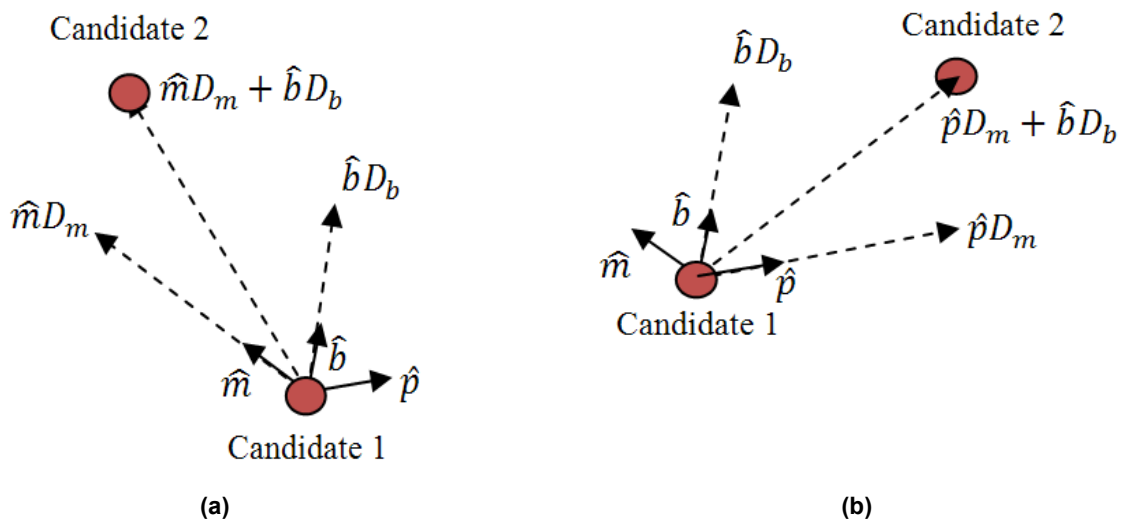

Figure 2-24: Search Vector Construction for: (a) $S_m > 0$ (Out of Compliance) and (b) $S_m \geq 0$ (in Compliance).

Measurement-based testing of the algorithm was performed using the Skyworks amplifier. Figure 2-25 and Table 2-4 show the results of the algorithm from multiple starting Γ_L values. All of the endpoints demonstrate spectral mask compliance ($S_m \leq 0$). All of the searches converge to similar values of PAE and Γ_L with a small number of measurements. Figure 2-26(a) and Figure 2-26(b) show the measured spectrum with the spectral mask for the start and end points, respectively, from the search beginning at $\Gamma_L = 0.9 \angle -90^\circ$. Figure 2-26(a) shows that, at the beginning of the search, the spectrum is out of compliance with the mask, while Figure 2-26(b) shows that the spectrum at the end of the search is within spectral mask requirements.

IMPROVED TRANSMITTER SPECTRAL PURITY

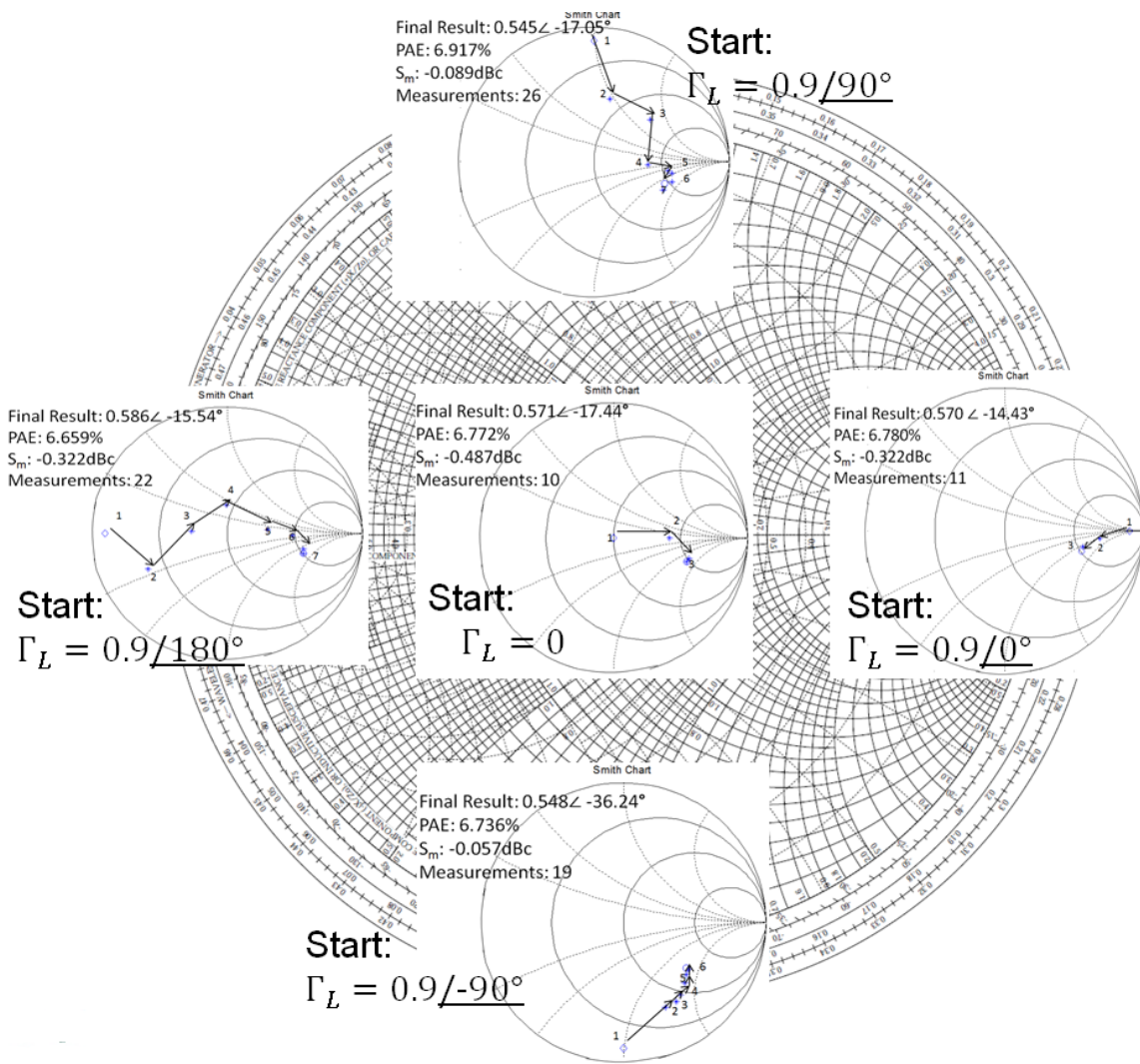

Figure 2-25: Spectral-Mask Based Search Results from Multiple Starting Γ_L Values.

Table 2-4: Results for Spectral-Mask Based Load Impedance Optimization from Multiple Starting Load Reflection Coefficient Values.

Start Γ_L	End Γ_L	End PAE (%)	End S_m (dBc)	# Pts.
$0.9 \angle 0^\circ$	$0.570 \angle -14.43^\circ$	6.780	-0.322	11
$0.9 \angle 90^\circ$	$0.545 \angle -17.05^\circ$	6.917	-0.089	26
$0.9 \angle 180^\circ$	$0.586 \angle -15.54^\circ$	6.659	-0.322	22
$0.9 \angle -90^\circ$	$0.548 \angle -36.24^\circ$	6.736	-0.057	19
0	$0.571 \angle -17.44^\circ$	6.772	-0.487	10

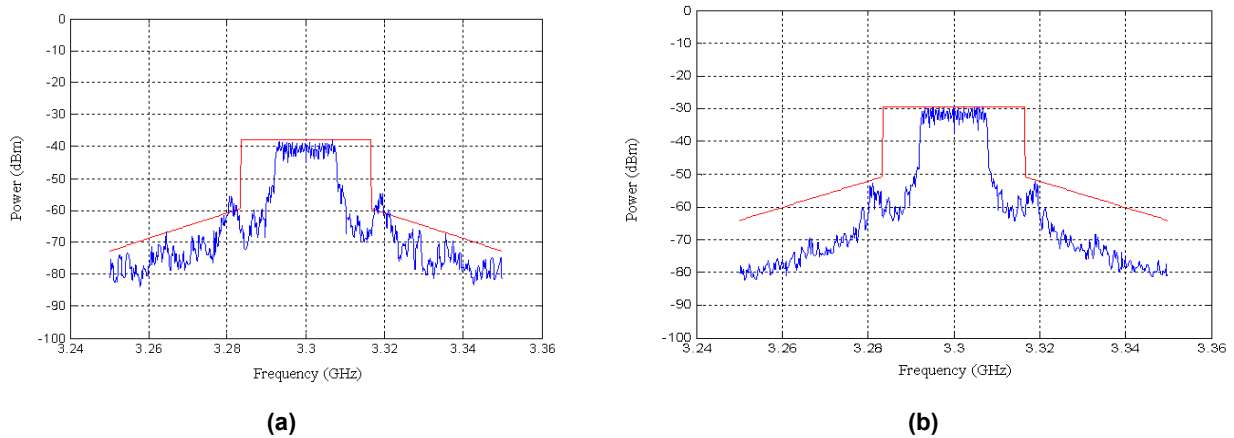

Figure 2-26: Measured Spectra and Spectral Mask at (a) Starting Point $\Gamma_L = 0.9/-90^\circ$ and (b) Search Endpoint $\Gamma_L = 0.548/-36.24^\circ$.

2.4.3 The Smith Tube for Joint Circuit and Waveform Design

The goal of the Baylor research team’s effort is to design a joint circuit and waveform optimization that is feasible for implementation in adaptive radar transmitters. To visualize this problem, a multi-dimensional optimization space is necessary so that optimization with respect to both circuit and waveform parameters can be effectively visualized. Traditional circuit optimization parameters are visualized in the two-dimensional Smith Chart: this is effectively the complex plane of the load reflection coefficient Γ_L . The circuit optimization involves optimizing Γ_L , which means that a single complex variable (two real variables) is used as an optimization parameter. The results in this sub-section were previously presented in an IEEE conference paper [39].

A waveform parameter can be added to the optimization visualization by extending the Smith Chart cylindrically into a third dimension. This extension of the Smith Chart is known as the Smith Tube [9]. In our early work [40], the third dimension of the Smith Tube has been used to represent the bandwidth B of a chirp waveform. The Smith Tube is pictured in Figure 2-27.

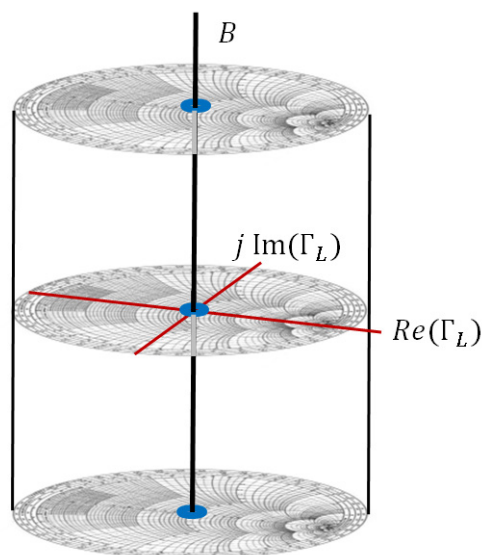

Figure 2-27: The Smith Tube for Joint Circuit and Waveform Optimization.

In previous experiments, we have optimized the radar chirp waveform bandwidth based on the related baseband ambiguity function [20], [15]. We believe there is promise for such optimization to be merged with the circuit optimization using the Smith Tube.

A sample design-based optimization problem applicable to range-resolution radar transmitters is depicted in Figure 2-28. It may be desirable in many cases where range resolution is of importance to maximize the bandwidth of the waveform while meeting requirements on Power-Added Efficiency (PAE) and Adjacent-Channel Power Ratio (ACPR). The problem can be solved by performing load-pull measurements for multiple values of input chirp waveform bandwidth B . From this data, surfaces of equal PAE and ACPR can be plotted throughout the Smith Tube. The highest point in the Smith Tube contained in the intersection of the surfaces representing the limiting PAE and ACPR values is the desired design point. This is the point that provides the largest bandwidth B while meeting PAE and ACPR requirements. This point represents the desired combination of Γ_L and B to be used for the design.

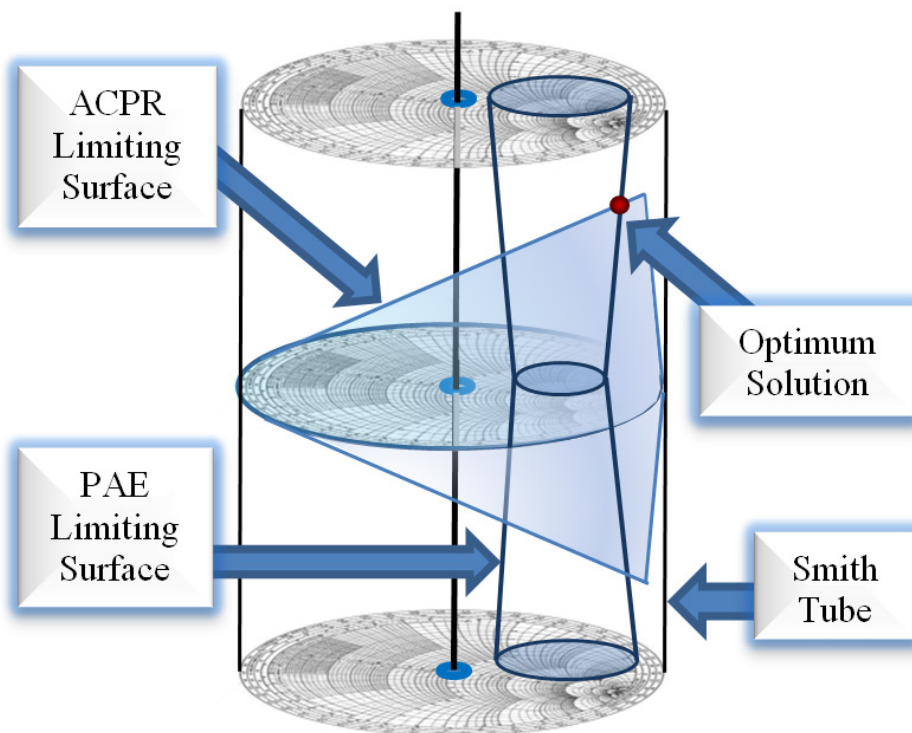

Figure 2-28: Conceptual Depiction of Range-Resolution Optimization Using the Smith Tube.

The PAE surface is expected to be nearly cylindrical, as the output power (a significant component of the PAE) is measured using a broadband power sensor. In practice, some variation with bandwidth is observed, likely due to the variation of the actual impedance over the bandwidth of the chirp. To illustrate the dependence on bandwidth, the maximum PAE and minimum ACPR are plotted from load-pull data taken at multiple bandwidths in Figure 2-29. As expected, the PAE stays relatively constant with bandwidth. However, the ACPR increases with increasing bandwidth. This too matches expectations. As the signal bandwidth begins to widen, the frequencies representing third- and fifth-order intermodulation from in-band content begin to appear in the defined adjacent channel, and more spreading into this defined adjacent channel tends to occur.

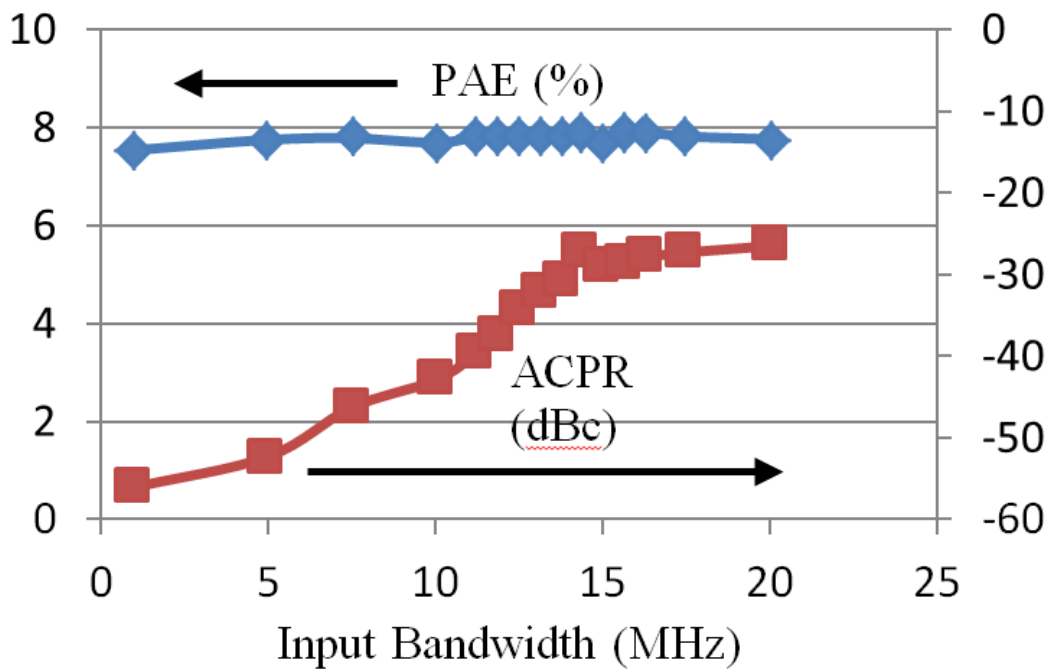
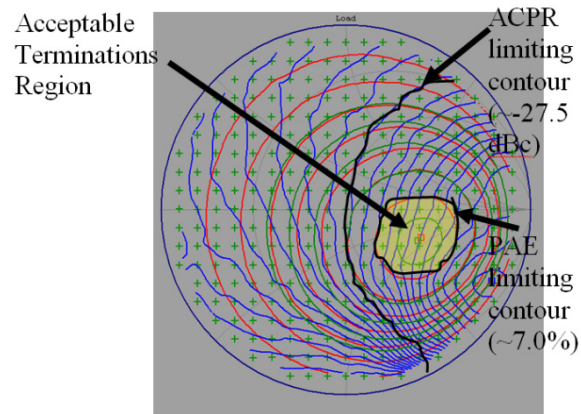

Figure 2-29: Maximum PAE and Minimum ACPR as Measured from Load-Pull Data Taken at Multiple Bandwidth Values for a Skyworks Amplifier.

To demonstrate the design procedure, a design was performed for the Skyworks amplifier. The goal is to find the combination of Γ_L and B providing the largest bandwidth allowing $\text{PAE} \geq 7\%$ and $\text{ACPR} \leq -27.5 \text{ dBc}$. Load-pull measurement data was obtained for chirp excitation waveforms of the following bandwidths: 1, 5, 7.5, 10, 11.25, 11.875, 12.5, 13.125, 13.75, 14.325, 15, 15.625, 16.25, 17.5, and 20 MHz.

Figure 2-30 shows the measured load-pull contours for selected chirp bandwidth values. At each value of bandwidth, the acceptable region of Γ_L choices providing PAE and ACPR values is the intersection of the regions representing $\text{PAE} \geq 7\%$ and $\text{ACPR} \leq -27.5 \text{ dBc}$. It can be seen that this acceptable region in the Smith Chart is smaller as B is increased. The acceptable region is very small for $B = 13.75 \text{ MHz}$, and does not exist for $B = 15 \text{ MHz}$. The optimum point chosen was for the highest value of B measured for which at least one acceptable value of Γ_L can be obtained. The optimum point in the Smith Tube chosen for this design was at $B = 13.75 \text{ MHz}$, $\Gamma_L = 13.75 \text{ MHz}$. This point provides $\text{PAE} = 7.57\%$ and $\text{ACPR} = -28.75 \text{ dBc}$, both within the stated acceptable PAE and ACPR criteria.



(a)

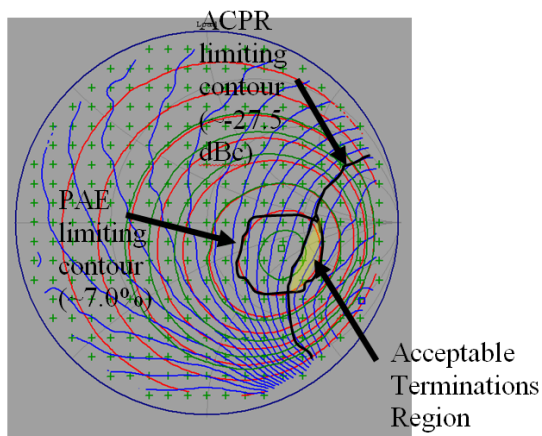

(b)

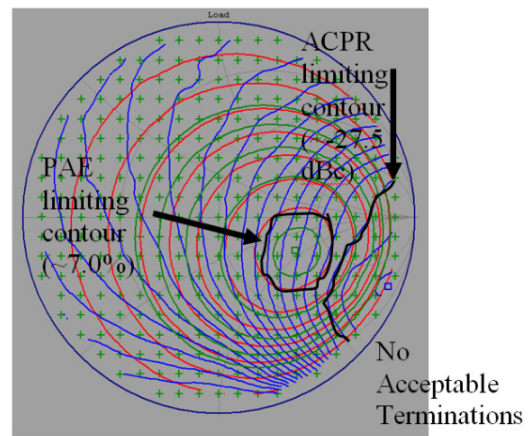

(c)

Figure 2-30: Measured Load-Pull Data for Different Bandwidth Chirp Waveforms: (a) $B = 12.5$ MHz; (b) $B = 13.75$ MHz; (c) $B = 15$ MHz.

Figure 2-31 shows the visualization of this design in the Smith Tube based on measurement data. The optimum solution is the highest intersection between the PAE and ACPR acceptable regions.

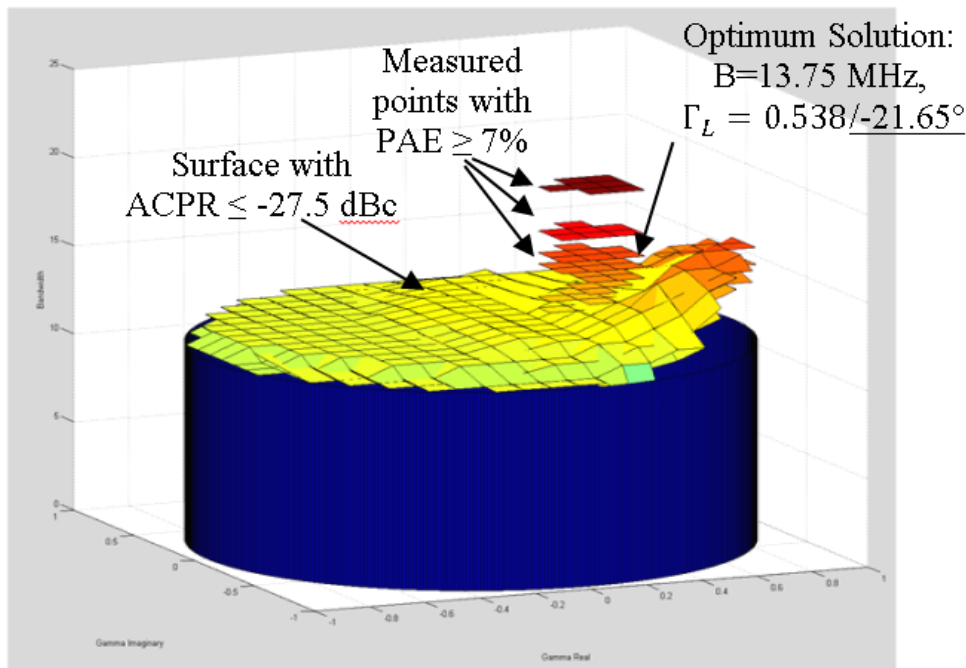

Figure 2-31: Visualization of the Design Solution in the Smith Tube Based on Measured Data.

2.4.4 Next Steps in Joint Circuit and Waveform Optimization for Spectrally Sensitive, Adaptive Radar

The work described continues at Baylor University. Research in the area of intelligent, fast joint circuit and waveform optimization is being performed. Use of the Smith Tube to visualize relevant design problems is being augmented. Upcoming work focuses on the dynamic determination of a spectral mask based on locations of nearby communication nodes and understanding of the ambiguity functions of waveforms for waveform and circuit optimization purposes. The present work is funded by the United States National Science Foundation (Award Number ECCS-1343316).

While excellent progress is being made toward the creation of algorithms for eventual implementation of real-time, joint circuit and waveform optimization in an adaptive or cognitive radar, **significant additional funding is desperately needed to design and test these algorithms into a real radar transmitter front end**. The Baylor research team has identified and constructed collaborations to take the work to this level, but funds are needed. It is recommended that the NATO community identify and prescribe funds for the following activities:

- 1) Identify and accumulate the necessary components to construct a prototype of an adaptive amplifier.
- 2) Use circuit and waveform optimization techniques described herein (and under additional development) to optimize a practically implementable, tunable load network. Candidates for such circuitry include tunable Micro-Electrical Mechanical Systems (MEMS) and varactor technology.
- 3) Design and fabricate an adaptive power amplifier for field testing. Candidates for this approach include Monolithic Microwave Integrated Circuit (MMIC) and hybrid circuit technology. The initial plan is to design a MMIC power amplifier with a tunable MEMS load matching network and fabricate this amplifier through collaboration with the United States Naval Research Laboratory.
- 4) Integrate the designed and constructed MMIC into a radar transmitter platform, such as AN/SPY-1A at the University of Oklahoma, with typical antenna phased array and perform field testing.

While there will be costs associated with continuing this work, it is important that the NATO community realize that this work is **vitaly urgent** to the ability of future radar transmitters to perform needed functions while complying with increasingly stringent spectral requirements. Spectrum management alone will not solve today's spectrum issues. It will require unique and innovative solutions, such as these ideas for reconfigurable radar transmitters, to allow radar to meet spectrum requirements and to thrive in today's dense spectral environment.

As mentioned earlier, the work in this section has been funded in part by a grant from the U.S. National Science Foundation (Award Number ECCS-1343316). Moreover, Agilent Technologies graciously provided the cost-free loan of the Advanced Design System software, and Modelithics donated circuit model libraries through the Modelithics University Program. Finally, collaboration with Lawrence Cohen of the U.S. Naval Research Laboratory has been vital to the success of this work.

Chapter 3 – BETTER RECEIVERS

3.1 INTRODUCTION

The radar receiver's purpose, working in concert with the radar antenna, is to process a desired echo signal in the presence of noise, electromagnetic interference, or clutter. It must isolate the desired signals, and amplify these signals to a level where target information can be detected and displayed to an operator or be converted to digital form for processing by a digital signal processor and a data processor (Figure 3-1 below). While not explicitly discussed in detail in this chapter it is worth mentioning several facts concerning the digital signal and data processors. In modern radars digital signal processing normally performs the following functions:

- 1) Coherent integration;
- 2) Doppler filtering; and
- 3) Pulse compression.

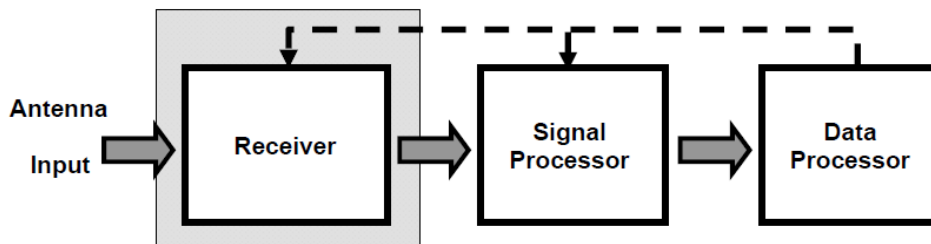

Figure 3-1: Notional Receiver/Processor Hierarchy Diagram.

The automatic data processor which follows the digital signal processor in the signal hierarchy accomplishes:

- 1) Track filtering;
- 2) Establishment of track files; and
- 3) Data association.

The design of a radar receiver will be governed not only by the temporal and spectral characteristics of the waveform, but also by the kinds of noise, interference, and clutter echoes with which the target echo signals must compete.

The goal in the design of modern radar receivers is to push receiver functionality from the analog to the digital domain. Digitizing allows the flexibility of adaptively changing frequency, bandwidth and gain functions to support a variety of modes required of a modern military radar.

3.2 BASIC ANALOG RADAR RECEIVER TOPOLOGY

Most contemporary radars used for defence purposes employ an initial analog type receiver which looks somewhat like that presented in Figure 3-2. The antenna converts the incident electromagnetic energy from target returns as well as clutter and interference, e.g., picowatts/area into picowatts, for amplification and processing by the receiver. A duplexer is a component that isolates and protects the receiver during the transmit interval. During the listening period the duplexer allows received power to flow to the Low-Noise Amplifier (LNA). Not shown is a diode limiter that would be installed between the duplexer and

LNA that would conduct in the presence of high levels of interference protecting the LNA from damage. The LNA is an amplifier with a very low noise factor. Noise enters the receiver through the antenna terminals in concert with the desired signals, and is also generated within the receiver itself. The noise factor is a metric that defines the amount of noise generated by the individual components comprising the receiver. All practical circuits and components have resistance and therefore generate noise. The noise factor of a component, such as an LNA is a measure of the noise produced by a practical component as compared with the noise of an ideal component. The noise factor, F_n describes the amount of noise a component, such as an LNA, generates. Equation (3-1) describes the calculation of noise factor F_n where $N_{in} = kT_0B_n$ with $k = 1.38 \times 10^{-23}$ W/K/Hz (Boltzmann’s constant), $T_0 = 290$ Kelvin (room temperature), B_n = noise bandwidth, N_{out} is the output noise power and G_n is the amplifier’s gain. Because the LNA is at the beginning of the amplifying and processing chain its noise factor dominates the overall noise factor as described by the Friis equation (Eq. 3-2) where F_1 represents the noise factor of the LNA.

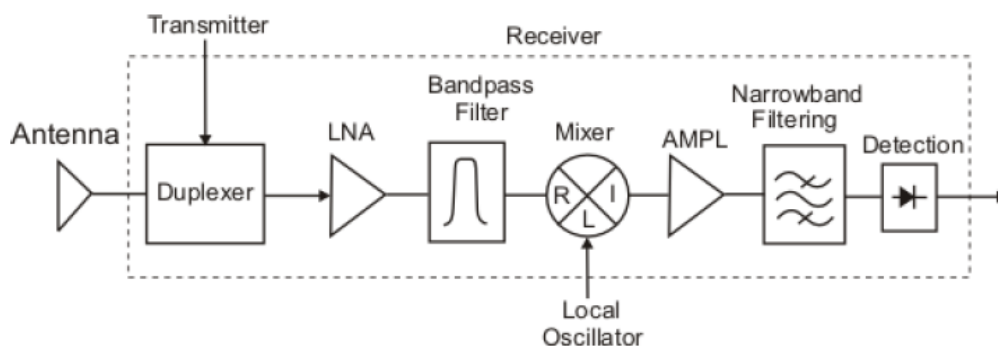

Figure 3-2: Analog Receiver [85].

$$F_n = \frac{\left(\frac{S_{in}}{N_{in}} \right)}{\left(\frac{S_{out}}{N_{out}} \right)} = \frac{1}{G_n} \frac{N_{out}}{N_{in}} \tag{3-1}$$

$$F = F_1 + \frac{F_2}{G_1} + \frac{F_3}{G_1 G_2} + \dots \tag{3-2}$$

Noise factors, F , when describing the noise contributions of components such LNAs are converted to noise figures ($10\log_{10} F$) and are designated in decibels for ease in computing gains and losses in receiver and transmitter chains applying addition and subtraction. An adjustable bandpass filter [60], [61] could be installed prior to the LNA in Figure 3-2 to attenuate undesirable spectral products (in-band and out-of-band) that could result in saturating the LNA.

3.3 DYNAMIC RANGE

The LNA dynamic range is the excursion in dB from the noise threshold plus the noise figure ($kT_0B + F$) dB to the 1.0 dB compression point. Target returns can vary over a large dynamic range because of differences in Radar Cross-Section (RCS) involving small to large targets and due to the $1/R^4$ decrease in the power density as a function of range, R . In fact, should the LNA be driven into saturation beyond the 1.0 dB compression point, in-band third-order intermodulation products can be generated which could mask weak targets. Figure 3-3 shows an output versus input plot for an LNA. The LNA linear range is where the output

will increase by a constant increment in dB for a given dB increase in the input, forming a line with a 1:1 slope. A second-order and third-order line with a 2:1 and 3:1 slope respectively are extrapolated at the input point where the second and third intermodulation products begin to appear in the output. These lines are continued to their respective points where they intersect the linear output line above the 1.0 dB compression point. Since the third-order intermodulation products are important due to their ability to contribute in-band interference, a rule-of-thumb is used which states that the third-order intercept point is approximately 10 dB above the 1.0 dB compression point. The LNA linear range is where the output will increase by a constant increment in dB for a given dB increase in the input, forming a line with a 1:1 slope. A second-order and third-order line with 2:1 and 3:1 slopes respectively are extrapolated at the input point where the second and third intermodulation products begin to appear in the output. These lines are continued to their respective points where they intersect the linear output line above the 1.0 dB compression point. Since the third-order intermodulation products are important due to their ability to contribute significant in-band interference a rule-of-thumb is used that states that the third-order intercept point is approximately 10 dB above the 1.0 dB compression point.

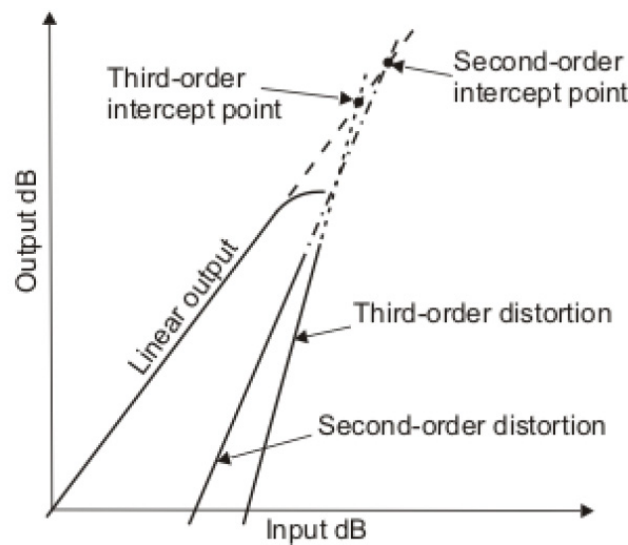

Figure 3-3: LNA Distortion versus Input Power [85].

3.4 MIXERS AND DOWNCONVERSION

The majority of radars must downconvert the RF signals to a lower intermediate frequency for detection and processing. The mixer downconverts in frequency the amplified signal, f_s , to an Intermediate Frequency (IF), f_{if} through a multiplication with a local oscillator signal. The frequency multiplication process produces sum and difference second-order intermodulation products ($f_{lo} \pm f_s$) where $f_{lo} - f_s$ is designated f_{if} (IF). The IF signal is amplified and goes through bandpass filtering in order to remove harmonic and third-order intermodulation products that may have been produced during the mixing process. Figure 3-4 shows an example of a single downconversion from an 11 GHz RF (X-band) to a 200 MHz IF. The final IF frequency must be low enough for the input frequency to the logarithmic amplifier for downconversion to video or to enable conversion of the IF signal to digital format by an analog to digital converter.

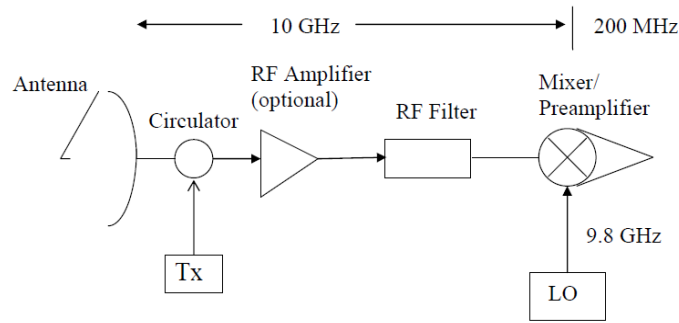

Figure 3-4: Single Downconversion [85].

3.5 ANALOG COHERENT DETECTION

More advanced defence radars employ coherent processing to enable the radar to accomplish tasks such as:

- 1) Moving Target Indication (MTI) to discriminate between stationary clutter such as land masses and moving targets;
- 2) Doppler processing to measure the velocity of moving targets such as aircraft; and
- 3) Synthetic Aperture Radar (SAR) processing for mapping features such land masses and distinguishing potential targets.

Coherent detection, in addition to amplitude, determines the phase of the receive signal relative to that of the transmit signal. The phase of the receive signal can be obtained in coherent radars by converting the IF signal to In-phase (I) and Quadrature phase (Q) video, such as shown in Figure 3-5. The IF signal instead of going to a diode detector (Figure 3-4) is routed into 2 paths through a 3 dB splitter, each of the 2 paths inputted to individual mixers. A Coherent local Oscillator (COHO) is sent to a 90-degree quadrature hybrid where 2 COHO signals with a 90-degree phase relationship to one another are each sent to the 2 mixers. In order to maintain 90-degree phase coherency between the 2 COHO signals, phase trimmers (usually adjustable capacitances) are in the path COHO paths to the mixers. In fact amplitude and phase coherency is critical in order to avoid images in the Doppler domain which could result in false targets or cause interference to the detection of desired targets. The in-phase and quadrature components $I = \cos\theta$ and $Q = \sin\theta$ are generated in the upper and lower double-balanced mixers respectively. These I and Q components are each inputted to low pass filters in order to extract the lower frequency video components. The I and Q digital components are then amplified by video amplifiers to the required voltage levels for application to analog to digital converters.

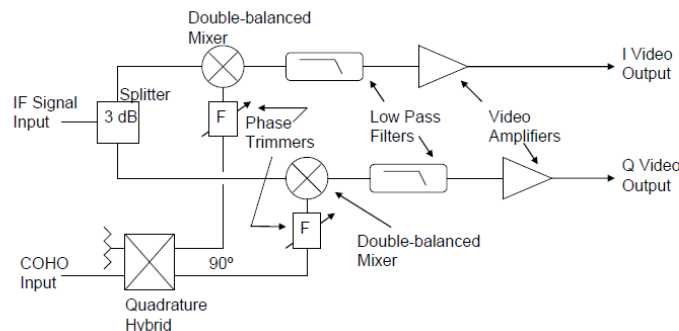

Figure 3-5: Analog Coherent I/Q Downconverter [85].

3.6 DIGITAL COHERENT DETECTION

Direct digital I and Q sampling is being employed in many new radar applications to obtain coherent, I and Q video samples of the IF signal (Figure 3-6). The primary enabler for this is advances in the sampling speeds of Analog-to-Digital Converters (ADCs). The main advantage of direct digital sampling is that it eliminates the errors associated with imperfect quadrature and the amplitude and phase matching of the I and Q channels.

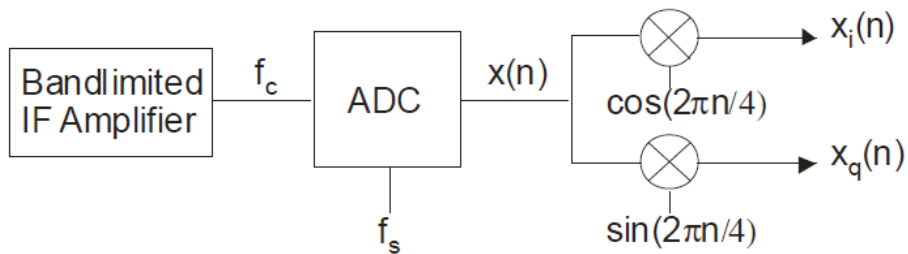

Figure 3-6: Digital Coherent I/Q Down Conversion [85].

Normally the sampling frequency f_s needs to be chosen to be four times the IF center frequency (f_0), but in most cases this would require an extremely high sample frequency. However, since the IF signal is normally bandlimited by the IF amplifier, the sampling can be performed at a lower frequency or the bandwidth of the IF amplifier. The Nyquist theorem states that **“any signal can be represented by a set of equally-spaced discrete samples provided that the sampling frequency is at least twice the bandwidth of the signal”**. For example, suppose the IF center frequency is 60 MHz, and the IF bandwidth is less than 10 MHz. Instead of sampling the IF at 240 MHz, the sampling frequency could be chosen to be 40 MHz. The direct digital implementation is becoming increasingly popular due to the continuing advances in Analog-to-Digital Converters (ADCs) with high sampling speeds and increased bit resolutions. Dynamic range in a digital receiver (prior to processing gain in the signal processor) is limited by the dynamic range of the ADC. Normally, the noise level into the receiver is set to be about 2 Least Significant Bits (LSBs). This is due to the fact that signals from small targets at far ranges are often buried in the noise, and unless the gain is set so that the noise gets digitized, the follow-on signal processor will not be able to integrate the signal to improve the signal-to-noise ratio of target returns. It is also critical to prevent the maximum received signal from exceeding the full-scale value of the ADC, with about 1 dB of headroom maintained on clutter and targets to prevent ADC saturation effects.

The ADC digitizes the bandlimited IF signal into digital samples. Thus the digital mixer working with the digital oscillator samples ($\cos(2\pi n/4)$ and $\sin(2\pi n/4)$) downconverts these digital I and Q samples with the Q samples shifted in phase 90 degrees with respect to the I samples. An alternative way of generating the real and imaginary parts of a signal is through the use of a Hilbert transformer, as shown in Figure 3-7.

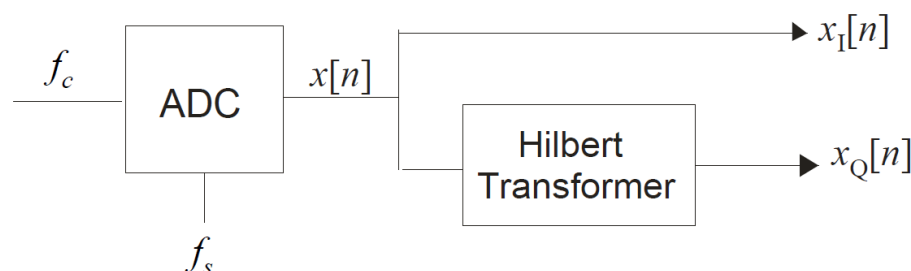

Figure 3-7: Hilbert Transform Computation of Real and Imaginary Signal Components [85].

BETTER RECEIVERS

The real and imaginary components, X_I and X_Q respectively, can then be processed in a Digital Signal Processor (DSP) which can respond adaptively to changes in the target, clutter or interference environment. DSP can facilitate for example the computation of:

- 1) Finite Impulse Response (FIR) bandpass filters to remove any out-of-band spectral components;
- 2) FIR band stop filters to attenuate in-band interfering spectral components;
- 3) Magnitude and phase of target returns with respect to a transmit reference promoting coherent integration for detection of targets above noise, interference and jamming; and
- 4) Doppler filters for the determination of target radial velocity and minimizing the impact of clutter.

Chapter 4 – PASSIVE BISTATIC RADAR

4.1 BACKGROUND

Passive Bistatic Radar (PBR) may be defined as a radar which uses as its illumination source a broadcast, communications or radio navigation transmission rather than a dedicated radar transmitter.

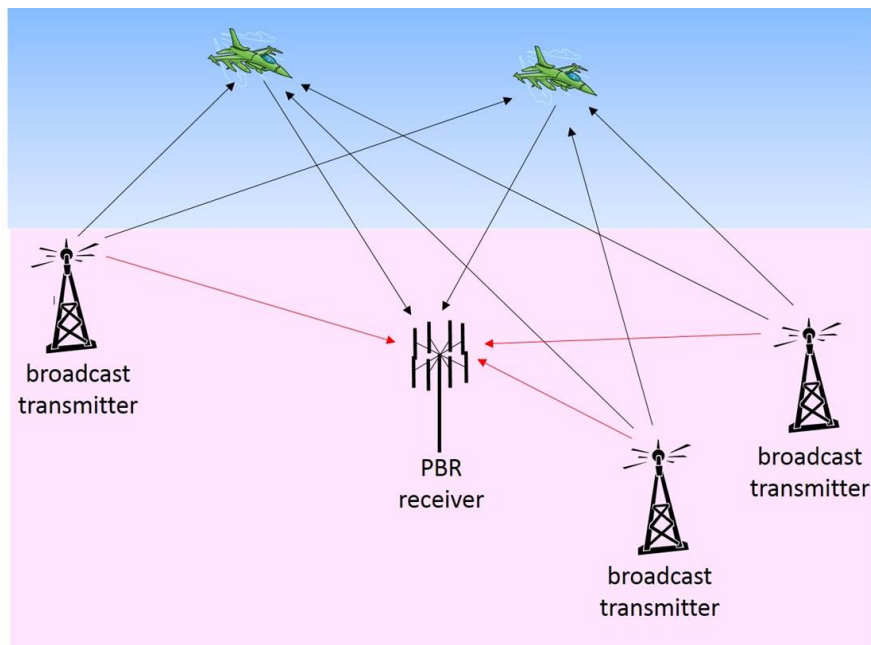

Figure 4-1: Schematic of Passive Bistatic Radar.

There are various other names, including passive radar, Passive Coherent Location (PCL), Passive Covert Radar (PCR), parasitic radar. A discussion in the book *Advances in Bistatic Radar* [100] concludes that none of these terms is quite perfect, but that passive bistatic radar is the best of the bunch. This, or just passive radar, seem to be most frequently used at present.

The techniques date back to at least the 1980s [45], [57]. Most initial work used FM radio or analogue TV transmissions, and it was soon realized that such waveforms are by no means perfect as radar signals. Furthermore, significant signal processing effort is required to suppress the strong direct signal at the receiver [46], [5].

It is notable that research into PBR has received substantial NATO support in recent decades, which has been instrumental in allowing the technology and techniques reach the present level of maturity.

The techniques have some obvious advantages:

- Such illuminators of opportunity are often high-power and are usually sited to give broad coverage.
- They allow parts of the spectrum (particularly VHF and UHF) to be used that are not normally available for radar use. Such frequencies may be beneficial in detecting stealthy targets, since the wavelength is of the same order as the physical dimensions of the target, and forward scatter gives a relatively broad angular scatter.
- The radar is essentially completely covert, especially if the receive antennas are inconspicuous.

- Since the transmitter is already provided – and crucially for the subject of this report – the radar requires no additional spectrum. For this reason the technique has been termed ‘Green Radar’.
- For the same reason, the cost of such systems can potentially be low.
- No transmitting licence is needed.

These advantages have made PBR a very suitable subject for investigation by University groups, and many systems have been built and many papers published. However, there are also some significant disadvantages:

- The waveforms of such illuminators are not optimized for radar purposes, so care has to be used to select the right waveforms and to process them in the optimum way [46].
- The waveforms are usually continuous (i.e., a duty cycle of 100%), so significant processing has to be used to suppress the direct signal and multi-path in order to detect weak target echoes [48].
- For analogue signals, the ambiguity function (resolution in range and in Doppler) depends on the instantaneous modulation, and some kinds of modulation are better than others. Digital modulation does not suffer from these problems, so may be preferred.
- As with all bistatic radars, the resolution in range and Doppler is poor for targets on or close to the bistatic baseline [62], [96].

These latter constraints mean that reliable tracking of targets is difficult, and therefore that PBR has not so far been attractive in real-world applications. There is recent evidence, though, that these problems are being solved [32], by a combination of multiple types of illuminator and intelligent tracking algorithms. A recent defence business report has estimated that the market for PBR over the next decade will be worth over \$10 billion [4], and this perspective has credibility not only because several applications have been identified where PBR may have a significant part to play – of which the spectrum congestion problem is one of the most significant – but also because several commercial companies (Thales, SELEX-SI, Airbus Space and Defence and several others) have built and demonstrated PBR systems.



Figure 4-2: The Antenna Array of the Passive Radar Demonstrator Produced by Airbus Space and Defence.

In addition, the widespread adoption of digital broadcast and communications signals has had a substantial positive effect on PBR development. Such signals are more noise-like and hence have more favourable ambiguity function properties than analogue modulation formats [46], [5], [79].

Several of the digital modulation formats are based on Orthogonal Frequency Division Multiplex (OFDM) in which the digital bit stream is multiplexed into a number of parallel streams, so that the bit length in each individual stream is stretched by a factor equal to the number of parallel streams. The bit length is now much greater than the maximum delay spread of the multi-path, so the multi-path has relatively little effect. The parallel data streams are modulated onto a set of sub-carriers, spaced in frequency such that the nulls of the $(\sin x)/x$ modulated spectrum of one sub-carrier correspond to the carrier frequencies of all of the others (Figure 4-3), in other words, that they are orthogonal to each other. The sub-carrier spacing in frequency required to achieve this is $1/\tau$, where τ is the bit length of the expanded bit stream. The signal, consisting of the modulated simultaneous sub-carriers, is transmitted over the channel. In the receiver each sub-carrier is individually demodulated, then the original data stream is reconstituted by de-multiplexing.

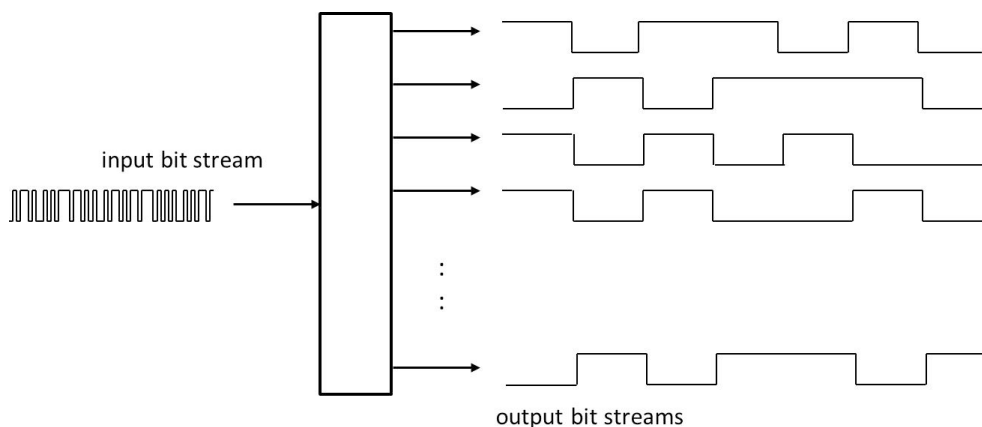

Figure 4-3: OFDM: Multiplexing of the Digital Bit Stream into Multiple Parallel Streams. The bit length of the output bit streams is now much greater than the maximum delay spread of the multi-path.

Like many of today's digital communications waveforms, the LTE waveform is carrier modulated digital data transmitted on sub-carriers arranged as OFDM. OFDM was considered in the 1990s for 3G systems but the more mature Wideband Code Division Multiple Access (WCDMA) was chosen instead. Currently OFDM is widely used in systems such as 802.11 (WiFi), 802.16 (WiMAX) and DAB/DVB broadcasting. Its widest use will soon be in the 4th generation mobile systems based on LTE. These systems started being deployed worldwide in 2012 and are spreading widely. LTE offers data and voice services with downlink data rates up to 100 Mbit/s. The LTE base channel is defined according to channel bandwidths ranging from 1.4 to 20 MHz, divided across a number of OFDM sub-carriers ranging from 72 to 1320. LTE may operate across several frequency bands; 32 bands are defined by the standardization body 3GPP [1] with frequencies ranging from 729 MHz to 3.8 GHz. Operators are allocated specific spectrum bands depending on licensing and bandwidth requirements, with widths that are multiples of 5 MHz for example in the UK operators are allocated bands of 5, 10, 15, 20, 25 and 35 MHz [77]. LTE uses various modulation formats depending on the type of information transmitted and the quality of the wireless channel with QPSK, 16 QAM and 64 QAM defined in the standard [27].

The multiple access scheme of LTE is based on OFDM and termed OFDMA. Users are allocated bandwidth according to demand and traffic loading in a cell. The basic unit of allocation in LTE is termed the LTE Resource Block (RB) and this is based on 1 ms repeating sub-frame divided into two 0.5 ms slots. Each contains 12 sub-carriers with 15 kHz fixed spacing and either 6 or 7 OFDM symbols (depending on

the length of the cyclic prefix used); a single sub-carrier and one OFDM symbol define what is termed Resource Element (RE) which is the smallest information unit of LTE [1], [27]. Therefore, an LTE time domain signal is based on the aggregation of sub-frames into 10 ms frames.

An illustration of an LTE frame and resource block is given in Figure 4-4. To facilitate channel estimation and to transmit control signals, pilots, synchronization and control channels are sent periodically, thus resulting in cyclostationary features. The cyclostationarity of OFDM and of the LTE downlink transmission has been studied and the associated signature have been analysed in different environments (see for example [94] and [3]). The cyclostationarity features influence the overall signal time-frequency characteristics and their efficacy for use in radar applications. A matter worthy of investigation is how to modify such features through appropriate resource block mapping and judicious adjustments of periodic pilot sub-carriers (reference signals in LTE terminology) and cyclic prefix arrangement. Although the signal time and frequency characteristics are standardised, there may be some room for adjustment. For example, LTE allows for short and extended cyclic prefix. Additionally, within the LTE frame, there are some unused resource elements that may be “filled” with specific patterns to set desirable passive radar properties. Furthermore, the wireless channel characteristics would have major influence on received and reflected signal spectra. Therefore, our work aims to investigate potential modifications of LTE signals to alter their signatures.

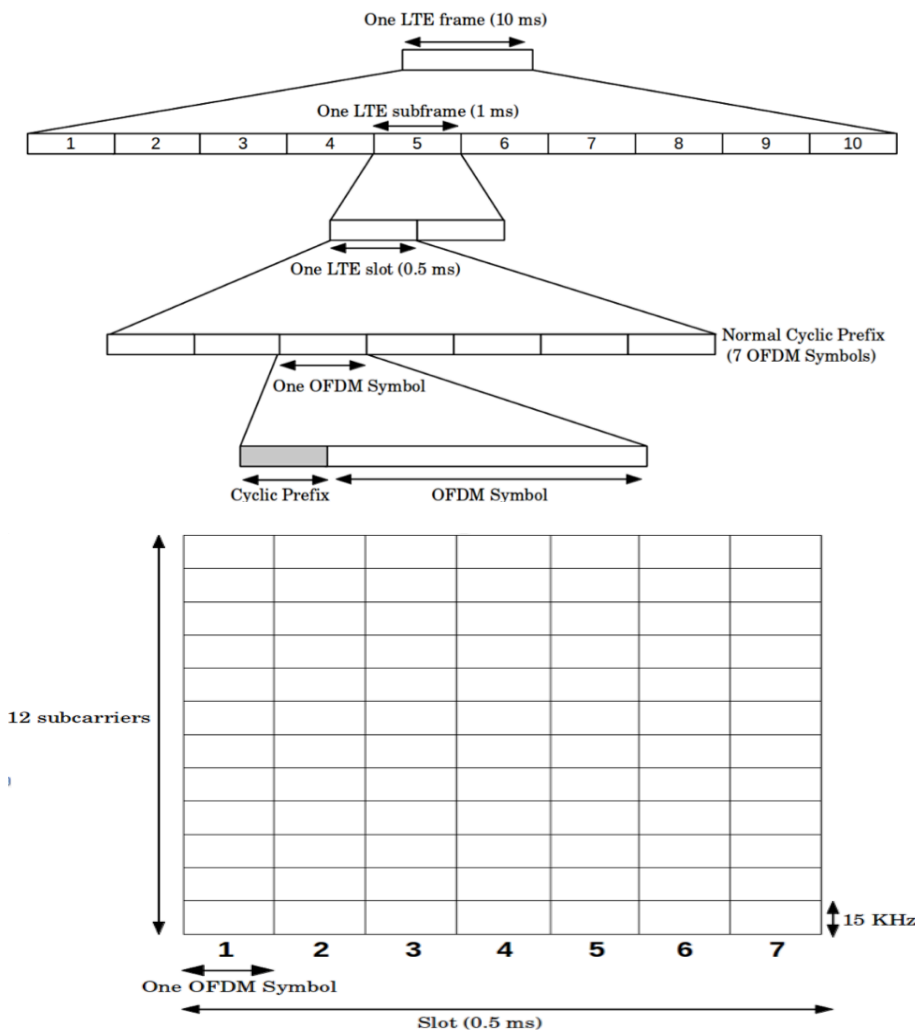

Figure 4-4: LTE Time Domain Frames and a Single Resource Block.

Figure 4-5 shows a resource grid (top) and spectrum (bottom) of a 1.4 MHz LTE signal having six resource blocks (i.e., 72 sub-carriers) and with a simulation period of 10 ms (i.e., simulating a full radio frame comprising 10-1 ms sub-frames indicated by the 140 OFDM symbols on the x-axis).

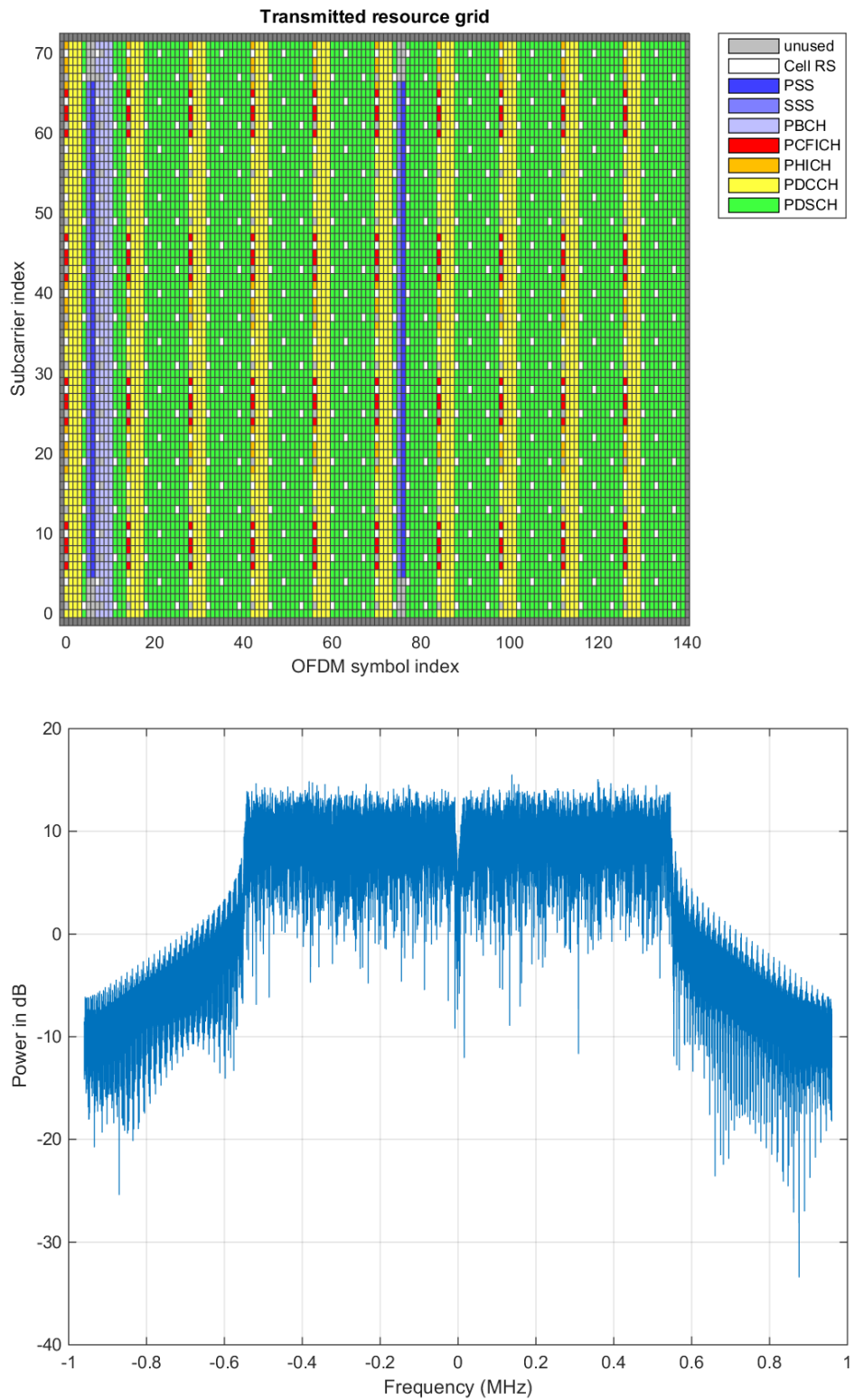

Figure 4-5: Resource Grid (Top) and Spectrum of a 1.4 MHz LTE Signal (Bottom).

Figure 4-6 shows the ambiguity function of the LTE signal of Figure 4-5 with the normal cyclic prefix (left) and extended cyclic prefix (right). It can be seen that both have a single narrow peak with a flat sidelobe structure at about -40 dB below the peak, but the difference between them is in the form of the periodic sidelobes in delay.

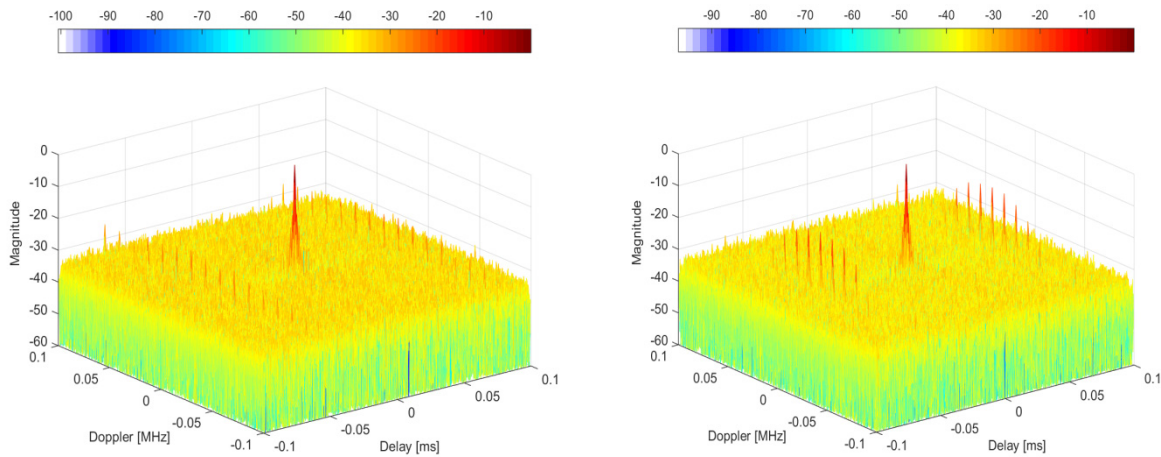

Figure 4-6: Ambiguity Function of LTE Signal of Figure 4-5: Normal Cyclic Prefix (Left) and Extended (Right).

4.2 COMMENSAL RADAR

Taking this further, it may also be desirable in future to design the signals of PBR illuminators so that they not only fulfil their primary function but also have favourable waveform properties for radar purposes. This has been termed ‘commensal radar’ – literally ‘at the same table’ – by Professor Mike Inggs of the University of Cape Town, and is an example of the sort of approaches that will be necessary as the spectrum problem becomes worse. Several authors have looked at the LTE modulation format and concluded that this is a promising approach [87], [88], [33], [47]. The results of Figure 4-6 show that there are degrees of freedom in the design of the LTE signal that may be exploited to optimise the performance as a radar signals. It is recommended that this approach should be studied carefully, since the potential benefits are substantial.

The converse problem, of trying to design a broadcast or communications waveform so that it is impossible, or at least difficult, to exploit as a PBR illuminator, is also worthy of study.

4.3 VERTICAL-PLANE COVERAGE

The performance of a passive radar system depends not only on the waveform, but also on the coverage of the illuminating sources. The coverage of broadcast and communications transmitters will be optimized according to the required services, and the transmitters will frequently be sited on hilltops or on tall buildings. The horizontal-plane coverage is often omnidirectional, though for some cell phone base stations it may be arranged in 120° sectors. The vertical-plane coverage will usually be optimized so as to avoid wasting power above the horizontal, and in some cases the beams may be tilted downwards by a degree or so.

Examples have been published of measured vertical-plane field strength patterns of typical PBR transmitters (VHF FM and DVB-T) [70], [78]. These can be replotted in a more meaningful form (Figure 4-7) to show the reduction in power density illuminating a target as a function of the sine of the elevation angle. It can be seen that the antennas of the VHF FM transmitters have relatively high sidelobes, but the array of the DVB-T transmitter allows greater control of the radiation pattern and hence lower sidelobes.

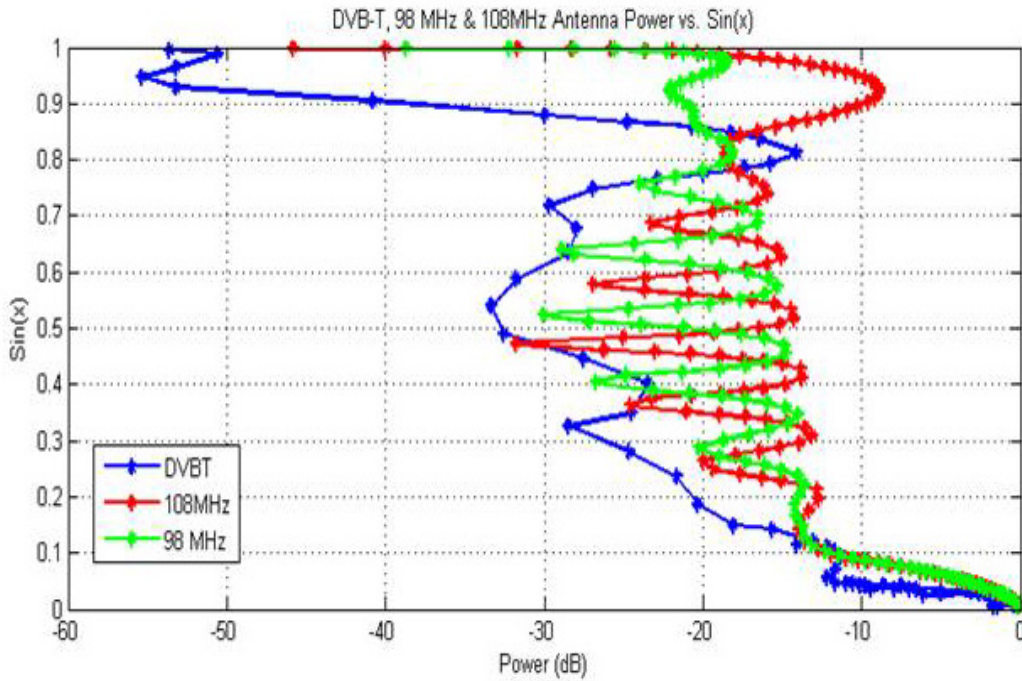

Figure 4-7: Measured Vertical-Plane Radiation Patterns of BBC VHF FM Radio Transmitter at 98 MHz (Green), 108 MHz (Red) and 8-Bay DVB-T Transmitter (Blue).

Taking the radar equation for passive radar in the form:

$$\frac{S}{N} = \frac{P_t G_t \lambda^2 \sigma_b G_p}{(4\pi)^3 R_T^2 R_R^2 k T_0 B F L} \tag{4-1}$$

and rearranging:

$$R_{R\max} = \sqrt{\frac{P_t G_t \lambda^2 \sigma_b G_p}{(4\pi)^3 R_T^2 (S/N)_{\min} k T_0 B F L}} \tag{4-2}$$

shows that for every 10 dB reduction in $P_t G_t$ the maximum detection range R_R for a given target is reduced by a factor of $3.3\times$ (Figure 4-8). Even at the peaks of the elevation-plane lobes the effect is significant, but in the nulls in between the lobes it is even more so.

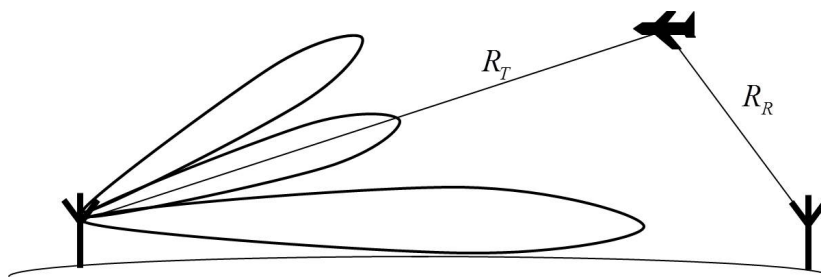

Figure 4-8: The Effect on Detection Range of the Elevation-Plane Pattern of the Source Can Be Substantial.

This means that, for the detection and tracking of air targets, the vertical-plane coverage of illuminators may well be a limiting factor. Commensal radar should be thought of not just in terms of the waveform, but also in terms of coverage, and if such transmissions are to be used both for broadcast/communications and as radar illuminators, the antenna radiation patterns should be tailored accordingly. This applies in the azimuth plane as well as in elevation.

4.4 CONCLUSIONS AND RECOMMENDATIONS

- Developments in the past five years in passive bistatic radar mark a change in the maturity of the subject. Modern systems exploit multiple kinds of transmissions, and achieve much greater coverage and reliability than previously. This means that such systems are now seriously being considered for applications such as air traffic control, 'gap filling' in the coverage of conventional radars, and will have their part to play in addressing the spectrum congestion problem.
- Commensal radar represents an important set of ideas, and should continue to be pursued, as well as the converse problem of trying to design a broadcast or communications waveform so that it is impossible, or at least difficult, to exploit as a PBR illuminator.
- The radiation patterns, and hence the coverage of transmitters, have a substantial effect on their utility as PBR illuminators. Many such sources have vertical-plane radiation patterns which point downwards by a small angle (a degree or two) and which fall off significantly above the horizontal. This results in a substantial loss in coverage in illuminating air targets. If such transmissions are to be used both for broadcast/communications and as radar illuminators, the antenna radiation patterns should be tailored accordingly. This applies in the azimuth plane as well as in elevation.

Chapter 5 – COGNITIVE TECHNIQUES

5.1 INTRODUCTION

Cognitive radar is the name given to a set of techniques in which a radar exhibits intelligence, in some way dynamically adapting its operation according to the information derived from the target scene. The concept comes originally from cognitive radio, in which the frequency used for a communications link is allocated on the basis of sensing the prevailing spectrum occupancy and dynamically choosing a channel for which there will be minimum interference. The applicability to the spectrum problem is obvious.

The notion of cognitive radar can be viewed from two different perspectives:

- As the evolution of bio-inspired control systems to higher level decision-making [52], [53]; or
- As the natural out-growth of knowledge-aided sensor signal processing [49].

Regardless of its roots, in the most general sense cognitive radar is essentially the application of Bayesian learning, through the use of prior knowledge and feedback, to facilitate the development of autonomous decision-making within the radar.

If prior knowledge of the spectral environment exists, it can also be exploited. This approach has enabled cognitive radio to make great strides in recent years. However, cognitive radio has tended to concentrate on radio communication rather than considering the problem in its entirety. A more comprehensive approach would be to map out spectrum usage in terms of spectral, temporal and spatial occupancy of all emitters and exploit this total “spectral landscape” in cognitive type approaches. This perspective would enable cognitive approaches to embrace all emitters in an intelligent fashion. For example, most radar systems scan at a rate of less than one rotation per second. Most power is concentrated in the main beam whose width may only be a few degrees. Thus at any one time the vast majority of the swept volume (typically 90%) is not being used by the radar. As this operation is fully determinable in advance there is considerable opportunity for further improving spectrum usage and possibly spectrum sharing. This form of approach clearly offers efficiency gains in spectrum use without sacrificing performance, thus making it an attractive topic of future study.

Existing radar procedures such as automated frequency agility to avoid other spectral users and dynamic time-division resource allocation to enable different sensing (and possibly other) modes to share the same antenna [96] can be considered as early examples of cognitive systems. However, on-going research is also exploring more radical modifications such as by leveraging the burgeoning work in waveform diversity to enable the radar to design waveforms “on the fly” according to the observed spectral environment and mission requirements (e.g., [10], [80], [44]) through the use of complex feedback mechanisms and automated decision making. In other words, viewing active sensing as a question & answer exercise, how can we enable the radar to select the best questions (i.e., waveforms) so as to obtain the best answers (given the spectral usage constraints) in real time?

Besides the sensor-centric area of waveform diversity, cognitive radar research is also building from previous work in cognitive psychology and artificial intelligence to mimic our own attributes of learning, memory, attention, and intelligence [54], all with the goal of making the radar “smarter”. Compared to the relative ease with which many animals can sense and interact with their environments, it is clear that we are only just beginning to realize the potential of artificial cognitive sensor systems, though continued research is necessary to quantify the likely gains that could be accrued.

5.2 COGNITION

Although a significant number of papers have been published, there is no clear agreement on a definition of Cognitive radar. Haykin [53] is keen to emphasise the *Perception-Action Cycle* (Figure 5-1) and that a

cognitive radar possesses memory, which is updated by the information gained by the radar from the target scene. Another important criterion is stated to be that the radar should dynamically adapt its transmitted waveform in response to its perception of the target scene.

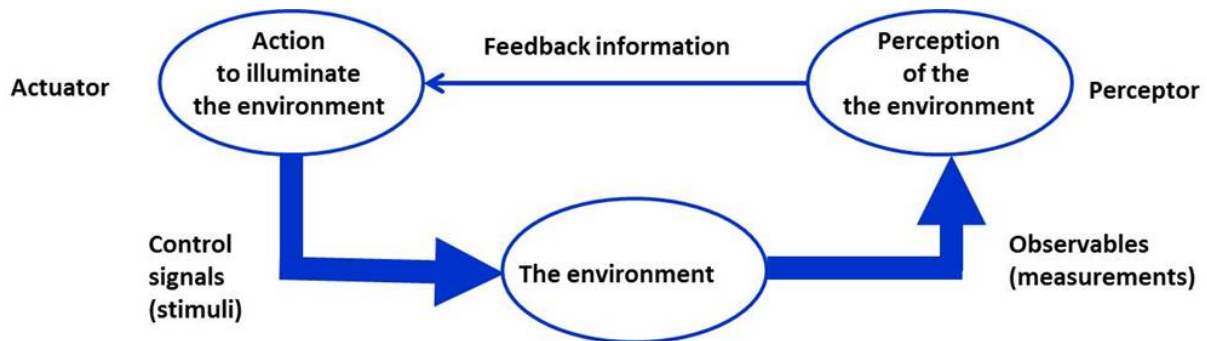

Figure 5-1: The Perception – Action Cycle of Cognitive Radar [53].

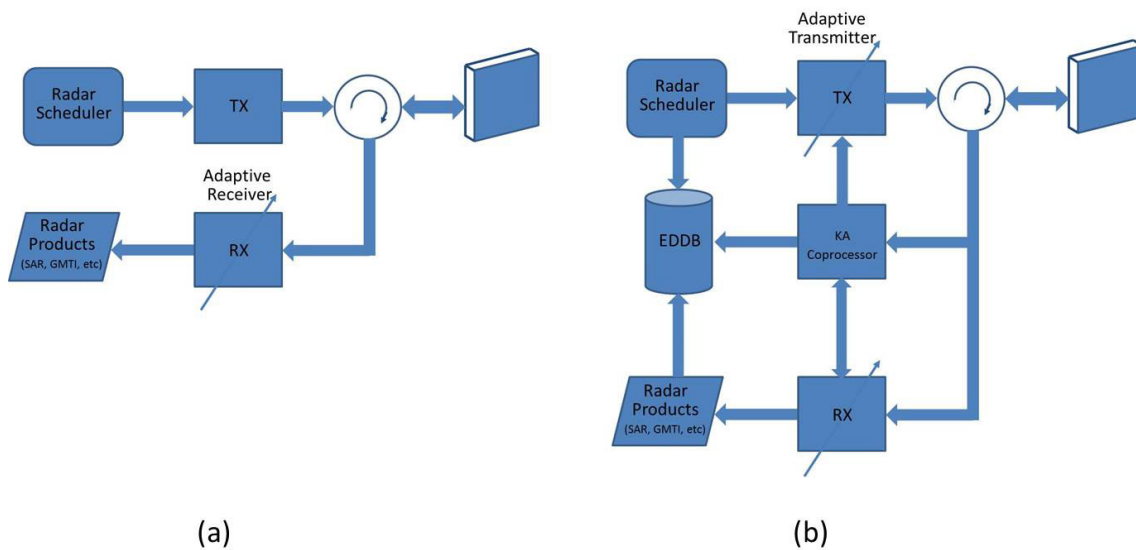

Figure 5-2: (a) Conventional Adaptive Radar; (b) Cognitive Radar [49].

It is possible to test some of the well-established radar signal processing techniques against these criteria to see to what extent they might be regarded as cognitive. Some, such as adaptive antenna arrays and CFAR detection do not meet the criterion of adapting the transmitted waveform so cannot be considered to be cognitive. The way in which an HF OTH radar dynamically selects its frequency and its waveform in response to the prevailing spectrum occupancy and ionospheric conditions might well be regarded as cognitive, as might the waveform selection of an airborne UWB SAR such as CARABAS [28].

At the other extreme, video recordings of a bat’s pursuit of its insect prey [97] show how the bat dynamically alters the form of its (acoustic) transmitted signal during the different phases of the pursuit and quite clearly does demonstrate cognitive behaviour.

We might ask, though, whether any processing scheme that is purely rule-based – in other words, which would always produce the same output in response to the same set of input stimuli – could ever be regarded as truly cognitive.

We conclude that a clear and universally-agreed definition of cognitive radar does not yet exist, and one of the first priorities of any subsequent activity on this subject should be to attempt to clarify and refine these concepts and definitions.

One way of tackling this may be to consider a scale of cognition. An example of this approach may be found in a European Defence Agency (EDA) paper on Unmanned Maritime Systems (UMSs) [31] (Figure 5-3). Full details of the definition can be found in the document, but the following taken from the document describes how the notation is interpreted.

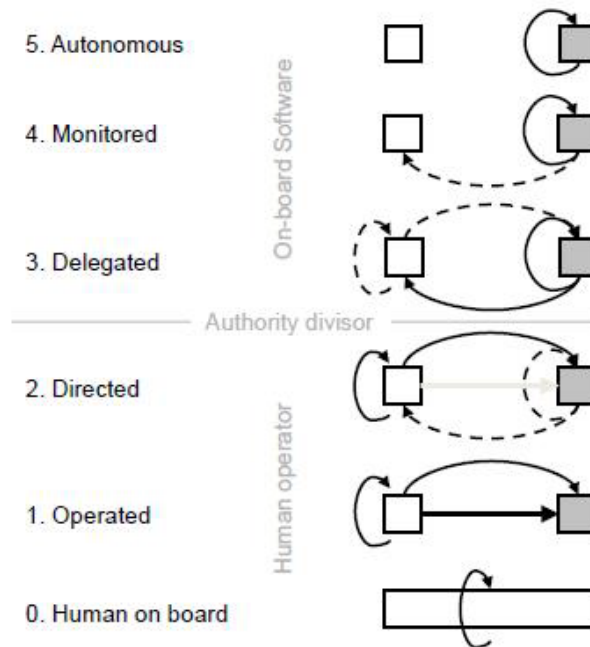

Figure 5-3: EDA Illustration of Levels of Control of Unmanned Maritime Systems.

“These control methods range from traditional manned on-board control (method 0) to Autonomous control (Method 5). White squares represent human operators. Grey squares represent on-board system/software. Filled arrows indicate data/information based on initiative and authorisation. Dotted arrows indicate data/information of less importance for the course of events. Arrows circling around a square represent reasoning and cognitive capability/function internal to the human operator or the on-board system. Arrows between squares represent data/information flowing between units. The filled horizontal arrow in Method 1 Operated UMS indicates the existence of a direct physical connection between the operator and the on-board system.”

It would be usual for a combination of the control methods described to be used during different stages of a mission, allowing different levels of human intervention depending on the complexity or nature of the task in hand.

In the USA the ALFUS (Autonomy Levels For Unmanned Systems) working group (SAE AS4D Committee) has the stated objective to define a “Framework to facilitate characterizing and articulating autonomy for unmanned systems”.

(Note UMS in the EDA scope relates to Unmanned Maritime Systems, and in ALFUS to UnManned Systems).

The ALFUS framework [75] considers overall mission complexity in terms of three orthogonal factors, namely, Mission Complexity, Environmental Complexity and Human Independence (Figure 5-4).

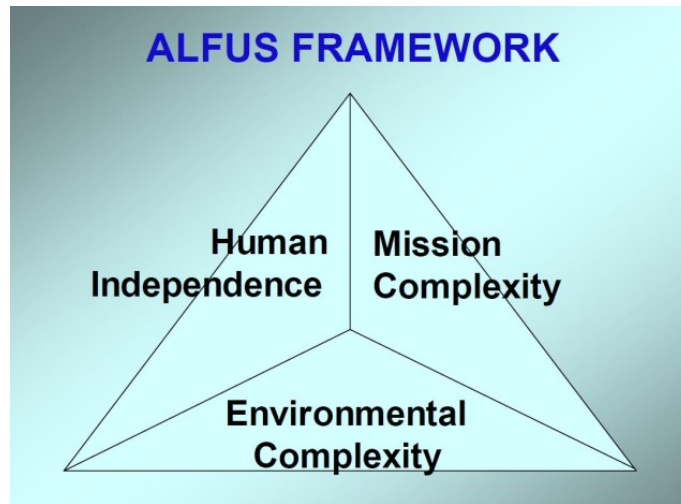

Figure 5-4: ALFUS Framework.

A 0 to 10 scale is applied to each axis and the values combined to provide an overall score, the combination not necessarily being linear. The classification of the overall result is illustrated in Figure 5-5.

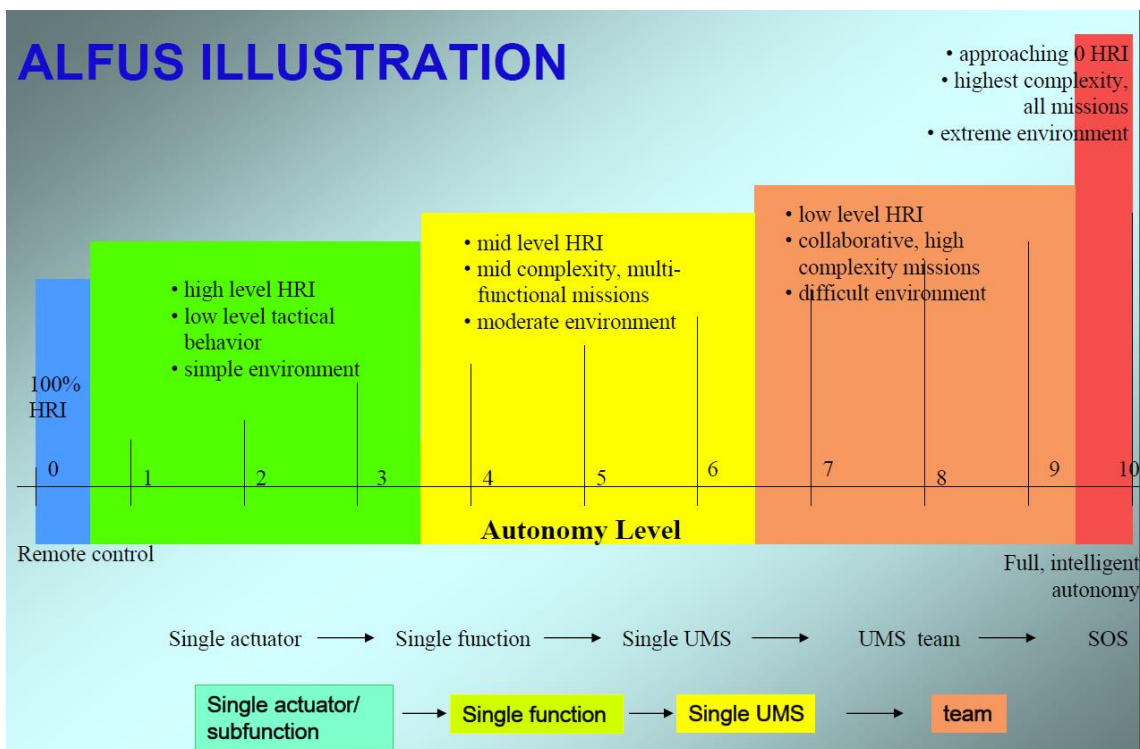

Figure 5-5: ALFUS Illustration.

Based on these considerations, we might consider a scale of cognition from 0 – 10, which might be used as a starting point for deeper consideration by a subsequent Task Group.

Table 5-1: Cognitive Radar Classification Scale for Specified System Element.

Level	Description
10	Human level cognition. Full intelligent cognitive ability, including ‘random’ environmental probing, behaviour creation, understanding, learning, reasoning, attention.
9	
8	Intelligent cognitive ability, including learning, reasoning, attention
7	
6	4 + Live learning (i.e., clutter statistics, interference)
5	3 + Live learning (i.e., clutter statistics, interference)
4	Knowledge aided selection of new operating parameters using feedback.
3	Rule-based selection of new operating parameters using feedback.
2	
1	Manual feedback control created by human subject-matter expert, i.e., mode switching.
0	No cognitive ability. No feedback control.

5.3 CONCLUSIONS AND RECOMMENDATIONS

Cognitive radar represents a potentially very significant set of techniques in spectrum engineering. If spectrum occupancy at a given point were measured as a function of frequency, direction, time, polarisation and coding, it would likely be found that the occupancy would actually be quite low. This argues that there is much to be gained from a scheme which intelligently allocates spectrum occupancy as a function of all of these variables.

However, a clear and universally-agreed definition of cognitive radar does not yet exist, and one of the first priorities of any subsequent activity on this subject should be to attempt to clarify and refine these concepts and definitions. In particular:

- There is a need to unify and refine the various definitions.
- There is a need to list and understand the **general** benefits of cognitive radar.
- There is a need to understand the **specific** benefits of cognitive radar in agreed scenarios, e.g., how much performance improvement could be gained by using a cognitive radar approach to improve the detection of difficult targets, or the operation of a radar in an anti-access/area-denial congested/contested environment. These use of cognitive approaches could result in missions being possible which were previously not possible, e.g., due to the difficult environment or the workload required on a single operator (e.g., a pilot in a fast jet). Equally, there is a need to identify applications where the benefits of cognitive radar are limited or otherwise not worthwhile.
- Virtually all of the work on cognitive radar that has been done to date has been in terms of theory or simulations. There is a pressing need to undertake some simple experiments to demonstrate the benefits practically.



Chapter 6 – REGULATORY ISSUES

6.1 SUMMARY

This section addresses regulatory issues and evolutions on the radar spectrum. Firstly, we will describe the radar spectrum environment, and some example of current interferences issues, highlighting specific problems about Guard bands and White Space.

Secondly, after a review of current regulatory standards, we will present current regulatory discussions at ITU to prepare for the next World Radio Communication Conference scheduled at the end of 2015.

6.2 TODAY’S AND FUTURE RADAR SPECTRUM ENVIRONMENTS

Surveillance, defence and security systems use a large number of specific radar sensors which are well adapted to dedicated missions, ranges, and to the laws of physics. The existing spectrum will continue to be used intensively by existing radar applications, and the pressure on available frequencies will increase.

Radar systems use two-way propagation of radio-frequency waves in free-space, reflecting a small amount of energy from targets. Then the radar-frequency is chosen to optimize many factors during radar design, such as the maximum distance to detect a target, within a limited RF power available, the reflectivity of the targets, and the propagation losses through the atmosphere.

The different kind of radar systems along the frequency spectrum could be considered at their optimal equilibrium. For a global defence system, it is impossible to use higher or lower frequency band for migrating radar sensors, without a dramatic performance degradation and an overall higher cost.

Military requirement on radars for protect against jamming drives the key capacity of frequency agility on the allocated bands.

Future key applications and new needs identified for military ground, coastal or naval systems, indicates that the number of radars in operation may continuously increase within existing bands.

The radio spectrum is a limited and scarce resource, for which the demand – most of which coming from mobile industry – is exploding. The amount of spectrum available for radar use is show in Figure 6-1 below.

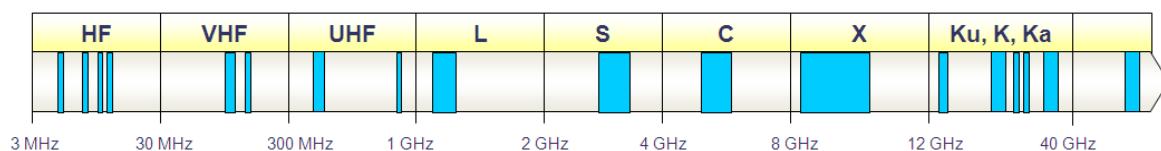

Figure 6-1: Available Spectrum for Radar Use (in blue).

Arbitrations have therefore to be done, sometimes at the expense of sectors which up until recently were protected by their governments, such as aerospace and defence.

National, regional and international spectrum policies are elaborated by governments with the view to optimize spectrum allocations among its various users (military and security forces, broadcasters, telecom operators, transport, civil aviation, scientists, etc.).

In this trend, administrations will request more progress to scientists and radio engineers to develop new technical solutions to improve spectrum occupancy, but interference issues need to be more precisely considered to master compatibility between systems and maintain or improve their operational performance and assume their mission.

6.3 CURRENT ISSUES OF INTERFERENCE BETWEEN WIRELESS AND RADAR SYSTEMS

Wireless systems are currently developed in adjacent bands of traditional L-band (~1 GHz), S-band (~3 GHz), C-band (~5 GHz) radar bands, and interferences issues could occur if commercial base station and user equipments transmit in the vicinity of radars.

In S-band, two examples of interferences issues of between wireless and S-band radar systems have been reported at ITU level, showing the complexity of the mitigation techniques which should developed.

The first study case reports about interference to NEXRAD meteorological radars in USA (two examples are shown in Figure 6-2 and Figure 6-3).



Figure 6-2: NEXRAD Weather Radar in Grand Rapids, Michigan, USA (Photo by Frank Sanders, [105, p. 7]).



Figure 6-3: Communication Systems on Tower in Broomfield, Colorado, USA (Photo by Frank Sanders, [105, p. 15]).

Frequency-separation distance separation curves have been developed for WiMAX base stations located in the vicinity of 2,700 – 3,000 MHz meteorological radars.

Measurement data indicate that OOB emissions from WiMAX base stations within the radar receiver passband are the cause of interference to NEXRADs.

Front-end overload should not occur in these receivers; OOB emissions from WiMAX base stations should be the only interference mechanism of concern for these systems.

Since the interference is due to WiMAX RF energy falling within the passband of the radar receiver, filtering applied to that radar will not mitigate the interference without also rendering the radar inoperable. Filtering applied to the radar receive path will also suppress the radar return signals.

Output RF filtering of WiMAX base station emissions can provide an effective solution to interference problems without the need to sacrifice any use of spectrum.

The second case study reports about interference to Air Traffic Control radar in the UK and possible remediation techniques to consider.

The introduction of this study stated: “The UK has identified a potential vulnerability of aeronautical and maritime radars that operate in the frequency band 2,700 – 3,100 MHz with respect to transmissions in the frequency bands 2,500 – 2,690 MHz and 3,400 – 3,600 MHz. The issue has initially been attributed to inadequate radar receiver selectivity to adjacent band transmissions although other mechanisms have not yet been ruled out. This document provides an initial quantification of radar selectivity from a UK perspective, based on information available to date.”

The conclusion of this UK study case states: “The work carried out to date clearly indicates that a range of radar receivers in the UK are potentially susceptible to planned transmissions below 2,690 MHz (such as those from mobile network base-stations) and above 3.4 GHz, even if substantially separated by frequency or geography. The effect on the operation of radars, without adjustment of the planned adjacent band transmissions and/or the performance of the radars, is predicted to be unacceptable.”

Protecting radar reception from emissions in adjacent bands (and these emissions may have a significant frequency offset from that of the radars) could impose significant constraints on the extent to which adjacent bands may be exploited by non-radar services until radars are upgraded.

Given that the types of radars operated in the UK are also used in other administrations, it seems unlikely that the general issue is unique to the UK. Therefore the UK would suggest that other administrations take account of the information in this document when planning services in bands adjacent to radar.

Information gathered so far indicates that the level of susceptibility varies according to the radar type. Generally, newer solid-state ATC radars have better adjacent band signal rejection and hence are thought to be less susceptible than some older types of Magnetron/TWT ATC radars. Studies are planned in the UK to obtain the further data that is needed to assess the extent to which radar types, other than the radar tested, are susceptible to signals generated in adjacent bands.

It is important, in the interests of safety as well as those of prospective users of the frequency bands 2,500 – 2,690 MHz and 3,400 – 3,600 MHz bands that this issue is addressed as a matter of urgency.

In the longer term, it may be necessary to take concerted international action to improve radar receiver selectivity in the interests of securing optimal use of the radio spectrum.”

These two examples are under publication, but preliminary technical information is already available in ITU WP5B Chairman Report of May 2014 (Ref. 5B/636 Annex 23 “Preliminary draft new Report ITU-R M. [OOB S-BAND] – Assessment of interference to radars operating within the 2,700 – 2,900 MHz band from broadband wireless systems operating in adjacent frequency bands”).

6.4 SHARING STUDIES FOR COEXISTENCE OF SYSTEMS IN THE SAME BAND

This case considers two or more systems sharing the same allocated frequency band, and the sharing studies have to calculate the level of interference to each system to determine if cohabitation is possible with a technical margin, and in special case with a supplementary safety-of-life margin.

As systems are sharing same frequencies, the large required attenuation between systems should be mainly provided by geometrical separation distances and cross-antennas patterns. Taking into account modulations is currently limited to consider peak power and average power values of signals. Sometimes, on a case by case basis, an estimated processing gain (which could be a positive or negative value) is used to reflect susceptibility or robustness of signal processing functions of the victim system toward interfering signals.

6.5 SHARING STUDIES FOR COEXISTENCE OF SYSTEMS IN ADJACENT BANDS

This case considers two or many systems using attributed frequencies (or assumed to be attributed) in two adjacent allocated band.

Similarly to previous paragraph, the sharing studies have to calculate the level of interference to each system to determine if cohabitation is possible with a technical margin, and in special case with a supplementary safety-of-life margin.

As systems are not sharing same operational frequencies, an extra attenuation is provided by the frequency shift between the transmitting system and the receiving system.

A necessary guard band, also called frequency offset, (space between actual transmits bands) is to be defined and enforced for maintaining good performances of all systems.

Many electronic phenomena have to be properly considered to define a necessary guard band, such as on one hand the out-of-band spectrum of the transmitter and on the other the receiving selectivity and out-of-band susceptibility. Many factors should be considered such as RF filter roll-off characteristics, LNA blocking on interfering large signals, multi-tone intermodulation products occurring in the RF LNA and in all mixers, and the IF filter roll-off.

Using an additional processing gain to reflect susceptibility or robustness of signal processing functions of the victim system toward out-of-band and intermodulation products of interfering signals is not currently obvious. Some kind of hypothesis like noise-like signals could be used but need further investigations, because new communication waveforms are very complex structured signals with time, frequency, and phase coded domains. These new modern broadband signals or their interacting products could pass through radar processing and raise the false alarm rate or trigger detection levels. An ITU report is under preparation on this subject.

During adjacent sharing studies, if the attenuation provided by the necessary frequency guard band is over-estimated (due to insufficient knowledge in electronic radar receiver design) then geometrical separation distances could be falsely underestimated, to fill the necessary global attenuation budget. For example, some fast optimistic studies lead to falsely estimate few hundreds of meters between mobile communications systems and radars, not reflecting experimental measurements.

This aspect is crucial to properly design new systems in the vicinity of radars, which would be operational without cohabitation problems neither expensive remediation.

6.6 WHITE SPACE

In the spectrum management arena, white space refers to frequencies that have been allocated to broadcast services, such as UHF television in the USA, but are not used by local broadcasters.

With the change in the USA from analog to digital television broadcasts on June 12, 2009, television frequencies which operated between 54 MHz and 806 MHz (54 MHz–72 MHz, 76 MHz–88 MHz, 174 MHz–216 MHz, 470 MHz–608 MHz, 614 MHz–806 MHz) corresponding to Channels 2 –69 ceased operation.

The USA and other Nations allocate spectrum for specific uses and provide authorization to broadcast over assigned frequencies. This frequency allocation process establishes a band plan, which designates white space between occupied channels to avoid adjacent-channel interference. While the frequencies are not used, they have been specifically assigned for use as guard bands. In addition to white space assigned for the avoidance of adjacent-channel interference, there is also unused radio spectrum which either has never been used or is becoming free as a result of technical changes, such as the conversion from analog to digital television transmission.

In recent years, there has been discussion in the radar community concerning the use of white space for radar due to the ability to detect targets at VHF and UHF which might not be detected at frequencies above 2000 MHz due to the employment of radar cross-section reduction strategies. A problem that must be confronted, however, is the size and weight of high-gain antennas required to support radars operating below 800 MHz, particularly when installed on ships and aircraft.

6.7 CURRENT RADAR REGULATORY STANDARDS

6.7.1 Regulatory Standards at Worldwide Level – ITU

At international worldwide level, ITU-R Recommendations are in force.

ITU-R defines a set of recommendations about spectrum management grouped in “Series SM”. Find hereafter list of them in which radar systems are mainly taking into account:

- REC. SM.328 Spectra and bandwidth of emissions.
- REC. SM.329 Unwanted emissions in the spurious domain.
- REC. SM.1138 Determination of necessary bandwidths including examples for their calculation and associated examples for the designation of emissions.
- REC. SM.1535 Protection of Safety Services from Unwanted Emissions.
- REC. SM.1539 Variation of the boundary between the out-of-band and spurious domains required for the application of Recommendations SM.1541 and SM.329.
- REC. SM.1540 OOB falling into adjacent allocated bands.
- REC. SM.1541 Unwanted emissions in the out-of-band domain.
- REC. SM.1542 Protection of Passive Services from Unwanted Emissions.
- REC. SM.1633 Compatibility analysis between passive and active services.
- REC. SM.1752 Limits for unwanted emissions under free-space condition.
- APPENDIX 3 Tables of maximum permitted power levels for spurious or spurious domain emissions.

6.7.2 Regulatory Standards at European Level – NATO

At European level, with respect to ITU-R, civil standards are defined by CEPT ERC Recommendations.

In this scope, radars are mainly concerned with:

- ECC RECOMMENDATION (02)05 ON UNWANTED EMISSIONS.
- ERC REC 74-01 in relation with ITU-RSM.329-10 “Unwanted emissions in the spurious domain”.

A growing trend for European military applications is to use NATO/STANAG standards in preference to national regulatory standards. In this scope, radars are mainly concerned with:

- STANAG 4370 AECTP 250 “Definitions of Electrical /Electromagnetic Environment”.
- STANAG 4370 AECTP 500 “Electrical Test”.

For example, Report CEN-WS10-EG7/N051 “Electromagnetic environment” explains and recommends:

“The European Commission requested the European Committee for Standardisation (CEN) to establish Workshop 10 to improve the efficiency and enhance competitiveness of the European defence industry. Eight Expert Groups (EG) have been established in the beginning of 2004. EG 7 is for Electromagnetic Environmental Effects (EEE, EMC in IEC terms). EG 7 has selected the EEE standards used within the member states of the European Union, approximately 430, and made a preference list. The database with standards has been published in 2004.”

In conclusions, to achieve common European EMC standards, instead of the plethora of national standards, is a significant undertaking and will take some years to finalise. EG7 has accomplished significant steps towards this but continued improvements are dependent on other forums and authorities.

Three hundred and twenty-nine (329) standards with relevance for the work of EG7 were found in the initial handbook and added references:

- A number of standards can be replaced by the recommended STANAG 4370 AECTP 500.
- Of the ‘Use’ category a significant number could be eliminated if the recommendations of this report are followed and are successful.
- Many standards are not recommended for use.
- Many standards are mostly for guidance.

EG7 conclude that:

- The scope and quality of IEC (based) standards is insufficient for military purposes except in environments similar to domestic or industrial.
- STANAGs must be used as the basis of harmonization of military standards. The low acceptance level of the STANAGs is a threat to this process. Guidance and support from WS10 is therefore needed and appreciated.

6.7.3 Spectrum Enforcement and Legal Issues

Although each Nation is sovereign about the usage of frequencies on its territory, it could be bound by their bilateral and multi-lateral engagements. In particular, ITU Radio Communication Regulation needs to be considered as a Treaty. Regulatory standards and recommendation are particularly important for cross-border coordination. Many land, maritime, air and space systems could be in touch with foreign countries borders, and spectrum enforcement and legal issues could be raised.

Many critical systems required to be protected of severe interferences from others, such as:

- Systems declared “safety-of-life” run under safety services with specific enhanced Protection Criteria, such as I/N ratio, or specific allocated bands such as Aeronautical Services.
- Radio astronomy or satellite passive sensors needs low disturbance to perform their mission.

At national level, spectrum enforcement is mainly a trade-off between Departments under the responsibility and final decision of the Prime Minister.

With commercial expensive licences sold to mobile operators since many years, States are involved to fulfil contractual requirements. For example, major technical evolution of existing systems could become legal affairs, if not forecast during licence pricing auction process.

6.7.4 Common Definitions

We recall hereafter few ITU terms necessary to understand regulatory standards:

- Radar: A radio-determination system based on the comparison of reference signals with radio signals reflected, or retransmitted, from the position to be determined.
- Primary Radar: A radio-determination system based on the comparison of reference signals with radio signals reflected from the position to be determined.
- Secondary Radar: A radio-determination system based on the comparison of reference signals with radio signals retransmitted from the position to be determined.
- Radar Beacon (Racon): A transmitter-receiver associated with a fixed navigational mark which, when triggered by a radar, automatically returns a distinctive signal which can appear on the display of the triggering radar, providing range, bearing and identification information.
- Out-of-Band Emission: Emission on a frequency or frequencies immediately outside the necessary bandwidth which results from the modulation process, but excluding spurious emissions.
- Spurious Emission: Emission on a frequency or frequencies which are outside the necessary bandwidth and the level of which may be reduced without affecting the corresponding transmission of information. Spurious emissions include harmonic emissions, parasitic emissions, intermodulation products and frequency conversion products, but exclude out-of-band emissions.
- Unwanted Emissions: Consist of spurious emissions and out-of-band emissions.
- An Out-of-Band Domain (of an emission): The frequency range, immediately outside the necessary bandwidth but excluding the spurious domain, in which out-of-band emissions generally predominate. Out-of-band emissions, defined based on their source, occur in the out-of-band domain and, to a lesser extent, in the spurious domain. Spurious emissions likewise may occur in the out-of-band domain as well as in the spurious domain.
- Spurious Domain (of an emission): The frequency range beyond the out-of-band domain in which spurious emissions generally predominate.
- Assigned Frequency Band: The frequency band within which the emission of a station is authorized; the width of the band equals the necessary bandwidth plus twice the absolute value of the frequency tolerance. Where space stations are concerned, the assigned frequency band includes twice the maximum Doppler shift that may occur in relation to any point of the Earth’s surface.

6.8 SPECTRUM REGULATORY DISCUSSIONS

6.8.1 Spectrum Regulatory Discussions at National Level

Spectrum Regulatory discussions at national level are done between Departments and other stakeholders to share current and future spectrum resources, in the view of frequency attribution, spectrum re-farming or remediation programs. National discussions contribute to establish trade-off between national interests between different radio services and radio systems, leading to prepare international positions and proposals of ITU member states.

WRC preparation and evolution of ITU Recommendations are a great part of national discussions.

6.8.2 Spectrum Regulatory Discussions at Regional Level

Spectrum Regulatory discussions could be led also at regional level to develop common positions for next WRC, and to elaborate new regulatory standards between a regional group of countries to obtain harmonized allocations or technical standards.

In Europe, regional discussions are performed in European Commission, and in the CEPT organisation.

In America, regional discussions are performed within the CITEL organisation.

6.8.3 Spectrum Regulatory Discussions at ITU-R Level

Two types of spectrum regulatory discussions are done in the ITU-R process.

The first is a continuous process for delivering technical reports or ITU recommendations.

ITU-R discussions concerning radio-determination services, which cover radar systems, are performed under responsibility of Study Group 5, Work Party 5B, except for sharing studies and positions on WRC15 Agenda Item 1.1 “New allocated bands for IMT” which are under responsibility of Joint Task Group JTG4-5-6-7.

These discussions could be about protection criteria, radar characteristics, technical report on interferences or remediation techniques, and sharing studies with radars systems.

The second is a cyclic process to prepare technical sharing studies and positions for helping next World Radio Conference to take decisions or resolutions to modify the radio communication regulations.

For example, the last two World Radio Conferences (WRCs) were held in January/February of 2012 (WRC-12) and in November of 2015 (WRC-15).

Around 2500 participants should attend, representing nearly 145 countries. They review and update the International Radio Regulations which govern frequency allocations to services relying on radio waves. Those services range from fixed point to point links, wireless LANs, mobile networks, radars, to all satellite applications (telecommunications, navigation, earth exploration, science).

Only Member States are allowed to express positions in the meeting rooms, and WRC decisions are both technical and political. They are binding.

The WRC-15 agenda, defined during former WRC-12, is made up of a number of topics that are either important for specific radar projects or for technology development or even for defining improved regulatory status for radar services.

Years before WRC, specific working parties are periodically organized to define technical reports on impacts of introducing future systems, and different possibilities to change regulations to add new radio services.

6.8.4 WRC 2015 Agenda Items Related to Radars

This section aims at describing the main WRC-15 agenda items at stake for the radar community. In ITU-R spectrum allocation, radars systems are identified under radio localisation or radio navigation services.

WRC15 will discuss 18 agenda items on new spectrum allocations, 5 are dealing with radar issues.

Most of the topics aim at reviewing the conditions of usage of different frequency bands. These conditions can be market or technology enhancers, or killers, depending on the results achieved.

Some of the agenda items are rather new frequency allocations topics to the radio location service that could lead to new radar developments, in the frequency bands 8.7 – 10.5 GHz (SAR on satellite) and 78 GHz (Automotive).

Some others are related to new threats for radar systems by allocations of other services to radio location bands, such as future recommendations for IMT (L, S, C radar bands), and new additional allocations to the fixed-satellite service (10 – 17 GHz) and WAIC airborne intra-communications (S radar band).

a) Item 1.1: IMT Bands (International Mobile Telecommunication)

“to consider additional spectrum allocations to the mobile service on a primary basis and identification of additional frequency bands for IMT and related regulatory provisions, to facilitate the development of terrestrial mobile broadband applications, in accordance with Resolution [IMT] (WRC-12)”;

ITU-R discussions trends:

L-Band: Studies demonstrate that co-channel for IMT and radars systems is not possible in 1.35 – 1.4 GHz. Some studies propose to split 1.300 – 1.350/1.375 GHz and 1.350/1.375 – 1.400 GHz respectively for radars and IMT, but the guard bands [5, 10, 20 MHz or more] need to be defined.

S-Band: Studies demonstrate that co-channel for IMT and radars systems is not possible in 2.7 – 2.9 GHz. Some studies, not in the WRC A11.1 mandate, propose to split 2.7 – 2.9 GHz for separate sub-bands respectively for IMT and radars, but the guard bands [20, 30, 60 MHz] to be carefully defined. Many countries and ICAO are against this short idea due to the costly migration or abandon of numerous radar systems. Moreover, this splitting idea will be poor spectral efficient and would not to lead to a worldwide harmonized IMT band.

C-Band: Studies try to demonstrate that RLAN cannot mitigate with fast hopping radars in 5.35 – 5.47 GHz.

b) Item 1.6: FSS 10 – 17 GHz

“to consider possible additional primary allocations:

1.6.1 to the fixed-satellite service (Earth-to-space and space-to-Earth) of 250 MHz in the range between 10 GHz and 17 GHz in Region 1;

1.6.2 to the fixed-satellite service (Earth-to-space) of 250 MHz in Region 2 and 300 MHz in Region 3 within the bands 13 – 17 GHz;

and review of the regulatory provisions on the current allocations to the fixed-satellite service within this range, taking into account the results of ITU-R studies, in accordance with Resolutions [FSS_R1] (WRC-12) and [FSS_R2_R3] (WRC-12) respectively;”

ITU-R discussions trends:

Sharing studies with 10.0 – 10.55 GHz, 10.55 – 10.68 GHz, 15.4 – 17.3 GHz radio localisation bands.

c) Item 1.12: SAR onboard satellite

“to consider an extension of the current worldwide allocation to the Earth exploration-satellite (active) service in the frequency band 9,300 – 9,900 MHz by up to 600 MHz within the frequency bands 8,700 – 9,300 MHz and/or 9,900 – 10,500 MHz, in accordance with Resolution [EESS600MHz] (WRC-12);”

ITU-R discussions trends:

Sharing studies show compatibility with ground radars in 8,700 – 9,300 MHz radio location and 9,900 – 10,500 MHz radio location bands.

d) Item: 1.17 WAIC

“to consider possible spectrum requirements and regulatory actions, including appropriate aeronautical allocations, to support Wireless Avionics Intra-Communications (WAIC), in accordance with Resolution [AI 8.2 /WAIC] (WRC-12);”

ITU-R discussions trends:

2.7 – 2.9 GHz radio location, aeronautical radio navigation is identified in the preliminary list of candidate bands for WAIC systems, but most of leading countries are converging to another not radar band higher in frequency.

e) Item: 1.18 SRR at 78 GHz

“to consider a primary allocation to the radio location service in the 77.5 – 78.0 GHz frequency band in accordance with Resolution [RLS-78 GHz] (WRC-12);”

For short-range radars for automotive applications.

Chapter 7 – CONCLUSIONS AND RECOMMENDATIONS

7.1 SUMMARY AND CONCLUSIONS

The growing requirements of NATO's military and the individual national defence organization to gather, analyze, and share information rapidly, to control an increasing number of automated Intelligence, Surveillance, and Reconnaissance (ISR) assets, to command geographically dispersed and mobile forces to gain access into denied areas, and to "train as we fight" adequately requires that these organizations maintain sufficient spectrum access. Additionally, adversaries are aggressively developing and fielding electronic-attack and cyber technologies that significantly reduce the ability to access the spectrum and conduct military operations. Concurrently, the global wireless broadband industry's demand for spectrum is driven by consumer demand for greater mobility and better data access. These competing requirements for finite spectrum resources have changed the spectrum landscape, nationally and internationally, for the foreseeable future. Going forward, NATO and national leaders will be challenged to make decisions that balance national security with economic interests. In the USA, a DoD Electromagnetic Spectrum Strategy (DESS) has been developed by the DoD Chief Information Officer (DoD CIO) as a call to action that DoD must act now to be able to operate in the congested and contested electromagnetic environments of the future. Similarly, NATO military bodies must change how they address spectrum resources, from technologies developed in acquisition to the tools for planning its use. The approach must include acquiring more efficient, flexible, and adaptable systems while developing more agile and opportunistic spectrum operations to ensure that our forces can complete their missions. Courses of action with spectrum strategies with strategic initiatives must be developed. The strategic initiatives should address advancing technologies to ease spectrum congestion, should promote sharing of spectrum to avoid band relocation, should increase the fidelity and availability of modeling and simulation of spectrum-related attributes, and should improve the visibility and oversight of department spectrum dependency decisions.

7.2 RECOMMENDATIONS

To address the spectrum problem with regard to radar operation and interoperability, a collaborative team of NATO military, industry, and academic experts in various facets of radar technology is needed to address the spectrum problems facing current (legacy) and future radar systems. In particular, such a collaborative team of experts must include the multiple disciplines of radar including electromagnetics, signal processing, and systems and component engineering. The expressed purpose of this teaming is to solve spectrum-related design and interoperability problems between radars and other spectrum users, particularly wireless communication. The team's areas of expertise should cover:

- 1) Radar spectrum engineering;
- 2) Electromagnetic theory and modeling (EMI/EMC);
- 3) Radar system analysis, design, and testing;
- 4) Signal processing;
- 5) Waveform design;
- 6) Microwave tube design, test, and evaluation;
- 7) RF/microwave filter design;
- 8) Transmitter design and integration;
- 9) RF/microwave component design;
- 10) Radar receiver design;

CONCLUSIONS AND RECOMMENDATIONS

- 11) RF/microwave power amplifier design; and
- 12) Digital transceiver design.

All of these disciplines are needed due to the multi-disciplinary approach that will be required to address this problem. Additionally, the solutions that must be developed during this effort must address both current and future systems. This approach will insure long-term interoperability between legacy and future systems, maintaining current capability with legacy systems and allowing for system upgrades, while not constraining the performance of future systems so as to allow new capabilities.

General research areas that need to be addressed in subsequent SET activities include:

- 1) The design of efficient power amplifiers (solid-state and tube) and transmitter configurations to provide improved spectral purity.
- 2) Adaptable transmit filters and antenna technology for active arrays that more completely integrate EM theory and signal processing.
- 3) Adaptive/cognitive waveform design for spatial/spectral interference avoidance on transmit.
- 4) Optimization of radar emissions accounting for non-ideal/non-linear aspects of the transmitter.
- 5) Development of radar emission structures that induce minimal interference to commercial users in adjacent spectral bands.
- 6) Innovative receiver designs supporting digital signal processing for in-band reception and adjacent-band interference rejection.

In addition, experimental assessments of prospective solutions should be evaluated at appropriate testing venues, a roadmap should be developed that will allow NATO to make facts-based decisions on the best way forward to update and improve legacy systems and to determine critical requirements for the acquisition of future systems, trade studies should be conducted to determine which of the identified solution approaches will provide the most sensor capability and system immunity while minimizing life cycle costs, and an information database of the results of the research and validation testing should be created to guide industry and academia in developing improved standards and approaches for the development of future commercial products. This impact of the suggested database should not be dismissed or minimized, as improvements in commercial systems can reduce future interference problems with NATO military systems, as well as will increase a technology base that should keep acquisition costs down. Furthermore, the SET-182 team strongly recommends the following:

- More collaboration between the communication and military governing bodies.
- Identify and allocate significant funding for R&D spectrum research. This funding should be disseminated to teams with members from academia, industry, and government research laboratories, with the government research laboratories as the leads.
- NATO governing organizations for radar and NATO military take a much more significant role in helping the wireless community develop systems and standards that are robust to radar emissions.
- Acquisition program managers for military systems must have greater involvement in radar spectrum management. If collaboration and interaction is to become a reality, their heavy involvement is a necessity.
- The wireless community and the policy makers need a better understanding of radar requirements and how the operation of wireless can adversely affect radar.

Chapter 8 – REFERENCES

- [1] 3GPP standard, LTE; Evolved Universal Terrestrial Radio Access (E- UTRA); Base Station (BS) radio transmission and reception (3GPP TS 36.104 version 10.2.0 Release 10), 2011.
- [2] D.K. Abe, K.T. Nguyen, D.E. Pershing, F.N. Wood, R.E. Myers, E.L. Eisen, M. Cusick and B. Levush, “Demonstration of a 600 kW Multiple-Beam Klystron Amplifier: A First-Pass Design Success”, NRL Review, Naval Research Laboratory, Washington, DC, USA, pp. 1-3, 2005.
- [3] A. Alhabashna, O.A. Dobre, R. Venkatesan and D.C. Popescu, “Cyclostationarity-Based Detection of LTE OFDM Signals for Cognitive Radio Systems”, *IEEE Globecom Conference 2010*, Miami, FL, USA, 6-10 December 2010.
- [4] https://www.asdreports.com/news.asp?pr_id=1701, Accessed 26 June 2014.
- [5] C.J. Baker, H.D. Griffiths and I. Papoutsis, “Passive Coherent Radar Systems - Part II: Waveform Properties”, *IEE Proc. Radar, Sonar and Navigation*, Vol. 152, No. 3, pp. 160-168, June 2005.
- [6] C. Baylis, M. Moldovan, L. Wang and J. Martin, “LiNC Power Amplifiers for Reducing Out-of-Band Spectral Re-Growth: A Comparative Study”, *IEEE Wireless and Microwave Technology Conference*, Melbourne, FL, USA, 12-13 April 2010.
- [7] C. Baylis, R.J. Marks, J. Martin, H. Miller and M. Moldovan, “Going Nonlinear”, *IEEE Microwave Mag.*, Vol. 12, No. 2, pp. 55-64, April 2011.
- [8] C. Baylis, L. Wang, M. Moldovan, J. Martin, H. Miller, L. Cohen and J. de Graaf, “Designing Transmitters for Spectral Conformity: Power Amplifier Design Issues and Strategies”, *IET Radar, Sonar & Navigation*, Vol. 5, No. 6, pp. 681-685, July 2011.
- [9] C. Baylis, M. Fellows, L. Cohen and R.J. Marks II, “Solving the Spectrum Crisis: Intelligent, Reconfigurable Microwave Transmitter Amplifiers for Cognitive Radar”, *IEEE Microwave Mag.*, July 2014.
- [10] M.R. Bell, “Information Theory and Radar Waveform Design”, *IEEE Trans. Information Theory*, Vol. 39, No. 5, pp. 1578-1597, September 1993.
- [11] A. Birafane, M. El-Asmar, A.B. Kouki, M. Helaoui and F.M. Ghannouchi, “Analyzing LiNC Systems”, *IEEE Microwave Mag.*, Vol. 11, No. 5, pp. 59-71, August 2010.
- [12] S.D. Blunt and K. Gerlach, “Adaptive Pulse Compression via MMSE Estimation”, *IEEE Trans. Aerospace & Electronic Systems*, Vol. 42, No. 2, pp. 572-584, April 2006.
- [13] S.D. Blunt and K. Gerlach, “Multistatic Adaptive Pulse Compression”, *IEEE Trans. Aerospace and Electronic Systems*, Vol. 42, No. 2, pp. 572-584, April 2006.
- [14] S.D. Blunt, W. Dower and K. Gerlach, “Hybrid Interference Suppression for Multistatic Radar”, *IET Radar, Sonar, & Navigation*, Vol. 2, No. 5, pp. 323-333, October 2008.
- [15] S.D. Blunt, A. Shackelford, K. Gerlach and K.J. Smith, “Doppler Compensation & Single Pulse Imaging via Adaptive Pulse Compression”, *IEEE Trans. Aerospace & Electronic Systems*, Vol. 45, No. 2, pp. 647-659, April 2009.

REFERENCES

- [16] S.D. Blunt, M. Cook, E. Perrins and J. de Graaf, "CPM-Based Radar Waveforms for Efficiently Bandlimiting a Transmitted Spectrum", *Proceedings of the 2009 IEEE Radar Conference*, Pasadena, CA, USA, May 4-8 2009.
- [17] S.D. Blunt and T. Higgins, "Dimensionality Reduction Techniques for Efficient Adaptive Radar Pulse Compression", *IEEE Trans. Aerospace & Electronic Systems*, Vol. 46, No. 1, pp. 349-362, January 2010.
- [18] S.D. Blunt, T. Chan and K. Gerlach, "Robust DOA Estimation: The Re-iterative Super-Resolution (RISR) Algorithm", *IEEE Trans. Aerospace & Electronic Systems*, Vol. 47, No. 1, pp. 332-346, January 2011.
- [19] S.D. Blunt, M. Cook, J. Jakabosky, J. de Graaf and E. Perrins, "Polyphase-Coded FM (PCFM) Radar Waveforms, Part I: Implementation", *IEEE Trans. Aerospace & Electronic Systems*, Vol. 50, No. 3, pp. 2219-2230, July 2014.
- [20] S.D. Blunt, J. Jakabosky, M. Cook, J. Stiles, S. Seguin and E.L. Mokole, "Polyphase-Coded FM (PCFM) Radar Waveforms, Part II: Optimization", *IEEE Trans. Aerospace & Electronic Systems*, Vol. 50, No. 3, pp. 2231-2242, July 2014.
- [21] R. Chen and B. Cantrell, "Highly Bandlimited Radar Signals", *Proceedings of the 2002 IEEE Radar Conference*, pp. 220-226, April 1-3, Long Beach, CA, USA, 2002.
- [22] Y.H. Chin, "Design and Performance of L-Band and S-Band Multi Beam Klystrons", *Proc. XXIV Linear Accelerator Conference (LINAC08)*, Victoria, BC, Canada, pp. 369-373, 29 September – 3 October 2008.
- [23] H. Chireix, "High Power Outphasing Modulation", *Proc. IRE*, Vol. 23, pp. 1370-1392, November 1935.
- [24] M. Cook, J. de Graaf, S. Blunt, E. Perrins and J. Jakabosky, "Assessment of CPM-Based Polyphase-Coded Waveforms for Saturated Power Amplifiers", *MSS Tri-Service Radar Symposium*, Monterey, CA, USA, June 2011.
- [25] B.D. Cordill, S.A. Seguin, L.S. Cohen, J. de Graaf and M. Parent, "Spectrum Attributes of Frequency-Steerable Phased Array Antennas", *2012 IEEE International Symposium on Electromagnetic Compatibility*, Pittsburgh, PA, USA, p. 571, August 2012.
- [26] D. Cox, "Linear Amplification with Nonlinear Components", *IEEE Trans. Communications*, Vol. 22, No. 12, pp. 1942-1945, December 1974.
- [27] E. Dahlman, S. Parkvall and J. Sköld, "4G-LTE/LTE-Advanced for Mobile Broadband", *Elsevier Ltd.*, 2014.
- [28] M.E. Davis, "Foliage Penetration Radar: Detection and Characterization of Objects Under Trees", *SciTech Inc.*, Raleigh, NC, USA, 2011.
- [29] J. De Graaf, H. Faust, J. Alatishe and S. Talapatra, "Generation of Spectrally Confined Transmitted Radar Waveforms: Experimental Results", *2006 IEEE Radar Conference*, Verona, NY, USA, pp. 76-83, 24-27 April 2006.
- [30] W.H. Doherty, "A New High Efficiency Power Amplifier for Modulated Waves", *Proc. IRE*, Vol. 24, No. 9, pp. 1163-1182, September 1936.

- [31] “Best Practice Guide for Unmanned Maritime Systems Handling, Operations, Design and Regulations”, *European Defence Agency*, December 2014.
- [32] M. Edrich, “Multiband Multistatic Passive Radar System for Airspace Surveillance: A Step Towards Mature PCL Implementations”, International Conference *RADAR 2013*, Adelaide, Australia, 10-12 September 2013.
- [33] A. Evers and J. Jackson, “Analysis of an LTE Waveform for Radar Applications”, *IEEE Radar Conference 2014*, Cincinnati, OH, USA, 19-23 May 2014.
- [34] H. Faust, B. Connolly, T. Firestone, R. Chen, B. Cantrell and E.L. Mokole, “A Spectrally Clean Transmitting System for Solid-State Phased-Array Radars”, *Proceedings of the 2004 IEEE Radar Conference*, pp. 140-144, April 26-29, Philadelphia, PA, USA, 2004.
- [35] H.H. Faust, E.L. Mokole and B.H. Cantrell, “Spectrally Confined Waveforms for Solid-State Transmit Modules”, *Proceedings of the IEEE/IEE Waveform Diversity & Design 2004 Conference*, November 8-10, Edinburgh, Scotland, 2004.
- [36] H. Faust, J. de Graaf and J. Alatishe, “The Effects of a Solid-State Power Amplifier on Spectrally Confined Radar Waveforms”, *Proceedings of the 2005 IEEE International Radar Conference*, May 9-12, Washington, DC, USA, 2005.
- [37] M. Fellows, C. Baylis, J. Martin, L. Cohen and R.J. Marks II, “Direct Algorithm for the Pareto Load-Pull Optimisation of Power-Added Efficiency and Adjacent-Channel Power Ratio”, *IET Radar, Sonar & Navigation*, Vol. 8, No. 9, pp. 1280-1287, December 2014.
- [38] M. Fellows, C. Baylis, L. Cohen and R.J. Marks II, “Real-Time Load Impedance Optimization for Radar Spectral Mask Compliance and Power Efficiency”, *IEEE Trans. Aerospace & Electronic Systems*, Vol. 51, No. 1, pp. 591-599, January 2015.
- [39] M. Fellows, J. Barlow, J. Barkate, M. Mosley, M. Flachsbarth, C. Baylis, L. Cohen and R.J. Marks II, “Measurement-Based Radar Waveform Optimization Using the Ambiguity function and Spectral Mask”, 2014 Texas Symposium on Wireless and Microwave Circuits and Systems, Waco, TX, USA, April 2014.
- [40] M. Fellows, M. Flachsbarth, J. Barlow, C. Baylis and R.J. Marks II, “The Smith Tube: Selection of Radar Chirp Waveform Bandwidth and Power Amplifier Load Impedance Using Multiple Bandwidth Load-Pull Measurements”, *Proceedings of the 2014 IEEE Wireless and Microwave Technology Conference (WAMICON 2014)*, Tampa, FL, USA, June 2014.
- [41] K. Gerlach, A.K. Shackelford and S.D. Blunt, “Combined Multistatic Adaptive Pulse Compression and Adaptive Beamforming for Shared-Spectrum Radar”, *IEEE Journal of Selected Topics in Signal Processing*, Vol. 1, No. 1, pp. 137-146, June 2007.
- [42] K. Gerlach, M.R. Frey, M.J. Steiner and A. Shackelford, “Spectral Nulling on Transmit via Nonlinear FM Radar Waveforms”, *IEEE Trans. Aerospace & Electronic Systems*, Vol. 47, No. 2, pp. 1507-1515, April 2011.
- [43] F. Gini, A. De Maio and L.K. Patton, “Waveform Design and Diversity for Advanced Radar Systems”, *IET*, 2012.
- [44] N.A. Goodman, P.R. Venkata and M.A. Neifeld, “Adaptive Waveform Design and Sequential Hypothesis Testing for Target Recognition with Active Sensors”, *IEEE Journal of Selected Topics in Signal Processing*, Vol. 1, No. 1, pp. 105-113, June 2007.

- [45] H.D. Griffiths and N.R.W. Long, "Television-Based Bistatic Radar", *IEE Proc.*, Vol. 133, Part F, No. 7, pp. 649-657, December 1986.
- [46] H.D. Griffiths and C.J. Baker, "Passive Coherent Radar Systems - Part I: Performance Prediction", *IEE Proc. Radar, Sonar and Navigation*, Vol. 152, No. 3, pp. 153-159, June 2005.
- [47] H.D. Griffiths, I. Darwazeh and M. Inggs, "Waveform Design for Commensal Radar", *IEEE Int. Conference RADAR 2015*, Washington, DC, USA, pp. 1456-1460, 11-14 May 2015.
- [48] H.D. Griffiths and C.J. Baker, "The Signal and Interference Environment in Passive Bistatic Radar", *Information, Decision and Control Symposium*, Adelaide, Australia, 12-14 February 2007.
- [49] J.R. Guerci, "Cognitive Radar: The Knowledge-Aided Fully Adaptive Approach", *Artech House*, 2010.
- [50] S.H. Han and J.H. Lee, "An Overview of Peak-to-Average Power Ratio Reduction Techniques for Multicarrier Transmission", *IEEE Wireless Communications*, Vol. 12, No. 2, pp. 56-65, April 2005.
- [51] S. Haykin, "Cognitive Radar: A Way of the Future", *IEEE Signal Processing Magazine*, Vol. 23, No. 1, pp. 30-40, January 2006.
- [52] S. Haykin, "Cognitive Dynamic Systems: Radar, Control, and radio", *Proc. IEEE*, Vol. 100, No. 7, pp. 2095-2013, July 2012.
- [53] S. Haykin, "Cognitive Dynamic Systems: Perception-Action Cycle, Radar and Radio", *Cambridge University Press*, 2012.
- [54] S. Haykin, Y. Xue and P. Setoodeh, "Cognitive Radar: Step Toward Bridging the Gap Between Neuroscience and Engineering", *Proc. IEEE*, Vol. 100, No. 11, pp. 3102-3130, November 2012.
- [55] H.D. Helms and J.B. Thomas, "Truncation Error of Sampling-Theorem Expansions", *Proc. IRE*, pp. 179-184, February 1962.
- [56] J. Hoversten, S. Schafer, M. Roberg, M. Norris, D. Maksimovic and Z. Popovic, "Codesign of PA, Supply, and Signal Processing for Linear Supply-Modulated RF Transmitters", *IEEE Trans. Microwave Theory & Techs.*, Vol. 60, No. 6, pp. 2010-2020, March 2012.
- [57] P.E. Howland, "Target Tracking Using Television-Based Bistatic Radar", *IEE Proc. Radar Sonar and Navigation*, Vol. 146, No. 3, pp. 166-174, June 1999.
- [58] Y. Hu, J.C. Mollier and J. Obregon, "A New Method of Third-Order Intermodulation Reduction in Nonlinear Microwave Systems", *IEEE Trans. Microwave Theory and Techniques*, Vol. MTT-34, No. 2, pp. 245-250, February 1986.
- [59] I. Hunter, E. Musonda, R. Parry, M. Guess, P. Sleish, M. Gosling and M. Meng, "Transversal Directional Filters for Channel Combining", *IET Radar, Sonar & Navigation*, Vol. 8, Iss. 9, pp. 1288-1294, 2014.
- [60] D.R. Jachowski, C. Rauscher, S.W. Kirchoefer, W. Kruppa, A.C. Guyette and J.M. Pond, "Tunable Filter and Multiplexer for Improved Transmitter Electromagnetic Compatibility", *NRL Review*, pp. 177-180, 2009.
- [61] D.R. Jachowski and C. Rauscher, "Frequency-Agile Bandstop Filter with Tunable Attenuation", *IEEE International Microwave Symp.*, Boston, MA, USA, pp. 649-652, June 2009.

- [62] M.C. Jackson, "The Geometry of Bistatic Radar Systems", *IEE Proc.*, Vol.133, Part F., No.7, pp. 604-612, December 1986.
- [63] J. Jakabosky, P. Anglin, M. Cook, S.D. Blunt and J. Stiles, "Non-Linear FM Waveform Design Using Marginal Fisher's Information within the CPM Framework", *IEEE Radar Conf.*, Kansas City, MO, USA, 23-27 May 2011.
- [64] J. Jakabosky, S.D. Blunt, M.R. Cook, J. Stiles and S.A. Seguin, "Transmitter-in-the-Loop Optimization of Physical Radar Emissions", *IEEE Radar Conference*, Atlanta, GA, USA, 7-11 May 2012.
- [65] N. Kingsley and J.R. Guerci, "Adaptive Amplifier Module Technique to Support Cognitive RF Architectures", 2014 *IEEE Radar Conference*, Cincinnati, OH, USA, May 2014, pp. 1329-1332.
- [66] N. Levanon, E. Mozeson, "Radar Signals", *Wiley – IEEE Press*, 2004.
- [67] M.J. Lindenfeld, "Sparse Frequency Transmit-and-Receive Waveform Design", *IEEE Trans. Aerospace & Electronic Systems*, Vol. 40, No. 3, pp. 851-861, July 2004.
- [68] G. Locke and L.E. Strickling, "Plan and Timetable to Make Available 500 MHz of Spectrum for Wireless Broadband", *US Dept. of Commerce Rep.*, October 2010.
- [69] J. Martin, C. Baylis, L. Cohen, J. de Graaf and R.J. Marks II, "A Peak-Search Algorithm for Load-Pull Optimization of Power-Added Efficiency and Adjacent-Channel Power Ratio", *IEEE Transactions on Microwave Theory and Techniques*, Vol. 62, No. 8, August 2014, pp. 1772-1783.
- [70] G.H. Millard, "The Introduction of Mixed-Polarization for VHF Sound Broadcasting: The Wrotham Installation", Research Department Engineering Division, *British Broadcasting Corporation*, BBC RD 1982/17, September 1982.
- [71] E.L. Mokole, M. Parent, J. Valenzi, E. Tomas, B. Gold, S.N. Samaddar and T.T. Street, "Initial Bistatic Measurements of Electromagnetic Propagation in an Enclosed Ship Environment", *Antenna Applications Symposium*, Monticello, IL, USA, pp. 1-29, September 1999.
- [72] E.L. Mokole, M. Parent, T.T. Street and E. Tomas, "RF Propagation on ex-USS Shadwell", *IEEE-APS Conference on Antennas and Propagation for Wireless Communications*, Waltham, MA, USA, pp. 153-156, November 2000.
- [73] A.K. Nehra¹, R.K. Gupta, S.M. Sharma, P.C. Panda, Y. Choyal and R.K. Sharma, "Design and Simulation of Electron Gun for a Multibeam Klystron", *Proc. International Symp. Vacuum Science & Tech. and Appl. for Accelerators*, Institute of Physics Publishing, pp. 1-4, 2012.
- [74] K.T. Nguyen, D.K. Abe, D.E. Pershing, B. Levush, E.L. Wright, H. Bohlen, A. Staprans, L. Zitelli, D. Smithe, J.A. Pasour, A.N. Vlasov, T.M. Antonsen, Jr., K. Eppley and J.J. Petillo, "High Power Four-Cavity S-Band Multiple-Beam Klystron Design", *IEEE Trans. Plasma Sci.*, Vol. 32, No. 3, pp. 1119-1135, June 2004.
- [75] "Autonomy Levels for Unmanned Systems", *National Institute for Standards and Technology (NIST)*, 16 June 2010, http://www.nist.gov/el/isd/ks/autonomy_levels.cfm.
- [76] National Telecommunications and Information Administration, U.S. Department of Commerce, "Manual of Regulations and Procedures for Federal Radio Frequency Management", May 2014 Revision of the May 2013 Edition, Chapter 5.5.

- [77] <http://media.ofcom.org.uk/news/2013/winners-of-the-4g-mobile-auction/>, Accessed 4 December 2014.
- [78] D.W. O'Hagan, H. Kuschel, M. Ummenhofer, J. Heckenbach and J. Schell, "A Multi-Frequency Hybrid Passive Radar Concept for Medium Range Air Surveillance", *IEEE AES Magazine*, Vol. 27, No. 10, pp. 6-15, October 2012.
- [79] J.E. Palmer, H.A. Harms, S.J. Searle and L.M. Davis, "DVB-T Passive Radar Signal Processing", *IEEE Trans. Signal Processing*, Vol. 61, No. 8, pp. 2116-2126, April 2013.
- [80] S.U. Pillai, H.S. Oh, D.C. Youla and J.R. Guerci, "Optimum Transmit-Receive Design in the Presence of Signal-Dependent Interference and Channel Noise", *IEEE Trans. Information Theory*, Vol. 46, No. 2, pp. 577-584, March 2000.
- [81] S. Pillai, K.Y. Li, I. Selesnick and B. Himed, "Waveform Diversity: Theory & Applications", *McGraw-Hill*, 2011.
- [82] The President's Council of Advisor on Science and Technology, "Realizing the Full Potential of Government-Held Spectrum to Spur Economic Growth", July 2012.
- [83] F.H. Raab, "Efficiency of Outphasing RF Power-Amplifier Systems", *IEEE Trans. on Communications*, Vol. Com-33, No. 10, October 1985.
- [84] F.H. Raab, P. Asbeck, S. Cripps, P.B. Kenington, Z.B. Popovic, N. Pothecary, J.F. Sevic and N.O. Sokal, "Power Amplifiers and Transmitters for RF and Microwave", *IEEE Trans. Microwave Theory & Techniques*, Vol. 50, No. 3, pp. 814-826, March 2002.
- [85] M. Richards, J. Scheer and A. Holm, "Principles of Modern Radar, Basic Principles", *SciTech Publishing*, 2010.
- [86] L. Ryan, J. Jakabosky, S.D. Blunt, C. Allen and L. Cohen, "Optimizing Polyphase-Coded FM Waveforms Within a LiNC Transmit Architecture", *IEEE Radar Conference*, Cincinnati, OH, USA, 19-23 May 2014.
- [87] A.A. Salah, R.S.A.R. Abdullah, A. Ismail, F. Hashim, C.Y. Leow, M.B. Roslee and N.E.A. Rashid, "Feasibility Study of LTE Signal as a New Illuminators of Opportunity for Passive Radar Applications", *IEEE International RF and Microwave Conference 2013*, pp. 258-262, Penang, Malaysia, 9-11 December 2013.
- [88] A.A. Salah, R.S.A. Raja Abdullah, A. Ismail, F. Hashim and N.H. Abdul Aziz, "Experimental Study of LTE Signals as Illuminators of Opportunity for Passive Bistatic Radar Applications", *Electronics Letters*, Vol. 50, No. 7 pp. 545-547, 27 March 2014.
- [89] S.N. Samaddar and E.L. Mokole, "Some Basic Properties of Antennas Associated with Ultrawideband Radiation", in *Ultra-Wideband, Short-Pulse Electromagnetics 3*, ed. C.E. Baum, L. Carin and A.P. Stone, Plenum Press, NY, USA, pp. 147-164, 1997.
- [90] T.K. Sarkar, M.C. Wicks, M. Salazar-Palma and R.J. Bonneau, "Smart Antennas", *Wiley-IEEE Press*, 2003.
- [91] T.K. Sarkar, M. Salazar-Palma and E.L. Mokole, "Physics of Multiantenna Systems and Broadband Processing", *John Wiley and Sons*, 2008.
- [92] A. Shackelford, T. Higgins, J. Alatishe, K. Gerlach and S. Blunt, "Shared-Spectrum Radar: Experimental Results", *Record of MSS Tri-Service Radar Symposium*, Orlando, FL, USA, June 2010.

- [93] M. Skolnik, "Introduction to Radar Systems", 3rd Edition, New York, NY, USA, *McGraw-Hill*, 2001.
- [94] P.D Sutton, K.E. Nolan and L.E. Doyle, "Cyclostationary Signatures for Rendezvous in OFDM-Based Dynamic Spectrum Access Networks", *IEEE DySPAN 2007*, Dublin, Republic of Ireland, 17-20 April 2007.
- [95] G.C. Tavik, C.L. Hilterbrick, J.B. Evins, J.J. Alter, J.G. Crnkovich, J.W. de Graaf, W. Habicht, G.P. Hrin, S.A. Lessin, D.C. Wu and S.M. Hagewood, "The Advanced Multifunction RF Concept", *IEEE Trans. Microwave Theory & Techns.*, Vol. 53, No. 3, pp. 1009-1020, March 2005.
- [96] T. Tsao, M. Slamani, P. Varshney, D. Weiner, H. Schwarzlander and S. Borek, "Ambiguity Function for Bistatic Radar", *IEEE Trans. Aerospace and Electronic Systems*, Vol. AES-33, pp. 1041-1051, 1997.
- [97] <http://www.bsos.umd.edu/psyc/batlab>.
- [98] J. Ward, "Space-Time Adaptive Processing for Airborne Radar", *MIT Lincoln Lab Technical Report*, #1015, December 1994.
- [99] M. Wicks, E.L. Mokole, S. Blunt, R. Schneible and V. Amuso, "Principles of Waveform Diversity & Design", *SciTech Publishing*, 2010.
- [100] N.J. Willis and H.D. Griffiths (eds), "Advances in Bistatic Radar", *SciTech Publishing Inc.*, Raleigh, NC, USA, ISBN 1 891 12148 0, 2007.
- [101] P.M. Woodward, "Probability and Information Theory, with Applications to Radar", *Pergamon Press*, 1953, Reprinted by Artech House 1980.
- [102] Y. Yang and B. Kim, "A New Linear Amplifier Using Low-Frequency Second-Order Intermodulation Component Feedforwarding", *IEEE Microwave and Guided Wave Letters*, Vol. 9, No. 10, pp. 419-420, October 1999.
- [103] G. Yuan, X. Zhang, W. Wang and Y. Yang, "Carrier Aggregation for LTE-Advanced Mobile Communication Systems", *IEEE Communications Mag.*, Vol. 48, No. 2, pp. 88-93, February 2010.
- [104] Y. Zhang and T.K. Sarkar, "Parallel Solution of Integral Equation Based EM Problems in the Frequency Domain", *Wiley-IEEE Press*, 2009.
- [105] F.H. Sanders, R.L. Sole, J.E. Carroll, G.S. Seacrest and T.L. Allmon, "Analysis and Resolution of RF Interference to Radars Operating in the Band 2700-2900 MHz from Broadband Communication Transmitters", NTIA Report 13-490, U.S. Department of Commerce, National Telecommunications and Information Administration, October 2012. <https://www.its.bldrdoc.gov/publications/download/13-490.pdf>.

REFERENCES



Annex A – LIST OF MEETINGS

First Meeting:	14-15 June 2011	RTA Headquarters, Neuilly-sur-Seine, FRA
Second Meeting:	28-29 November 2011	NRL, Washington, DC, USA
Third Meeting:	13-14 June 2012	University College London, GBR
Fourth Meeting:	17-18 October 2012	NRL, Washington, DC, USA
Fifth Meeting:	8-9 May 2013	DRDC, Ottawa, ON, CAN
Sixth Meeting:	26-27 September 2013	CSO Headquarters, Neuilly-sur-Seine, FRA
Seventh Meeting:	27-28 May 2014	NRL, Washington, DC, USA



Annex B – BIBLIOGRAPHY OF WORK/OUTPUTS OF SET-182

The work of the Task Group and its participants, and of the SET-179 Task Group, has resulted in a substantial number of publications, including Special Sessions and Tutorials at international conferences and a Special Issue in an international journal. The following provides a listing of these outputs at the time of writing of this report.

B.1 BOOK CHAPTERS

- 1) H. Griffiths and C. Baker, “Passive Bistatic Radar Waveforms” in *Waveform Design and Diversity for Advanced Radar Systems*, eds. F. Gini, A. de Maio and L. Patton, IET, 2012.
- 2) C.J. Baker, H.D. Griffiths and A. Balleri, “Biologically Inspired Waveform Diversity” in *Waveform Design and Diversity for Advanced Radar Systems*, eds. F. Gini, A. de Maio and L. Patton, IET, 2012.
- 3) S.D. Blunt, T. Higgins, A. Shackelford and K. Gerlach, “Multistatic & Waveform-Diverse Radar Pulse Compression” in *Waveform Design and Diversity for Advanced Radar Systems*, eds. F. Gini, A. de Maio and L. Patton, IET, 2012.
- 4) J.-P. Guyvarch, L. Savy and F. Le Chevalier, “Space-Time Diversity for Active Antenna Systems” in *Waveform Design and Diversity for Advanced Radar Systems*, eds. F. Gini, A. de Maio and L. Patton, IET, 2012.

B.2 JOURNALS

- 1) C. Baylis, R.J. Marks, J. Martin, H. Miller and M. Moldovan, “Going Nonlinear”, *IEEE Microwave Mag.*, Vol. 12, No. 2, pp. 55-64, April 2011.
- 2) C. Baylis, L. Wang, M. Moldovan, J. Martin, H. Miller, L. Cohen and J. de Graaf, “Designing Transmitters for Spectral Conformity: Power Amplifier Design Issues and Strategies”, *IET Radar, Sonar & Navigation*, Vol. 5, No. 6, pp. 681-685, July 2011.
- 3) S.D. Blunt, J.G. Metcalf, C.R. Biggs and E. Perrins, “Performance Characteristics and Metrics for Intra-Pulse Radar-Embedded Communication”, *IEEE Journal on Selected Areas in Communications*, Vol. 29, No. 10, pp. 2057-2066, December 2011.
- 4) A. Balleri, H.D. Griffiths, C.J. Baker, K. Woodbridge and M.W. Holderied, “Analysis of Acoustic Echoes from a Bat-Pollinated Plant Species: Insight into Strategies for Radar and Sonar Target Classification”, *IET Radar, Sonar & Navigation*, Vol. 6, No. 6, pp. 536-544, June 2012.
- 5) J. Brown, K. Woodbridge, H. Griffiths, A. Stove and S. Watts, “Passive Bistatic Radar Experiments from an Airborne Platform”, *IEEE Aerospace and Electronic Systems Magazine*, Vol. 27, No. 11, pp. 50-55, November 2012.
- 6) P.F. Sammartino, C.J. Baker and H.D. Griffiths, “Frequency Diverse MIMO Techniques for Radar”, *IEEE Trans. Aerospace & Electronic Systems*, Vol. 49, No. 1, pp. 201-222, January 2013.
- 7) T.G. Leighton, G.H. Chua, P.R. White, K.F. Tong and H.D. Griffiths, “Radar Clutter Suppression and Target Discrimination Using Twin Inverted Pulses”, *Proc. Roy. Soc. A*, Vol. 469, No. 2160, October 2013.

- 8) T. Higgins, T. Webster and A.K. Shackelford, “Mitigating Interference via Spatial and Spectral Nulling”, *IET Radar, Sonar & Navigation*, Vol. 8, No. 2, pp. 84-93, February 2014.
- 9) S.D. Blunt, M. Cook, J. Jakobosky, J. de Graaf and E. Perrins, “Polyphase-Coded FM (PCFM) Radar Waveforms, Part I: Implementation”, *IEEE Trans. Aerospace & Electronic Systems*, Vol. 50, No. 3, pp. 2218-2229, July 2014.
- 10) S.D. Blunt, J. Jakobosky, M. Cook, J. Stiles, S. Seguin and E.L. Mokole, “Polyphase-Coded FM (PCFM) Radar Waveforms, Part II: Optimization”, *IEEE Trans. Aerospace & Electronic Systems*, Vol. 50, No. 3, pp. 2230-2241, July 2014.
- 11) C. Baylis, M. Fellows, L. Cohen and R.J. Marks II, “Solving the Spectrum Crisis: Intelligent, Reconfigurable Microwave Transmitter Amplifiers for Cognitive Radar”, *IEEE Microwave Magazine*, July 2014.
- 12) S.D. Blunt, P. McCormick, T. Higgins and M. Rangaswamy, “Physical Emission of Spatially-Modulated Radar”, *IET Radar, Sonar & Navigation*, Vol. 8, No. 9, pp. 1234-1246, December 2014 (Special issue on Spectrum Engineering, Waveform Diversity).
- 13) C. Sahin, J.G. Metcalf, S.D. Blunt and M. Rangaswamy, “Analysis of Symbol Design Strategies for Intrapulse Radar-Embedded Communications”, *IEEE Trans. Aerospace & Electronic Systems*, Vol. 51, No. 4, pp. 2914-2931, 2015.
- 14) T. Higgins, P. McCormick, S.D. Blunt and M. Rangaswamy, “Adaptive Receive Processing of Spatially-Modulated Physical Radar Emissions”, *IEEE Journal of Special Topics in Signal Processing*, Vol. 9, No. 8, pp. 1415-1426, 2015.
- 15) S.D. Blunt, J. Metcalf, J. Jakobosky, J. Stiles and B. Himed, “Multi-Waveform Space-Time Adaptive Processing”, To appear in *IEEE Trans. Aerospace & Electronic Systems*, 2017.

B.3 CONFERENCES/WORKSHOPS

- 1) B. Cordill, J. Metcalf, S.A. Seguin, D. Chatterjee and S.D. Blunt, “The Impact of Mutual Coupling on MIMO Radar Emissions”, *IEEE International Conference on Electromagnetics in Advanced Applications*, Turino, Italy, 12-17 September 2011.
- 2) J. Li, G. Liao and H. Griffiths, “Range-Dependent Clutter Cancellation Method in Bistatic MIMO-STAP Radars”, *CIE International Conference on Radar*, 24-27 October 2011.
- 3) J. Metcalf, S. Blunt and E. Perrins, “Detector Design and Intercept Metrics for Intra-Pulse Radar-Embedded Communications”, *IEEE Military Communications Conference*, Baltimore, MD, USA, 7-10 November 2011.
- 4) J. Martin, M. Moldovan, C. Baylis, R.J. Marks, L. Cohen and J. de Graaf, “Radar Chirp Waveform Selection and Circuit Optimization Using ACPR Load-Pull Measurements”, *IEEE Wireless and Microwave Technology Conference*, Cocoa Beach, FL, USA, 15-17 April 2012.
- 5) J. Jakobosky, S.D. Blunt, M.R. Cook, J. Stiles and S.A. Seguin, “Transmitter-in-the-Loop Optimization of Physical Radar Emissions”, *IEEE Radar Conference*, Atlanta, GA, USA, 7-11 May 2012.
- 6) S. Bidon, J.-Y. Tourneret and L. Savy, “Sparse Representation of Migrating Targets in Low PRF Wideband Radar”, *IEEE Radar Conference*, Atlanta, GA, USA, 7-11 May 2012.

- 7) I. Walterscheid, A.R. Brenner and J. Klare, “Radar Imaging with Very Low Grazing Angles in a Bistatic Forward-Looking Configuration”, *IEEE International Geoscience and Remote Sensing Symposium*, Munich, Germany, 22-27 July 2012.
- 8) D.J. Sego and H.D. Griffiths, “Three Dimensional RF Tomography Using Sparse Waveforms”, *IET International Conference on Radar Systems*, Glasgow, UK, 22-25 October 2012.
- 9) T. Higgins, T. Webster and A.K. Shackelford, “Mitigating Interference via Spatial and Spectral Nulls”, *IET International Conference on Radar Systems*, Glasgow, UK, 22-25 October 2012.
- 10) M. Fellows, C. Baylis, L. Cohen and R.J. Marks, “Radar Waveform Optimization to Minimize Spectral Spreading and Achieve Target Detection”, *Texas Symposium on Wireless and Microwave Circuits and Systems*, Waco, TX, USA, 4-5 April 2013.
- 11) C. Baylis, J. Martin, M. Fellows, D. Moon, M. Moldovan, L. Cohen and R.J. Marks, “Radar Power Amplifier Circuit and Waveform Optimization for Spectrally Confined, Reconfigurable Radar Systems”, *IEEE Radar Conference*, Ottawa, ON, Canada, 29 April – 3 May 2013.
- 12) T. Webster, M. Cheney and E.L. Mokole, “Modeling of Transmission, Scattering, and Reception for Multistatic Polarimetric Radar”, *IEEE Radar Conference*, Ottawa, ON, Canada, 29 April – 3 May 2013.
- 13) H. Griffiths, S. Blunt, L. Cohen and L. Savy, “Challenge Problems in Spectrum Engineering and Waveform Diversity”, *IEEE Radar Conference*, Ottawa, Canada, 29 April – 3 May 2013. (Special session on Radar Spectrum and Waveform Diversity for NATO SET-179 and SET-182).
- 14) T. Higgins, T. Webster and A.K. Shackelford, “Mitigating Interference via Spatial and Spectral Nulling: Open Air Experimental Results”, *IEEE Radar Conference*, Ottawa, ON, Canada, 29 April – 3 May 2013.
- 15) T. Webster, M. Cheney and E.L. Mokole, “Modeling of Transmission, Scattering, and Reception for Multistatic Polarimetric Radar”, *IEEE Radar Conference*, Ottawa, ON, Canada, 29 April – 3 May 2013.
- 16) J. Jakabosky, L. Ryan and S.D. Blunt, “Transmitter-in-the-Loop Optimization of Distorted OFDM Radar Emissions”, *IEEE Radar Conference*, Ottawa, ON, Canada, 29 April – 3 May 2013.
- 17) H. Griffiths and C.J. Baker, “Towards the Intelligent Adaptive Radar Network”, *IEEE Radar Conference*, Ottawa, ON, Canada, 29 April – 3 May 2013.
- 18) R.F. Tigrek and U.C. Doyuran, “Utilization of Laurent Decomposition for CPM Radar Waveform Design”, *IEEE Radar Conference*, Ottawa, ON Canada, 29 April – 3 May 2013.
- 19) J.P. Browning, H.D. Griffiths, J. Entner and P. Chen, “Depth-Based Method for Target Detection in Noisy Environments”, *IEEE Radar Conference*, Ottawa, ON, Canada, 29 April – 3 May 2013.
- 20) J.-F. Degurse, L. Savy, J.-P. Molinie and S. Marcos, “A Riemannian Approach for Training Data Selection in Space-Time Adaptive Processing Applications”, *International Radar Symposium*, Dresden, Germany, 19-21 June 2013.
- 21) J. Klare, O. Saalman and O. Biallawons, “First Imaging and Change Detection Results of the MIMO Radar MIRA-CLE Ka”, *International Radar Symposium*, Dresden, Germany, 19-21 June 2013.
- 22) M. Cattenoz, P. Brouard, A. Brun, L. Constancias and L. Savy, “Coherent Collocated MIMO Radar: A Study on Real Data”, *International Radar Symposium*, Dresden, Germany, 19-21 June 2013.

- 23) S.A. Seguin, J. Jakobosky and S.D. Blunt, “Hardware-in-the-Loop Radar Waveform Optimization Using Radiated Emissions,” *IEEE Electromagnetic Compatibility Conference*, Denver, CO, USA, 5-9 August 2013. (INVITED).
- 24) H.D. Griffiths, “Where Has All the Spectrum Gone?”, Keynote Presentation, *Proc. International Conference RADAR 2013*, Adelaide, Australia, 10-12 September 2013.
- 25) O. Rabaste, L. Savy, M. Cattenoz and J.-P. Guyvarch, “Signal Waveforms and Range/Angle Coupling in Coherent Colocated MIMO Radar”, *IEEE Intl. Radar Conference*, Adelaide, Australia, pp. 157-162, 9-12 September 2013.
- 26) S.A. Seguin, J. Jakobosky, B.D. Cordill and S. Blunt, “Phased Array Antenna Model-in-the-Loop Radar Waveform Optimization”, *IEEE Intl. Conf. on Microwaves, Communications, Antennas and Electronic Systems*, Tel Aviv, Israel, 21-23 October 2013.
- 27) B.D. Cordill, S.A. Seguin and S.D. Blunt, “Mutual Coupling Calibration Using the Reiterative Superresolution (RISR) Algorithm”, *IEEE Radar Conference*, Cincinnati, OH, USA, 19-23 May 2014.
- 28) J. Jakobosky, S.D. Blunt and B. Himed, “Optimization of “Over-Coded” Radar Waveforms”, *IEEE Radar Conference*, Cincinnati, OH, USA, 19-23 May 2014.
- 29) S.D. Blunt, P. McCormick, T. Higgins and M. Rangaswamy, “Spatially-Modulated Radar Waveforms Inspired by Fixational Eye Movement”, *IEEE Radar Conference*, Cincinnati, OH, USA, 19-23 May 2014.
- 30) L. Ryan, J. Jakobosky, S.D. Blunt, C. Allen and L. Cohen, “Optimizing Polyphase-Coded FM Waveforms Within a LINC Transmit Architecture”, *IEEE Radar Conference*, Cincinnati, OH, USA, 19-23 May 2014.
- 31) T. Webster, T. Higgins and A.K. Shackelford, “Multistatic Velocity Backprojection for Visualizing Simulated and Experimental Multistatic Radar Data”, *IEEE Radar Conference*, Cincinnati, OH, 19-23 May 2014.
- 32) D. Erricolo, H.D. Griffiths, L. Teng, M.C. Wicks and L. Lo Monte, “On the Spectrum Sharing Between Radar and Communication Systems”, *International Conference on Electromagnetics in Advanced Applications (ICEAA) 2014*, Aruba, 3-9 August 2014.
- 33) U.C. Doyuran and R.F. Tigrek, “M-ary CPM Pulse Compression Filter Design for Low, Flat Sidelobes”, *IEEE International Radar Conference*, Lille, France, 13-17 October 2014.
- 34) A.A. Gorji, R.S. Adve and R.J. Riddolls, “Waveform Optimization for Random-Phase Radar Signals with PAPR Constraints”, *IEEE International Radar Conference*, Lille, France, 13-17 October 2014.
- 35) S.D. Blunt, J. Metcalf, J. Jakobosky and B. Himed, “SINR Analysis of Multi-Waveform STAP”, *IEEE International Radar Conference*, Lille, France, 13-17 October 2014.
- 36) G. Desodt, G.-E. Michel, J.-P. Guyvarch, F. Le Chevalier and O. Rabaste, “Multi-Burst Space-Time Coding for Active Antenna Systems”, *IEEE International Radar Conference*, Lille, France, 13-17 October 2014.
- 37) H.D. Griffiths, “The Challenge of Spectrum Engineering”, Invited plenary keynote presentation, *EuRAD Conference 2014*, Rome, October 2014.

- 38) J. Jakabosky, S.D. Blunt and T. Higgins, “Ultra-Low Sidelobe Waveform Design via Spectral Shaping and LINC Transmit Architecture”, *IEEE Intl. Radar Conference*, Washington, DC, USA, 11-15 May 2015.
- 39) J. Jakabosky, S.D. Blunt and B. Himed, “Waveform Design and Receive Processing for Nonrecurrent Nonlinear FMCW Radar”, *IEEE Intl. Radar Conference*, Washington, DC, USA, 11-15 May 2015.
- 40) P. McCormick, J. Jakabosky, S.D. Blunt, C. Allen and B. Himed, “Joint Polarization/Waveform Design and Adaptive Receive Processing”, *IEEE Intl. Radar Conference*, Washington, DC, USA, 11-15 May 2015.
- 41) D. Henke, P. McCormick, S.D. Blunt and T. Higgins, “Practical Aspects of Optimal Mismatch Filtering and Adaptive Pulse Compression for FM Waveforms”, *IEEE Intl. Radar Conference*, Washington, DC, USA, 11-15 May 2015.
- 42) P.S. Tan, J. Jakabosky, J.M. Stiles and S.D. Blunt, “On Higher-Order Representations of Polyphase-Coded FM Radar Waveforms”, *IEEE Intl. Radar Conference*, Washington, DC, USA, 11-15 May 2015.
- 43) H.D. Griffiths, I. Darwazeh and M. Inggs, “Waveform Design for Commensal Radar”, *IEEE Int. Conference RADAR 2015*, Washington, DC, USA, pp. 1456-1460, 11-14 May 2015.
- 44) P. McCormick and S.D. Blunt, “Fast-Time 2-D Spatial Modulation of Radar Emissions”, *Intl. Radar Symposium*, Dresden, Germany, 24-26 June 2015.

B.4 JOURNAL SPECIAL ISSUE

- 1) IET Radar, Sonar & Navigation special section on “Waveform Diversity and Spectrum Engineering”, December 2014, Guest Editors: H. Griffiths, L. Cohen and R.F. Tigrek.

B.5 CONFERENCE ACTIVITIES

- 1) NATO SET-204 RSM on “Waveform Diversity,” Berlin, Germany, 29-30 September 2014.
- 2) *IEEE Radar Conference*, Ottawa, ON, Canada, 29 April – 3 May, 2013, Special session on “Spectrum Engineering and Waveform Diversity”, Chairs: H. Griffiths and S.D. Blunt.
- 3) *International Radar Conference*, Lille, France, 13-17 October 2014, Special session on “Waveform Diversity”, Chairs: S.D. Blunt and J. Klare.
- 4) *International Radar Symposium*, Dresden, Germany, 24-26 June 2015, Special session on “MIMO Radar”, Chairs: J. Klare and S.D. Blunt.

B.6 TUTORIALS

- 1) *International Radar Symposium India*, “Waveform Diversity and MIMO Radar” Bangalore, India, 1-5 December 2011, by R. Adve.
- 2) *Electronics Research and Development Establishment India*, “Waveform Diversity and MIMO Radar”, Pune, India, June 2012, by R. Adve.

- 3) *International Radar Symposium India*, “Advanced Signal Processing Techniques for Radar Systems”, Bangalore, India, 3-7 December 2013, by R. Adve.
- 4) *IEEE Radar Conference*, “Spectrum Engineering and Waveform Diversity”, Cincinnati, OH, USA, 19-23 May 2014, by H. Griffiths and S.D. Blunt.
- 5) *International Radar Conference*, “Spectrum Engineering and Waveform Diversity”, Lille, France, 13-17 October 2014, by H. Griffiths and S.D. Blunt.
- 6) *IEEE International Radar Conference*, “Bistatic and Multistatic Radar Systems”, Washington, DC, USA, 11-15 May 2015, by H. Griffiths.
- 7) *IEEE International Radar Conference*, “Spectrum Engineering Challenge and Waveform Diversity”, Washington, DC, USA, 11-15 May 2015, by H. Griffiths and S.D. Blunt.
- 8) *IEEE Radar Conference*, “Spectrum Engineering Challenge and Waveform Diversity”, Johannesburg, South Africa, October 2015, by H. Griffiths and S.D. Blunt.

B.7 TECHNICAL COMMITTEE

- 1) IEEE Radar Systems Panel – Waveform Diversity committee (formed in 2013), SET-182 members include S.D. Blunt, H. Griffiths and E.L. Mokole.

B.8 SET-204 TWO-DAY SPECIALISTS’ MEETING ON “WAVEFORM DIVERSITY”, 29/30 SEPTEMBER 2014, BERLIN, GERMANY

Programme

Monday 29 September 2014

Session 0 - OPENING CEREMONY

08:00	REGISTRATION
09:15	OPENING REMARKS Dr Jens Klare , Co-Chair SET-204, FHR (DEU)
09:25	Welcome Speech TBD
09:45	SET Panel Presentation Maj Mauro Roddi , ITA A, SET Panel Executive

Session 1 – Radar Waveform Design/Implementation

10:25	KN1	Overview of Waveform Diversity – 2002 to the present Dr Eric L. Mokole , NRL, USA
11:10		COFFEE BREAK
11:30	1	Novel Twin-Pulse Radar Waveform for Clutter Suppression Prof. Hugh Griffiths , University College London (GBR)
12:00	2	Effects of Modulation Parameters of CPM on the Waveform Spectrum and and Pulse Compression Mr Firat Tigrek , Aselsan (TUR)
12:30	3	Fast-Time Polarization Modulation using PCFM Radar Waveform Prof. Shannon Blunt , University of Kansas (USA)
13:00		LUNCH

Session 2 – Waveform Diverse Systems

14:20	KN2	Waveform Diversity and Design for Radar Systems: Historical Notes, Technical Topics and Way Ahead Prof. Alfonso Farina , Selex (ITA)
15:05	4	Search Radar Architecture using MIMO Transmit Sub-Arrays Mr Timothy Graham , SRC Inc. (USA)
15:35	5	Coupling Effects in MIMO Phased Array M. Laurent Savy , ONERA (FRA)
16:05		COFFEE BREAK
16:25	6	Frequency-Dependent Power Amplifier Modeling and Predistortion in Wideband Radar Transmissions Mr Zachary Dunn , University of Oklahoma (USA)
16:55	7	CW Waveforms for Automotive Diversity Prof. Hermann Rohling (DEU)
19:00		RECEPTION

Tuesday 30 September 2014
Session 3 – Environmentally Aware Waveform Design

09:00	KN3	New Technologies for Spectrum Sharing Between Radar and Communications Systems Dr John Chapin , DARPA (USA)
09:45	8	Waveform Design for Radar Target Recognition with GMM-Based Classifier Prof. Nathan A. Goodman , University of Oklahoma (USA)
10:15	9	Cognitive Synthetic Aperture Radar Prof. Fabrizio Berizzi , University of Pisa (ITA)
10:45		COFFEE BREAK
11:05	10	Game-Theoretic Waveform Strategies in Non-Cooperative Environments Mr Zachariah E. Fuchs , Air Force Laboratory (USA)
11:35	11	Walsh-Hadamard Sequences Implementation for Radar Anti-Jamming Performance Analysis Mr Zdenek Matousek , Armed Forces Academy (SVK)
12:05		LUNCH

Session 4 – Waveform-Diverse Processing

13:20	12	Detection Aided Multistatic Velocity Backprojection Dr Tegan Webster (USA)
13:50	13	Azimuth Ambiguity Suppression in SAR Images using Doppler Sensitive Signals Mr Piotr Serafin , Military Univ. of Technology, (POL)
14:20	14	Adaptive Delay-Angle Processing of Physical MIMO Radar Emission Prof. Shannon Blunt , University of Kansas (USA)
14:50		COFFEE BREAK

Session 5 – MIMO Radar

15:10	15	Adaptive Waveform Design Based on Optimisation Algorithm Dr Vishal Riché , Fraunhofer Institute (DEU)
15:40	16	Performance Analysis of Waveforms for a Collocated MIMO Radar Mr Wim Van Rossum , TNO (NLD)
16:10	17	Modified Noise Waveforms for Ambiguous-free Range-Doppler Sensing Prof. Krzysztof Kulpa , Warsaw University of Technology (POL)
16:40		PANEL DISCUSSION ON WAVEFORM DIVERSITY
17:20		CLOSING REMARKS



Annex C – SUMMARY OF SET-066 REPORT

C.1 INTRODUCTION

The RTO Task Group SET-066 “Frequency Sharing between Communication and Radar Systems” operated from June 2002 to December 2006. Its report was produced in draft form, but never formally issued, and since several of its authors have now retired it is judged to be too difficult to obtain the further contributions and necessary approvals to allow it to be issued. However, since its work and its conclusions are germane to the present Task Group, it has been decided to prepare a short summary of its content and conclusions as an annex to the present report.

No attempt has been made to edit the content and conclusions, other than to trim the length substantially and to present them as clearly and logically as possible. Thus the conclusions are those of the original authors.

The members of SET-066 Task Group were:

- P. Fentem (GBR);
- A.G. Stove (GBR);
- J. Holloway (GBR);
- T. Rutkowski (POL); and
- S. Tessereau (FRA)

C.2 THE NATURE OF THE PROBLEM

The massive explosion in the growth of mobile and fixed wireless telecommunications is resulting in increasing pressure on a limited electromagnetic spectral resource. For example, by the year 2005, there will be in excess of one billion mobile telephone handsets on the plane there is also the expansion of wireless connectivity systems that could dwarf the number of mobile telephones albeit at a lower power and the immanent licensing of ultra-wide-band devices that will be allowed to operate across many currently allocated bands. A major feature for the future growth of wireless telecommunications is an increasing requirement for bandwidth. This will merely exacerbate the pressure on current allocations leading to potential conflicts between military and civil use, both in terms of possible sources of interference to radar systems and the need to restrict radar emissions to prevent interference with other services.

There is a significant difference between the mobile phones, which currently operate within spectrum which is exclusively allocated to them, and for which the pressure on the military is reduction in the spectrum available to them, and the short-range devices such as UWB and wireless LANs, for which the assumption is that they can operate within the same spectrum as the military users, (as secondary allocations?) without causing interference, but of course these will result in some increase in the receiver noise level, and the question is whether this increase is really insignificant.

The economic case put by the telecommunications industry is likely to result in further erosion of radar allocations as well as placing demands on the spectral output and purity of radar systems. Currently the most immediate potential conflict is caused by the telecommunications industry seeking further bandwidth allocations at around 3 GHz where there are military radar systems. Whilst the allocation of new bands for 3G mobile telephones in S-band was postponed at WRC 2000 as the industry recovers from the down turn the pressure form more frequency in third region will return. At WRC 2003, in order to obtain some protection for military radio location, a proposal was adopted to upgrade this service to co-primary with aeronautical radio navigation in the band 2.9 to 3.1 GHz.

ANNEX C – SUMMARY OF SET-066 REPORT

Already band sharing in the 2.7 to 2.9 GHz band has been approved by CEPT with Europe on a non-interference basis for ENG/OB cordless cameras and aeronautical telemetry.

There are five potentially very significant problems for the military:

- 1) The first is that the civil systems themselves may interfere with the military radars reducing military capability.
- 2) The second is that if military systems are interfering with civil systems then they may require modification resulting, possibly, in a reduced capability.
- 3) Thirdly, it is possible that bandwidth currently allocated to the military may be changed to civil usage with even more serious implications for radar system performance. It is highly likely that part of the military radar bands will be re-allocated to the civil community.
- 4) A fourth problem is that any alteration to military radar systems is likely to have serious cost implications.
- 5) Finally, future military applications such as counter stealth may require increased use of spectrum or need to use spectrum currently allocated to civilian use.

The following are characteristic examples of the conflicts which arise between the requirements of military radars and civilian communication systems.

Military radars are typified by high transmit powers which, in communications terms, leaves unacceptable power levels out-of-band. This may cause interference forcing modifications to the radars. This is just when the military requirements are themselves demanding wider bandwidths for applications such as Imaging, NCTR, ATR and ballistic missile defence.

Some radar systems home on jamming sources and may mistake a communications transmitter for a jammer.

UHF and VHF frequencies offer the following significant military advantages:

- Countering stealth technology;
- Penetration of foliage and ground; and
- Detection of difficult targets (such as hovering helicopters).

These frequencies are currently in communications bands and thus methods for harmonious operation will have to be developed if the military advantage is to be realised. It would not be practical for major sections of the spectrum in this area to be allocated exclusively to radar, but if techniques can be evolved to allow other bands to be shared, these may, in turn, be able to be used to allow additional allocations for radars in these bands.

This activity of this SET has built on the work previously carried out by the exploratory team. National allocations of the EM spectrum had already been partially documented and some regions likely to lead to interference identified. Some examples of interference between civil and military systems had been estimated to highlight the potential seriousness of this problem.

C.3 OBJECTIVES

The overall objectives for the SET-066 programme of work were therefore stated to be:

- 1) To quantify the performance of military systems under conditions of interference due to proposed re-allocation of the electromagnetic spectrum.

- 2) To assess the effects of system performance changes on military capability.
- 3) To propose methods to evaluate the likely levels of interference between civil and military electromagnetic systems.
- 4) To evaluate possible technology solutions to allow systems to work in the same part of the electromagnetic spectrum.
- 5) To consider the implication of new COTS wireless communication schemes.
- 6) To review the possible impact of the allocation of frequency masks for UWB devices.
- 7) To provide inputs for use by other NATO areas in discussions pertaining to the next WRC in 2007.

C.4 REPORT STRUCTURE

The sections in the report were:

- 1) Introduction.
- 2) Objectives.
- 3) Mechanisms which cause interference between military radar and civil telecommunications.
- 4) Potential techniques to overcome interference mechanisms.
- 5) Consideration of the effects of proposed changes in the spectrum on a selection of generic radar military types.
- 6) Civil communications and ‘UWB’ in particular.
- 7) Conclusions and Recommendations.
- 8) Proposal for Further Study:
 - Annex A: Band allocation tables;
 - Annex B: Detection probability;
 - Annex C: Filter design techniques;
 - Annex D: Antenna techniques; and
 - Annex E: Characteristics of radars.

C.5 MECHANISMS WHICH CAUSE INTERFERENCE BETWEEN MILITARY RADAR AND CIVIL TELECOMMUNICATIONS

C.5.1 Challenges Imposed on Radar Services

C.5.1.1 Current Environment

In the past, radar systems have been robustly designed to deal with low-level interference from established transmission equipment and the spurious outputs from neighbouring radar systems. However, the increases in the implementation of communication links have introduced the possibility of degradation to radar system integrity and overall performance.

Currently, the spectral environment is populated by many and varied systems, including mobile/personal communications and GPS/GLONASS, and potentially Galileo satellite navigation systems, and a multitude of military and civil radar systems. To this end, each system allocated to a particular frequency is required to adhere to specific rules of transmission to ensure that they do not interfere with a cohabiting system.

Current radar system installations are spectrally located so as not to cause service degradation to co-habitant radar systems via transmitted interference. However, a maturing personal communications industry has introduced possible interference sources that could, if not studied, monitored and analysed, cause harmful interference to a victim radar system and reduce its performance below that required by the user.

The current regulatory communities have declared that such an interference signal should reside no more than -6 dB from the victim radar receiver noise floor. At this level, the interfering signal is deemed a suitable distance from the victim receiver noise floor so as not to cause unacceptable degradation to the performance of the radar system. However, this subject matter is under much discussion as it is not based on any objective evidence and takes no account of the role and permissible degradation of the radar being used.

One such paper discussing radar system performance degradation through cohabitation of GPS RNSS (Radio Navigation-Satellite Service) and radar systems in the 1215 – 1300 MHz Band is given in Ref [1].

Current technical challenges involve determining how transmitted interference affects individual radar systems, evaluating the effects such interference would have on the radar system's ability to maintain the required level of service and investigating the introduction of alternative methods of reducing the effect of current interference signals.

However, a significant obstruction in assessing the current spectral environment is quantifying the degrading effect of the interference on the victim radar system. For high-level interference, the effect is generally obvious to an operator using a pseudo-analogue display however increasingly radars are used with synthetic displays and automatic plot extraction and tracking in such system the presence and effects caused by interference may not be immediately obvious. However, due to the very nature of radar (detecting weak signals in all conditions), it is difficult to gain hard evidence that any degradation witnessed is caused by interference at or below the receiver noise floor.

This situation is exacerbated by the following facts:

- Each radar system has its own set of individual mission requirements.
- Each radar system is required to operate in a different environment (terrain, weather conditions, etc.).
- Each radar system has its performance requirements specified by the end user, not the designer.

These factors indicate that each individual radar system may behave in a different manner when presented with the same interference signal, thus, generating inconsistent and invalid evidence.

C.5.1.2 Future Environment

The future of the radio spectrum when considering radio location services is somewhat unclear. The assessment of this perceived situation is complicated, to say the least. For many years, radar has maintained its primary position within the radio spectrum, occupying significant areas of the available bands. However, this situation may have to be revised, as it is quite clear that radar frequencies are under threat from the many and varied communications systems making their way into the world.

An added threat is the future use of wideband/ultra-wideband systems that may be licensed for use in bands currently used by radars under the preconception that their power is so low as to not cause problems with existing users. Such systems have the effect of raising the thermal noise or noise temperature – this can have an effective of reducing the radar's sensitivity in a noise-limited environment. The important question, however, is whether this reduction is significant.

This phenomenon should be assessed in the following ways:

- Technical Reasoning.
- Economic Reasoning.

C.5.1.3 Technical Reasoning

Notwithstanding the slow take-off of third-generation (3G) GSM systems, the communications sector is one of growth, and continues to grow at an undefined rate. In the developed world, the market for basic mobile phones (cell phones) must be approaching saturation, but there is an ever-increasing demand for bandwidth for applications such as video. In other parts of the world, the sheer number of devices is still increasing rapidly.

The need for communications comes, potentially, at a high cost, especially to the radar user community. It is envisaged that the communications sector will continue to push for higher bandwidth to support future trends, higher data rates and, due to the target frequencies, this could impact and impinge on the bandwidth utilised by neighbouring radar systems.

In the future this impact may become evident to the radar community in a number of ways:

- Radar services currently enjoying primary status may be re-assigned to co-primary or secondary with communication services.
- Bands currently allocated only to radar may be opened up to allow communications services to share as secondary or co-primary.
- Parts of the currently allocated radar bands may be re-allocated to communications systems.

In the first two cases, the radar systems will operate in an environment where interfering signals may be competing with the radar target returns. Depending on the nature and strength of these interference signals, the radar will be faced with a number of protection challenges. These cases will need to be the subject of future possible sharing studies.

In the third case, the spectrum availability is reduced while the required number of operational radar systems is unlikely to be reduced. This could lead to more crowding and radar systems are then more likely to suffer interference from other radar systems than from communication systems.

C.5.1.4 Economic Reasoning

The future will bring many challenges for radar on an economic front. Services that utilise the future spectrum must consider the following four topics with care, as they will impact on the economic constraints of any service:

- The amount of required bandwidth for the system;
- The efficiency of the system;
- The amount of value gained per Hz of bandwidth within the system; and
- The amount of identifiable redundancy within the system.

The required bandwidth is mostly dependent on the range-resolution requirement of the radar and is thus central to the customer requirement definition process.

The second topic relates to the amount of bandwidth needed to maintain an efficient system. This topic will become extremely important in a market-driven environment, as the price of spectrum increases through demand. It is envisaged that the price of spectrum and bandwidth will increase as the number and variety of communications systems continues to increase. Such a market-driven environment is currently being

encouraged in the UK by the regulator, Ofcom, following the pioneering approach of Australia and New Zealand. There is every likelihood that such an environment could also replace the historical ‘Command and Control’ environment in other countries in which NATO operates.

This will place extreme pressure on radar services to compete on a bandwidth and efficiency level with the communications sector. The unfortunate truth is that the communications sector, being of a commercial nature, can provide a high revenue for a smaller spectral allocation as opposed to the commercial radar service that requires a larger bandwidth for less return. This is not favourable to the operation of a radar service.

The third topic places a value on the information content present per Hz of the leased bandwidth. Information (or lack of it) is of particular importance to the successful operation of a radar service. When a pulse is transmitted, the information value of that pulse is high, whether it detects a target or not.

This leads to the observation that all radar transmissions provide valuable information. The fact is that a transmission that detects no target is equally as informative as a transmission that detects a target.

The fourth topic encompasses the ability of the radar service to be streamlined through redundancy identification. For example, in communications system waveform design, redundancy is identified at an early stage. This enables bandwidth requirements to be reduced. In a radar system as most information is required at all times, this does not leave much room for redundancy.

The analysis of these topics will provide great insight into the economic aspects of future systems. Bandwidth will be at a premium and the most efficient services will be viewed as the most favourable for allocation. Services that provide poor efficiency, cannot demonstrate good information value per Hz and cannot limit their required bandwidth could be put at a financial disadvantage.

This probable future scenario means that the radar community must move ahead with research into ways of improving systems spectral efficiency in order to remain in competition with the communications sector and to conduct sharing studies to evaluate the effect of possible sharing of frequency bands with communication systems.

C.5.2 The Nature of Interference

In order to discuss the mechanisms that cause interference between radar and communications, we need to consider the nature of the interfering signal. The effects of interference on a radar can be:

- Transitory (only occurs when interfering signal is present).
- Temporary (exists after the interference has been removed, i.e., recovery or reset).
- Permanent.

Which of these effects occurs depends on several factors:

- The level of the interfering signal.
- The period of the interfering signal.
- The nature of interfering signal.

The effect the interference has on the performance of the victim radar system however depends not only on the above, but also on the operation and configuration of the victim radar system itself. Its antenna, receiver and signal processing all play a part in how the system reacts to interference and whether the interference causes a problem in terms of overall operation of the system.

When assessing the effect of interference it is necessary to know the level of the interfering signal received by the victim radar system.

- 1) The signal strength incident on the victim system which is related to the:
 - Absolute power or more accurately EIRP of the interfering transmissions;
 - Distance between the interferer and the victim;
 - Propagation conditions;
 - Geographic screening; and
 - Spatial screening.
- 2) The ability of the victim to “receive the signal efficiently”, which is affected by the following attributes of the interfering signal:
 - The frequency;
 - The bandwidth;
 - The polarisation; and
 - Antenna factor.

Once received by the victim when assessing effect that the interference has on the operation of the victim radar it is necessary to know:

- The final signal level received; and
- The modulation or coding on the signal.

When considering how sensitive the a victim receiver is to interference from a specific type of interference sources it best to initially to ignore the propagation effects and the distance the source is from the radar as these are generally outside the control of the victim and to characterise the interference in terms of incident field strength or power density.

Once the sensitivity has been established then issues of sighting and propagation can be considered.

Interference which enters other than through the antenna part is normally a short-range effect and should not be a problem for a well-designed radar faced with the levels of interference which could arise from a mobile phone, much less from a short-range device.

There are two basic methods by which a victim radar receiver can receive interference. These are:

- Interference through the antenna port of the receiver; and
- Interference not through the antenna port of the receiver.

Interference which enters other than through the antenna part is normally a short-range effect and should not be a problem for a well-designed radar faced with the levels of interference which could arise from a mobile phone, much less from a short-range device.

There are three distinct cases that need to be considered:

- “In-Band” – The necessary band of the victim receiver lies wholly within the necessary bandwidth of the radar-transmitted signal.
- “OOB” – The necessary band of the victim receiver lies wholly or partially with in the OOB region of the radar-transmitted signal.

- “SE-Band” – The necessary band of the victim receiver lies wholly in the SE region of the radar-transmitted signal or where the victim receiver has a spurious pass-band that lies in any of the three regions of the interfering signal.

C.5.2.1 In-Band Interference

In band interference is when the pass band of the victim receiver is fully within the necessary bandwidth of the transmitted signal.

The features that affect the level of interference received and the effect it ultimately has on the victim radar system in this case is:

- Incident field strength;
- Radar selectivity;
- Receiver linearity;
- Frequency offset;
- Polarisation;
- Modulation or coding used in the radar; and
- Radar receiver mode of operation.

C.5.2.2 Out-Of-Band (OOB) Interference

Out-of-band interference is when the pass band of the victim receiver is fully or partially within the OOB region of the transmitted signal.

The features that affect the level of interference received and the effect it ultimately has on the victim radar system in this case is:

- Incident field strength;
- Radar selectivity;
- Selectivity (spectrum) of interference source;
- Receiver linearity;
- Frequency offset;
- Polarisation;
- Modulation or coding used in the radar; and
- Radar receiver mode of operation.

C.5.2.3 Spurious Band Interference

Spurious band interference is when the pass band of the victim receiver is fully or partially within the spurious region of the transmitted signal.

The features that affect the level of interference received and the effect it ultimately has on the victim radar system in this case is:

- Incident field strength;
- Radar selectivity;
- Spurious emission limits of interference source;

- Presence of spurious pass-bands in victim receiver;
- Receiver linearity;
- Frequency offset;
- Polarisation;
- Modulation or coding used in the radar; and
- Radar receiver mode of operation.

C.5.3 Features that Affect the Interference Seen in the System

C.5.3.1 Incident Field Strength

The electric field present on the victim radar can be one of two types:

- Continuous; and
- Pulsed.

In continuous interference the signal is always present in one form or another it may vary in amplitude or appear noise-like, CW is the simplest form continuous interference.

In pulsed interference the signal has a distinct on and off cycle with a fixed or variable PRF. Digital communications signal whilst they contain pluses generally look like continuous interference to radar receivers.

There are two factors that can be used to define the level of the signal:

- The peak power; and
- Spectral power density.

The peak power is the maximum excursion of the signal however to peak power needs to be expressed in given bandwidth if the full power is to be received. The peak power can be related directly to the peak rms electric field strength E_{rms} for a plane wave using the following formula:

$$E_{rms} = \sqrt{(P_{pk} \times \zeta_0)} \quad (C-1)$$

where P_{pk} is peak power
 ζ_0 is the impedance of free space = 120π Ohms

The spectral power approximates to the mean power / occupied bandwidth.

C.5.3.2 Radar Receiver Selectivity

The radar's necessary bandwidth is the bandwidth required to operate to the required level of distortion. Generally this is the IF bandwidth of the radar and is set by the IF filtering in the system. The selectivity of the radar receiver is the ability to reject signals outside of the IF bandwidth. In a superhet receiver the radar may have more than one IF stage and each stage may have a different selectivity this needs to be considered as each IF stage may have active components where the linearity may depend on the distance that the interfering signal is away from the radar's nominal operating frequency.

We also need to understand the different between operational bandwidth and necessary bandwidth when considering front-end blocking. Many multi-frequency radars have a much wider operating bandwidth than their necessary bandwidth this allows them to be frequency agile or operate on multi-frequencies. This is generally accomplished by having a wide RF bandwidth inside which the radar has many operational channels selected by the use of an agile frequency source. Any active complements in the wide operational bandwidth can be potentially overloaded by signals well outside the necessary bandwidth over which the radar receiver is operating.

C.5.3.3 Spurious Emission Limits of Interference Source

As well as radiating over its necessary bandwidth the interfering source also radiates spurious emissions if these fall with the radars bandwidth then they can cause interference.

C.5.3.4 Presence of Spurious Pass-Bands in Victim Receiver

As well as receiving within its necessary bandwidth the radar may have spurious receiving bands these may be associated with image frequencies within the superhet receiver. If the interference falls within such a band the victim radar can receive it. Spurious emissions from the source may also fall within these spurious pass bands.

C.5.3.5 Radar Receiver Linearity

The linearity of the receiver determines how the interference affects the system if the interference causes the receiver to go non-linear then it can produce modulation effects within the receiver or can lead to blocking of other signals.

C.5.3.6 Interference Frequency Offset

The offset in frequency between the radar receiver and the interference also determines the effect the interference has on the system. The level of the effect is related to the selectivity of the victim receiver.

C.5.3.7 Polarisation

The polarisation mismatch between the radar and the interference affects how much of the interference is received. In Table C-1 the ideal polarisation matrix is shown.

Table C-1: Polarisation Loss Ideal.

Source	H	V	RHCP	LHCP	SL +45	SL -45
Victim						
H	0	∞	3	3	3	3
V	∞	0	3	3	3	3
RHCP	3	3	0	∞	3	3
LHCP	3	3	∞	0	3	3
SL +45	3	3	3	3	0	∞
SL -45	3	3	3	3	∞	0

Whilst the theory shows that high levels of isolation can be achieved for cross-polar reception, in practice the best-designed system can only achieve 20 dB isolation for direct line of sight with identical antennas.

C.5.3.8 Modulation or Coding Used in the Radar

The effect that interference has on a system also depends on how the modulation of the interfering signal is demodulated (decoded) by the victim radar. It thus depends on the nature of the modulation used by both systems.

One example of how coding can modify the effect of the interference comes from the area of communications. Many communications systems use coding schemes that allow wanted signals to be recovered from amongst many others, from similar systems operating on the same frequency. Such code division multiplex systems make use of so-called orthogonal codes where one system does not receive interference from other codes.

A second example is pulse compression coding, in the example shown non-linear FM sweep is used to expand the transmitted signal on reception the pulse is compressed to a pulse length equal to $1/Bw$ where Bw is the chirp bandwidth.

The compressed pulse is shown in Figure C-1. The figure shows the output of the pulse compressor to a correctly coded pulse. In this example, the compressor has a compression ratio of 19 dB.

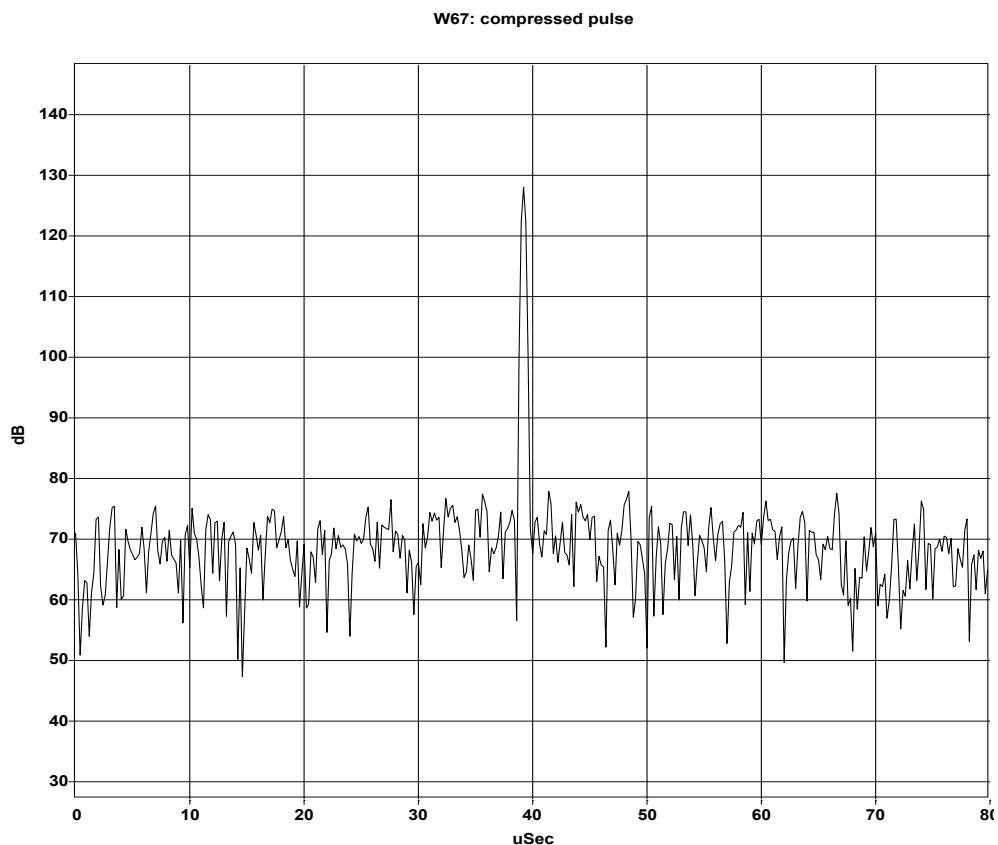

Figure C-1: Output of Pulse Compressor Matched Waveform.

The effect of pulse compression on signals and noise is well known. When a matched pulse is passed through the compressor, the signal-to-noise ratio at the output is increased with respect to the signal-to-noise

ratio at the input. The improvement in signal-to-noise ratio across the compressor is the compression ratio and so will vary with the detailed design of the radar. In order to circumvent this, the interfering noise being defined with respect to the radar system noise. By doing this, it is not necessary to take account of the pulse compression when assessing the effect of interfering noise so long as both are measured at the same point and in the same bandwidth.

In other words, interfering noise which is equal to system noise before the compressor will also be equal to system noise after the compressor.

The exact form of interference is not known. However as an example, if phase or frequency shift coding is used, then the waveform will look like short bursts of a continuous wave signal and the effect of pulse compression will be quite different to the effect on noise, pulse compression spreads unwanted signals by the uncompressed pulse length.

Figure C-2 shows the output of the compressor when the input is a CW pulse of the same length as the matched pulse. Comparing the height of the outputs shows that the CW pulse is reduced, compared to the coded pulse, by about 13 dB. However, since the gain of the matched pulse is 19 dB, this shows that a CW pulse also receives some gain through the compressor, in this case about 6 dB. The result is that the effect of bursts of CW will be worse than if the interfering signal is white noise.

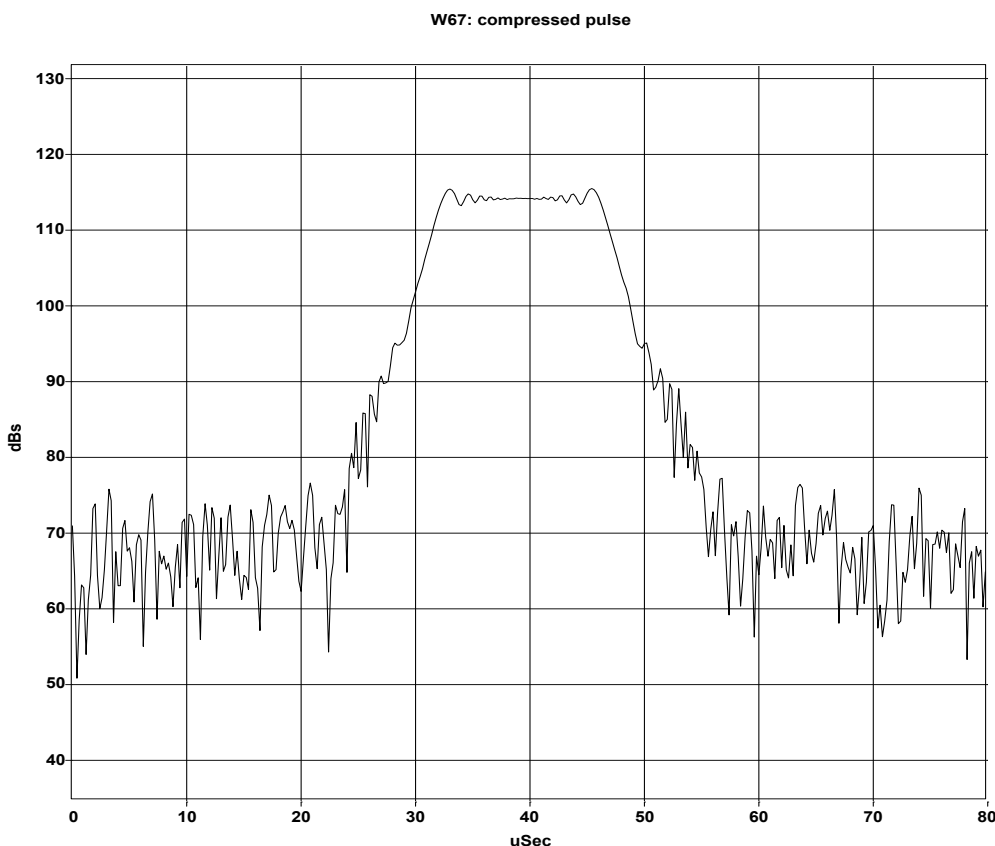

Figure C-2: Output of Pulse Compressor Partially Matched Waveform.

It should also be noted that as well as experiencing some compression gain, the signal is spread over many range cells this could affect the background averager or CFAR causing the radar to be desensitise over a larger extent in range than if the interfering signal had been fully compressed.

C.5.3.9 Radar Receiver/Processor Mode of Operation

The mode in which the receiver/processor operates can also determine the effects of any interference that is present. To illustrate this, consider a simple video-based radar receiver/processor which operates in a pulsed mode on reception. It is common in military radars to incorporate circuits that synchronise the detected replies to the radars PRF. Such circuits, known as PRF decimators or “defruiters”, reject any signals that are not using the same PRF as the radar. This has the effect of reducing asynchronous pulsed interference and hence reduces the number of false alarms seen on the display. More modern radars that make use of AMTD or MTI make use of several pulses to determine the velocity of the target this type of processing also has the effect of reducing asynchronous interference. However to get a full picture of what the processing does in the presence of asynchronous pulses it is necessary to carry out a full analysis.

In the presence of other types of interference or interference of a similar type with different parameters the receiver and signal processor may react in a different way, so each case must be assessed individually.

C.5.4 Initial Considerations of Interference Mechanisms in the Radar Receiver

C.5.4.1 Consideration of Interference-to-Noise Ratio I/N

A radar receiver is designed to detect a specific minimum returned signal power at a specified maximum range; this value denotes the sensitivity of the radar over the bandwidth specified.

Radar receivers are designed to provide the maximum sensitivity whilst producing the minimum amount of internally generated noise. If an external noise source is injected into the receiver, then the receiver noise floor increases accordingly; this has the effect of reducing the sensitivity of the receiver.

However, the externally generated noise does not necessarily have to reside above the receiver noise floor to contribute to loss of sensitivity it can cause a significant level of degradation even if it resides below the noise floor.

The probability with which a radar can detect a target of a given size depends on the S/N . An initial consideration of the radar equation shows that the signal received for a given range is given by the following equation:

$$S = \frac{P_t G_t^2 \sigma \lambda^2}{(4\pi)^3 R^4 L_{tot}} \quad (C-2)$$

If the interference has the effect of desensitising the radar this increases the noise power in the radar, to maintain the S/N the signal strength needs to be increased. To accomplish this, the range has to be reduced to recover the detection probability.

Current ITU recommendations specify that an I/N of -6 dB is a safe margin so as not to degrade the sensitivity of radar services. However, it has been suggested that this value should be reduced further to -10 dB for SOL services. The example below demonstrates the effect on maximum range when I/N is increased.

C.5.4.2 L-Band Range Reduction Caused by Variation in I/N

The following example shows the effect that varying I/N values have on an L-band radar. The example has been calculated using the basic single-pulse radar range equation:

$$R_{\max}^4 = \frac{P_t G_t^2 \sigma \lambda^2}{(4\pi)^3 N (S/N) L_{tot}} .m \quad (C-3)$$

- where: P_t = Peak transmitted power (W)
 G_t = Total antenna gain
 σ = Target radar cross-section (m²)
 L_{tot} = Total overall loss
 S/N = Minimum signal-to-noise ratio for detection
 λ = Wavelength (m)
 N = Receiver noise floor (W)

Table C-2 shows the effect that increasing noise floor has on the maximum operating range of the radar.

Table C-2: The Effect of Increasing Noise Floor on the Maximum Operating Range.

<i>I/N</i> (dB)	Range (km)	Loss (km)	% R_{\max} Reduction
IDEAL	161.016	N/A	N/A
-20	160.616	0.400	0.248
-10	157.225	3.791	2.355
-6	152.244	8.773	5.448
-3	145.466	15.550	9.658
0	135.398	25.618	15.910
3	122.394	38.622	23.986
10	88.414	72.602	45.090

The appropriate value of loss introduced by the I/N has been added to the system loss in this particular case, so that:

$$L_{tot} = L_{sys} + L_{int} \quad (C-4)$$

- where: L_{tot} = Total overall loss
 L_{sys} = Total system loss
 L_{int} = Loss due to interference

It can be seen that at the ideal (no external interference) the maximum range is 161 km.

If the I/N value for this example is defined as -6 dB, a reduction in range of approximately 9 km is witnessed, leading to a maximum range of 152 km. Compare this value of reduction to that of an I/N of -10 dB, which leads to a range reduction of only 4 km from ideal.

C.5.4.3 Hostile Source Transmit Power Required to Cause Range Reduction

In practical situations, the interference present in the victim radar receiver is transmitted from an external source, and is treated as ‘hostile’ interference. The equation below can be used to calculate the minimum effective transmitter power required from a hostile interference source so as to inflict the I/N values already calculated in the example above.

$$P_t = \frac{P_r (4\pi R)^2 L_{tot}}{G_t G_r \lambda^2} \text{ kW} \tag{C-5}$$

- where:
- P_t = Peak transmitted power (kW)
 - P_r = Power received (kW)
 - G_t = Transmit antenna gain
 - G_r = Receive antenna gain
 - L_{tot} = Total overall loss
 - λ = Wavelength (m)
 - R = Range (m)

The first portion of this example assumes that the hostile interference source is located at the maximum range of the victim radar system, i.e., 161 km and that the victim radar system has the same parameters as the previous example.

Figure C-3 shows, that to maintain an I/N of -6 dB, at a range of 161 km, the hostile transmitter must produce -41.85 dBW in the radars bandwidth. This will inflict an interference level of -156.98 dBW on the receiver within the victim radar system. This analysis is expanded to include a selection of I/N values (from -20 to $+10$) and the powers required to maintain them, as shown in Table C-3.

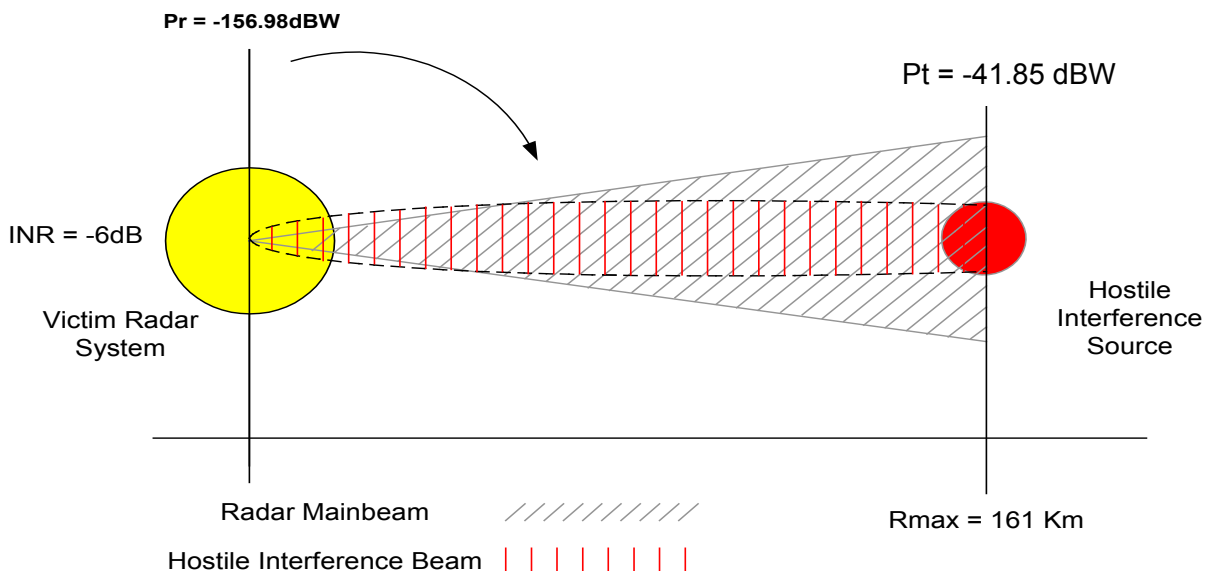

Figure C-3: Effective Power at Victim Radar Receiver When Transmitted from a Hostile Interference Source.

Table C-3: I/N and the Powers Required to Maintain them with Interferer at 161 km.

Hostile Transmitter 161 km Distance from Victim		
Equivalent I/N (dB)	Hostile Transmit Power (dBW)	Power Level at Victim Rx (dBW)
-20	-61.85	-170.98
-10	-45.85	-160.98
-6	-41.85	-156.98
-3	-38.85	-153.98
0	-35.85	-150.98
3	-32.85	-147.98
10	-25.85	-140.98

In the second portion of this example shown in Table C-4, the hostile interference source is moved closer to the victim radar system – in this case 1 km.

Table C-4: I/N and the Powers Required to Maintain them with Interferer at 1 km.

Hostile Transmitter 1 km Distance from Victim		
Equivalent I/N (dB)	Hostile Transmit Power (dBW)	Power Level at Victim Rx (dBW)
-20	-105.98	-170.98
-10	-89.98	-160.98
-6	-85.98	-156.98
-3	-82.98	-153.98
0	-79.98	-150.98
3	-77.98	-148.98
10	-69.98	-140.98

As can be seen, the power transmitted need not be so great at the distance of 1 km to induce the same range degradation as before. In this case, to inflict an I/N of -6 dB, the transmitter power of the hostile interference source need only be -85.98 dBW.

C.5.4.4 Variation in Detection Probability (P_d) Due to Variation in I/N

The previous treatment of the I/N problem has taken into account that the S/N must remain at the required system level, and is held constant throughout the analysis. One alternative method of treatment would be to introduce the varying I/N value and to monitor the decrease in detection probability, whilst attempting to maintain a given false alarm probability (P_{fa}).

To perform this analysis, the same L-band radar parameters will be used, assuming a fixed detection range at R_{max} of 161.016 km and a fixed P_{fa} of 10^{-6} . The equation for this analysis is a transposed version of the radar range equation, as shown below:

$$S/N_{dB} = 10 \times \log_{10} \left(\frac{P_t G_t^2 \sigma \lambda^2}{(4\pi)^3 N R_{max}^2 L_{tot}} \right) \quad (C-6)$$

(all parameters are as before).

In this case, the I/N value is once again added to the system loss to produce a total loss (L_{tot}). The table of results for this equation is shown below.

Table C-5: I/N vs. S/N .

I/N	$S/N(\text{dB})$	I/N	$S/N(\text{dB})$	I/N	$S/N(\text{dB})$
Ideal	12.983	1	9.444	-10	12.569
		0	9.973	-11	12.651
10	2.569	-1	10.444	-12	12.717
9	3.468	-2	10.859	-13	12.771
8	4.344	-3	11.219	-14	12.814
7	5.193	-4	11.528	-15	12.848
6	6.001	-5	11.790	-16	12.876
5	6.790	-6	12.010	-17	12.897
4	7.528	-7	12.193	-18	12.915
3	8.219	-8	12.344	-19	12.929
2	8.859	-9	12.468	-20	12.940

These results show that the S/N is drastically reduced as the I/N value increases.

The variation in S/N can now be used to predict the effect on P_d whilst attempting to maintain a defined P_{fa} . This is achieved through the use of a standard probability graph. This graph demonstrates the relationship between S/N , P_{fa} and P_d .

Table C-6 shows the results of a selection of approximate P_{dS} , using the S/N values shown in the tables above.

Table C-6: I/N , S/N , P_d and P_{fa} (Constant P_{fa}).

I/N	S/N	P_{fa}	P_d
Ideal	12.983	10^{-6}	0.85
-10	12.569	10^{-6}	0.75
-6	12.010	10^{-6}	0.60
0	9.973	10^{-6}	0.24
6	6.010	10^{-6}	0.01

This shows that for an I/N of -6 dB the resultant S/N is 12.010 dB. When the P_{fa} is held to a constant, the detection probability is affected. In this case, the noise-like interference signal has caused the S/N to reduce by 1 dB, which in turn has reduced the probability of detection from 0.85 to 0.6.

Another alternative method of demonstrating the effect of I/N is again to analyse how I/N affects S/N , but in this instance hold P_d constant and monitor the variation on P_{fa} , for a given fixed R_{max} .

This example assumes that the value of R_{max} is fixed at 161.01 km and that the P_d to be maintained is 0.85. Any variation in I/N will cause a proportional variation in the P_{fa} . As the effect of I/N has already been calculated there is no need to repeat the calculation.

Using the standards probability graph, the variation in P_{fa} can be seen for a constant P_d . Selected approximate values of P_{fa} have been provided in Table C-7.

Table C-7: I/N , S/N , P_d and P_{fa} (Constant P_d).

I/N	$S/N(\text{dB})$	P_d	P_{fa}
Ideal	12.983	0.85	10^{-6}
-10	12.569	0.85	10^{-5}
-6	12.010	0.85	10^{-4}
0	9.973	0.85	10^{-3}
6	6.010	0.85	10^{-1}

This shows that an I/N value of -6 dB results in an S/N of 12.010 dB. This causes the P_{fa} value to increase from 10^{-6} to 10^{-4} . The result of this is to decrease the amount of time between each detected false alarm.

Another method of addressing the degrading effect of I/N , and involves the increase of the minimum detectable RCS, at a given range, experienced by a victim radar system when the system noise is increased by an external interference source.

Assuming ideal conditions, if the victim radar receiver has no external interference applied to it, then the radar will detect, at maximum range, a target with the minimum specified value of RCS.

However, now assume that an external noise source has been introduced to the victim radar receiver, thus causing I/N to increase. In order to maintain the maximum detection range, the minimum value of RCS must increase. The result of this action is that smaller targets fail to be detected in favour of maintaining maximum detectable range.

It should be noted that the above data assumes that the target is not fluctuating. For a slowly-fading target the data will be different, however the design of the radar processing will generally be such as to suppress the effects of the variation in fading characteristics, so that the overall performance will approximate the behaviour of non-fluctuating targets.

C.5.4.5 Receiver Blocking

If the signal is large enough to drive the victim receiver into a non-linear region then this can cause the receiver to become blocked, i.e., it cannot receive any signals for the duration of the interference. If the interference is continuous then the blocking will last as long as the interference is present.

If the interference is pulsed then it will last as long as the interfering pulse is present plus the recovery time of the system. The recovery time is a function of the specific device in the system that has been driven into its non-linear region and how far into limit it went.

The result will be that in the direction of the blocking signal the radar loses sensitivity. Figure C-4 illustrates the effect of blocking occurring in an ATC radar.

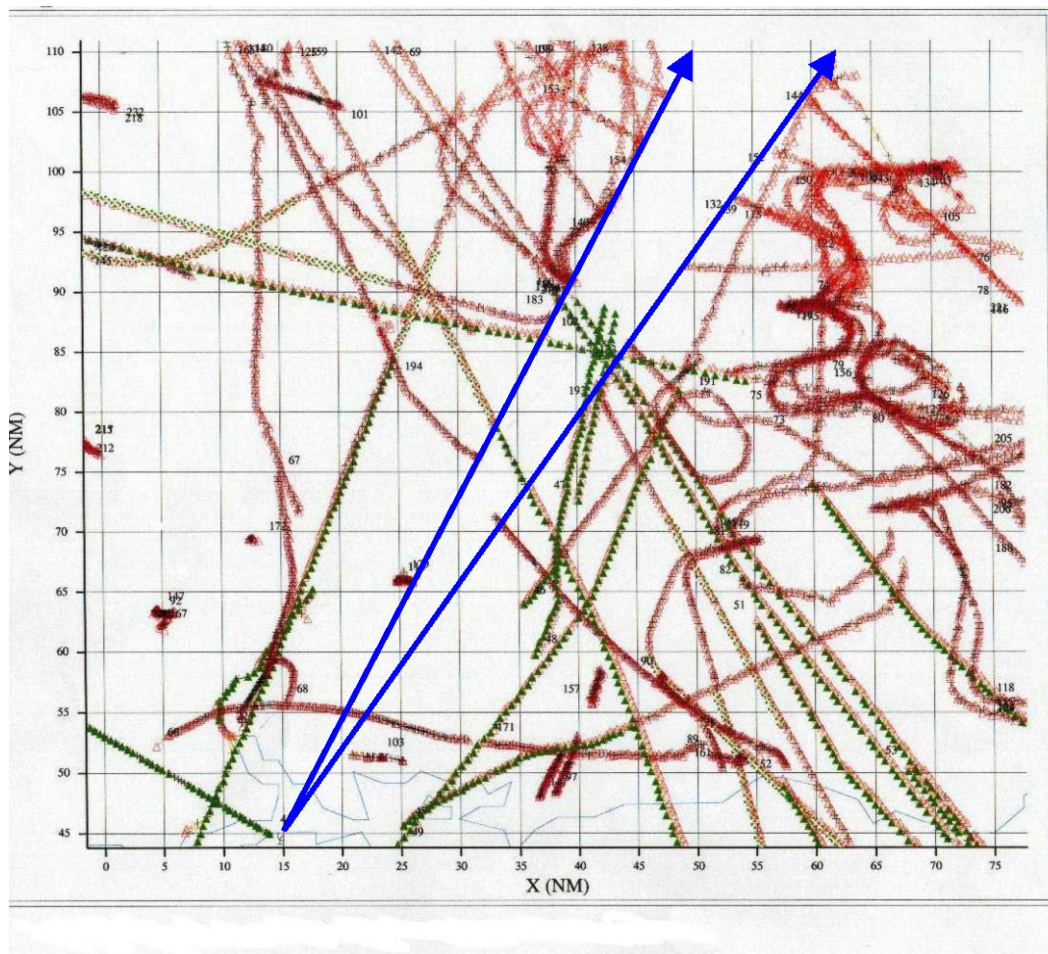

Figure C-4: Effect of Loss of Sensitivity on Radar Detections.

This shows the effect of an I/N ratio of 19 dB that strictly speaking is not true blocking. In this case the effect is due to the CFAR system desensitising the radar. However the effect of blocking would be the same.

The red crosses are primary radar detections, the green triangles secondary radar. As can be seen, the targets are lost in the region of the interference which is bounded by the blue arrows. It will be noted that the defects seen within that region are all from the secondary radar.

C.5.4.6 Range Accuracy

The effective output of the matched filter is the ratio of the root mean squared mean power to the noise ($2S/N$), where S/N is the power signal-to-noise ratio and is the criterion for detection applied to all radars.

It is possible to conceive how the output could be connected to an oscilloscope type display with the time axis triggered by the radar, say the transmit pulse. The resulting display would look like Figure C-5.

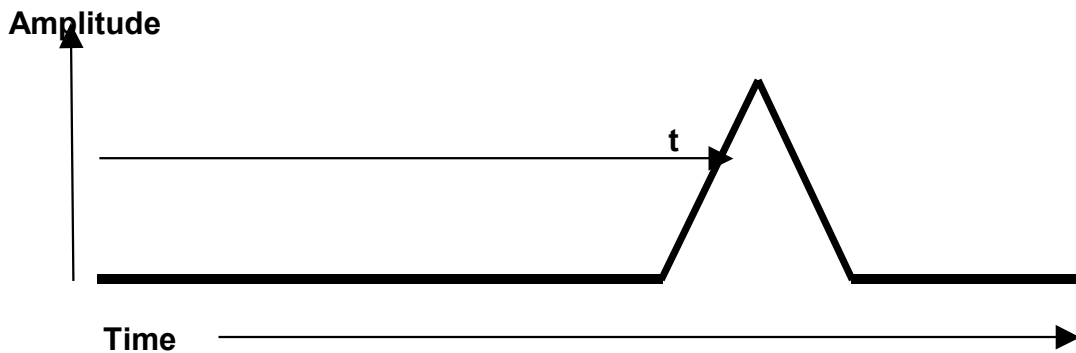

Figure C-5: Idealised A-Scope Trace.

This type of display is called an A-scope and in this display the range of the target is proportional to the time on the display.

$$R = \frac{ct}{2} \tag{C-7}$$

There is a need to define a threshold at which point detection is said to occur. We may define it as the peak however it is more common to choose some defined level, or threshold above the ambient-noise level. In radar plot extractors it is usual to define a threshold crossing.

In this case then the range accuracy depends on two factors:

- How accurately we can measure the reference or threshold crossing point.
- How accurately we can measure time.

The threshold crossing measurement is subject to system noise. Figure C-6 illustrates the problem.

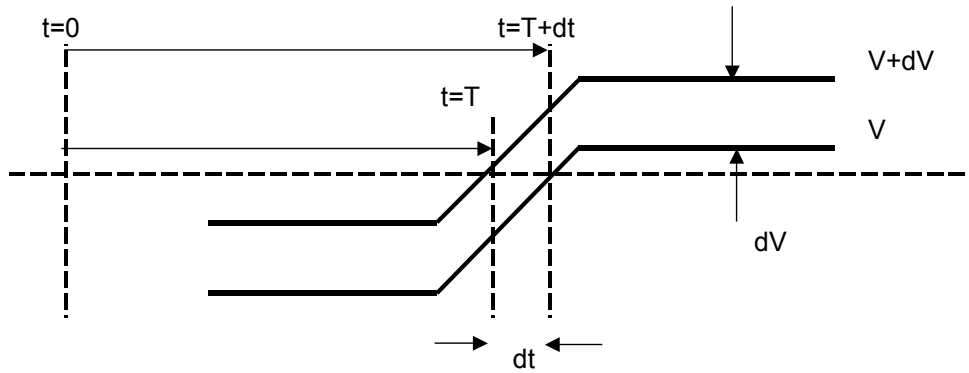

Figure C-6: Noise Effect in Threshold Crossing.

The figure shows a threshold crossing measurement. The voltage of the pulse is V , however noise causes the signal to rise to $V + dV$ causing the measured time of the reply to fall from $T + dt$ to T , thus giving a measured reduction in range. It can be shown for a single pulse that the error in measuring the range due to S/N is:

$$\delta_R = \frac{c\tau}{4 \times \sqrt{S/N}} \quad (C-8)$$

where τ is the pulse length and c the speed of light.

The equivalent equation for a compressed pulse is:

$$\delta_R = \frac{c\tau}{4 \times \beta \sqrt{S/N}} \quad (C-9)$$

where β is the pulse compression ratio.

C.5.4.7 Azimuth Accuracy

C.5.4.7.1 Sliding Window

The process of combining the detected data and estimating the angular position of a target, to improve the sensitivity and accuracy, is in many ways equivalent to the matched filtering process which is applied in the range (time) domain. The chief difference is that the process being described here involved incoherent integration. Coherent integration is more effective at improving the signal-to-noise ratio, but if it applied across the whole of the effective beamwidth of the radar, then the ability to resolve angular position to better than this is lost. If a number of pulses are integrated incoherently, however, both the signal-to-noise ratio and the angular accuracy can be improved simultaneously.

The same process can be applied to a coherent radar if, as is typically done, a number of coherent bursts are transmitted over the beam width and the signal is rectified after processing each burst. The process is less efficient if a firm detection is made on each burst, to allow the range or Doppler ambiguities to be resolved by using different Pulse Repetition Frequencies, but a similar process is still possible.

The optimum filter is a matched filter, i.e., a finite impulse response filter with a tapped delay and weights corresponding to the shape of the two-way antenna pattern. This would give the optimum response,

but because the processing must be carried out separately on each range cell a simpler process is often used, such as a recursive (infinite impulse response) filter, of which a first-order lag (low pass filter) is the simplest example.

Figure C-7 shows the typical effect of such a filter. ‘WBI’ stands for ‘Within-Beam Integrator’, this being a conventional name for such a filter.

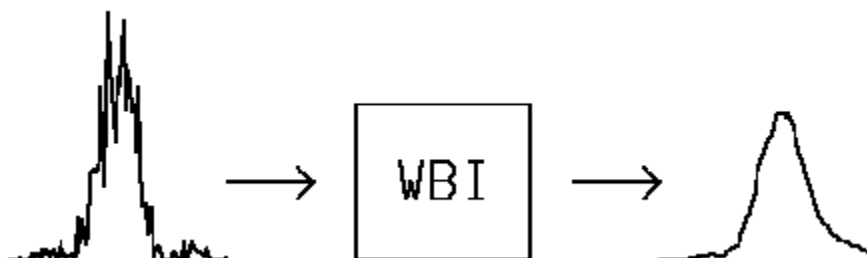

Figure C-7: Effect of the Within Beam Integrator.

The input sequence is a series of noisy, fluctuating, returns seen in the given range cell over a number of pulses, and the output is a smoothed version of the same. Besides improving the ability to detect, it can be seen that the bearing of the target can now be estimated much more accurately than before, based either on the position of the peak, or on some other scheme.

The curve in Figure C-8 shows the maximum attainable angular accuracy for plot extraction for such a track-while-scan system.

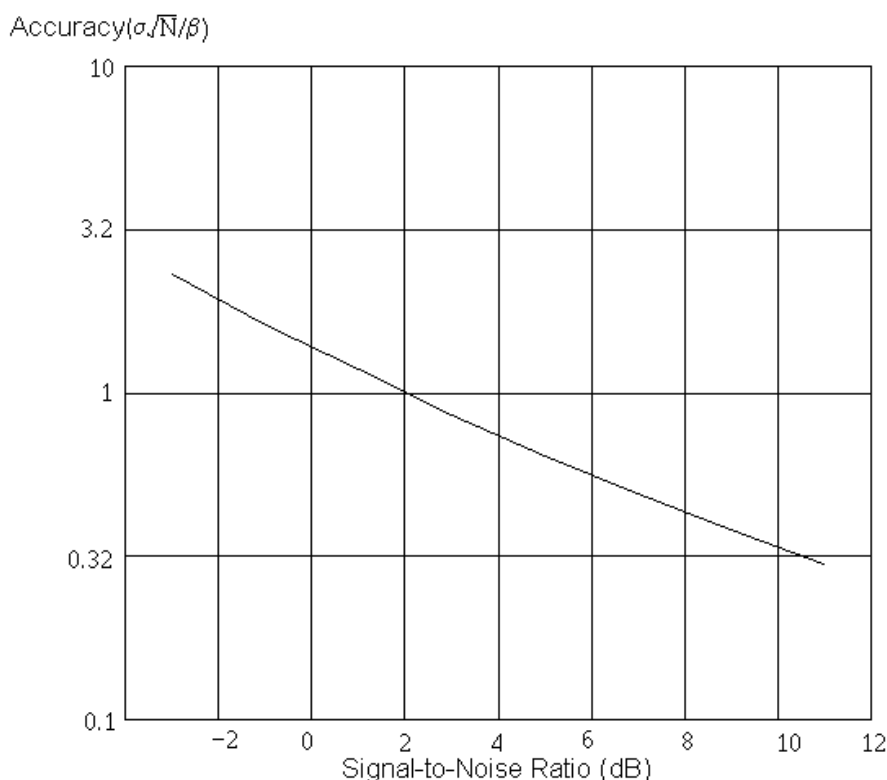

Figure C-8: Theoretical Angular Accuracy vs. Signal-to-Noise Ratio.

The units are the ratio of the product of the standard deviation of the position, normalised by being multiplied by the square root of the number of pulses, to half the one-way 3 dB beamwidth. The curve represents the Cramér-Rao lower bound, i.e., it is derived from information-theoretic considerations of the signal-to-noise ratio in the data. The curve is copied from Ref. [1], but the data has been scaled to match the different notation employed by other users, as described above.

It can be seen that the results follow the approximate law that the accuracy is proportional to the square root of the signal-to-noise ratio after integration (i.e., is approximately proportional to the square root of the single-pulse signal-to-noise ratio multiplied by the square root of the number of pulses), which is the same law found for coherent systems such as monopulse angular estimation or high accuracy range estimates. Therefore interference that degrades the overall signal-to-noise ratio will degrade the angular accuracy.

C.5.4.7.2 *Monopulse Extraction*

The effect of interference on a monopulse extractor is somewhat different in a monopulse extractor bearing measurements are made on each individual pulse.

Replies from the target are received simultaneously on two receiver channels: one received on the Sum or Σ channel and one on the Difference or Δ channel. The voltage ratio of the two signals received is compared to a calibration table derived from the ratio of the $\Delta\Sigma$ antenna pattern voltage gains as a function of angle off-boresight. Thus the measured voltage ratio can be turned directly into an off-boresight angle.

Because the system measures the bearing on each pulse the P_D does not to a first-order effect the bearing measurement as it does in the sliding window extractor. It does have a second-order effect on some systems where the monopulse replies are averaged to get a more accurate result. The lack of some replies will reduce the accuracy improvement due to averaging.

If we first consider the effect of noise on the bearing measurement, the noise in each channel has a random relationship with the noise in that channel. The detected video amplitude is affected by the noise if the noise is in phase or in anti-phase with the signal for signal-to-noise ratios of greater than approximately 2:1 the quadrature phase noise has only a small effect on the measured amplitude and is generally neglected. This restriction of the noise effectively reduces the noise level by 3 dB.

A further consideration is that when the noise in both channels are in phase the effect of the noise tends to cancel depending on the relative S/N ratios. For simplicity however this factor is normally ignored and the noise voltage δ_{nV} is generally said to result in the following worst case condition of the $\Delta\Sigma$ ratio:

$$\frac{\Delta + \delta_{nV}}{\Sigma - \delta_{nV}} \quad (\text{C-10})$$

If we now consider the effect of noise-like interference, in this case because the interference signal is derived from a common source then the interfering voltages $\delta_{IV\Delta}$ and $\delta_{IV\Sigma}$ are in phase. This results in the following:

$$\frac{\Delta + \delta_{nV} + \delta_{IV\Delta}}{\Sigma - \delta_{nV} + \delta_{IV\Sigma}} \quad (\text{C-11})$$

If we define the interfering signal relative to the Δ channel and the noise voltage is $\delta_{IV\Delta} = \delta_{nV}$ which is the voltage resulting from an interfering signal 6 dB below the noise, the noise in the Σ and Δ channels are the same. The $\Delta\Sigma$ ratio is modified to be:

$$\frac{\Delta + \delta_{nV} + \delta_{IV}}{\Sigma - \delta_{nV} + \left(\frac{A}{a}\right) \delta_{IV}} \quad (C-12)$$

If we define the interfering signal relative to the Σ channel then the Δ/Σ ratio becomes:

$$\frac{\Delta + \delta_{nV} + \left(\frac{a}{A}\right)^{0.5} \delta_{IV}}{\Sigma - \delta_{nV} + \delta_{IV}} \quad (C-13)$$

where A is the effective area of the Σ channel antenna and a is the effective area of the Δ antenna.

In this case because $A \gg a$ then the equation can be simplified to:

$$\frac{\Delta + \delta_{nV}}{\Sigma - \delta_{nV} + \delta_{IV}} \quad (C-14)$$

Because of the uncorrelated nature of the receiver noise and the fact that the error is related to the noise voltage then an interfering signal of power 6 dB below the noise could result in an effect on the bearing error equal to the effect of the noise alone.

M.I. Skolnik: *Radar Handbook* (2nd Edition), 1990, quotes the monopulse error as function of S/N as:

$$\Delta\theta_m = \frac{\Theta_B}{K_m \sqrt{B \tau \left(S/N \frac{f_r}{\beta_n} \right)}} \quad (C-15)$$

where: $\Delta\theta_m$ = Monopulse error

Θ_B = Beamwidth (-3dB)

K_m = Monopulse slope factor

B = Receiver bandwidth

τ = Pulse width

S/N = Signal-to-noise ratio

f_r = PRF

β_n = Servo bandwidth

The monopulse error as a fraction of beamwidth is given by:

$$\frac{\Delta\theta_m}{\Theta_B} = \frac{1}{K_m \sqrt{B \tau \left(S/N \frac{f_r}{\beta_n} \right)}} \quad (C-16)$$

where: K_m : 1.2 to 1.9 value depends on design of antenna, 1.6 typical

$B\tau$: 1 (matched receiver)

β_n : 1, 10, 100, 1000

This is shown graphically in Figure C-9.

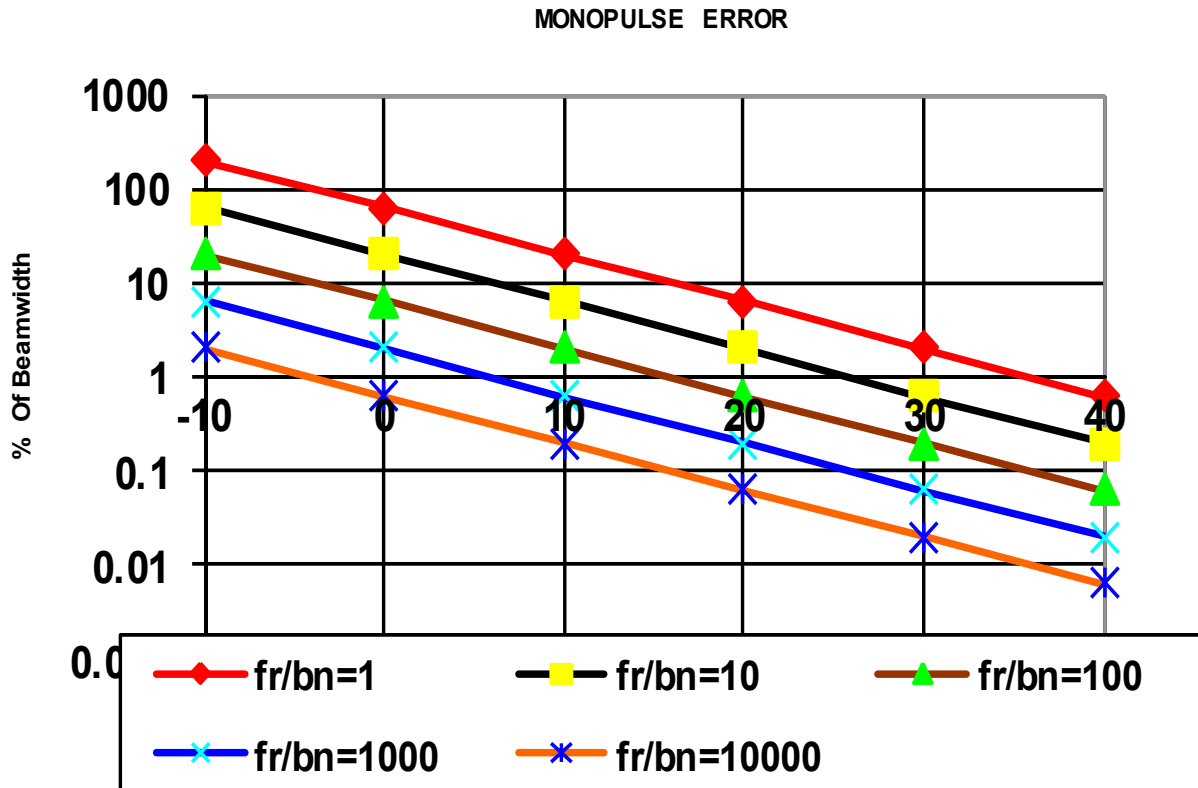

Figure C-9: Monopulse Error as a Fraction of Beamwidth.

C.5.4.8 Effects on Other Parameters

It can be shown that both velocity and acceleration accuracy are affected by the S/N .

C.5.4.8.1 Velocity Measurements

Error in Velocity measurement δ_v is:

$$\delta_v = \frac{\lambda}{4 \times \tau \times \sqrt{S/N}} \tag{C-17}$$

where τ is the pulse length, compressed, if appropriate.

C.5.4.8.2 Acceleration

The error in acceleration δ_A is:

$$\delta_A = \frac{\lambda}{2 \times T^2 \times \sqrt{2S/N}} \quad (\text{C-18})$$

where T is the burst length.

Note that the accuracy of all these measurements is approximately proportional to the square root of the signal-to-noise ratio.

C.5.4.9 Permanent Effects

In the limit the interference can be so severe as to permanently damage the radar receiver. This damage can be partial, i.e., a permanent desensitisation or complete, i.e., loss of all detection capability. These effects are irresistible and permanent.

C.5.5 Some Interference Scenarios

Interference can manifest itself in several ways, and once it has entered the radar system it is particularly difficult to eradicate completely, some residue will always be present.

The following section analyses several interference scenarios, where each scenario includes a discussion as to the overall effect of the interference on the radar system's ability to continue satisfactory operation.

Scenarios 1 and 2 illustrate interference effects in the Frequency domain, whereas the rest concentrate on illustrating the effects in the Time domain.

C.5.5.1 Scenario 1 – Interference Signals in the Frequency Domain

C.5.5.1.1 Broad-Band Interference Signal Scenarios

Broad-band interference can be thought of as interference that has a significant level of constant energy over a wide range of frequencies. From the point of view of the radar receiver, broad-band interference covers the entire frequency range of the passband. In most cases, the interference signal actually covers a wider band than that specified by the passband of the receiver. Hence, the term 'Broad-band'.

This particular scenario presents two cases of broad-band interference generation:

- Broad-band noise-like interference; and
- Broad-band non-noise-like interference.

C.5.5.1.2 Broad-Band Noise-Like Interference

Figure C-10 shows a broad-band interference signal present in the passband of a radar receiver. Purely through its nature it has the effect of increasing the radar receiver noise floor by the appropriate amount. If the radar system operates a CFAR system, the increase in noise floor will be matched by an increase in the minimum detectable signal threshold, effectively reducing the maximum detectable range.

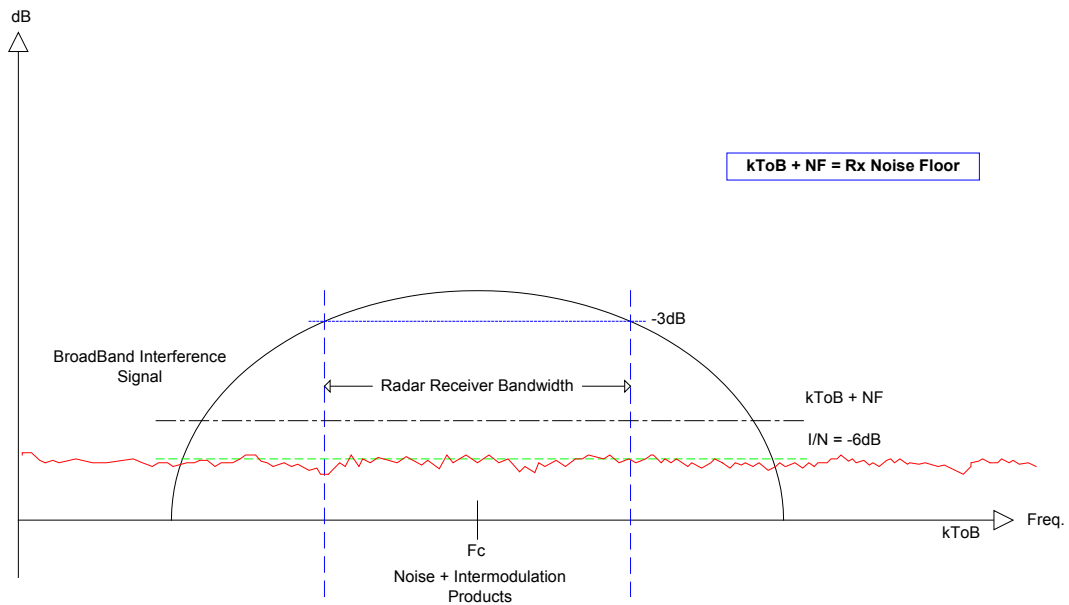

Figure C-10: Broad-Band Noise-Like Interference Signal Present in Receiver Bandwidth.

The view of broad-band interference shown in Figure C-10 is the traditional representation.

C.5.5.1.3 Broad-Band Non-Noise-Like Interference

Figure C-11 shows a large pulsed interference spectrum present within the vicinity of the radar system receiver. The interference has several spurious harmonic lines that enter the receiver bandwidth and mix with other harmonics to form inter-modulation products that fall directly into the radar band of interest. These products and associated harmonics form a constant amplitude interference signal just below the noise floor of the radar receiver.

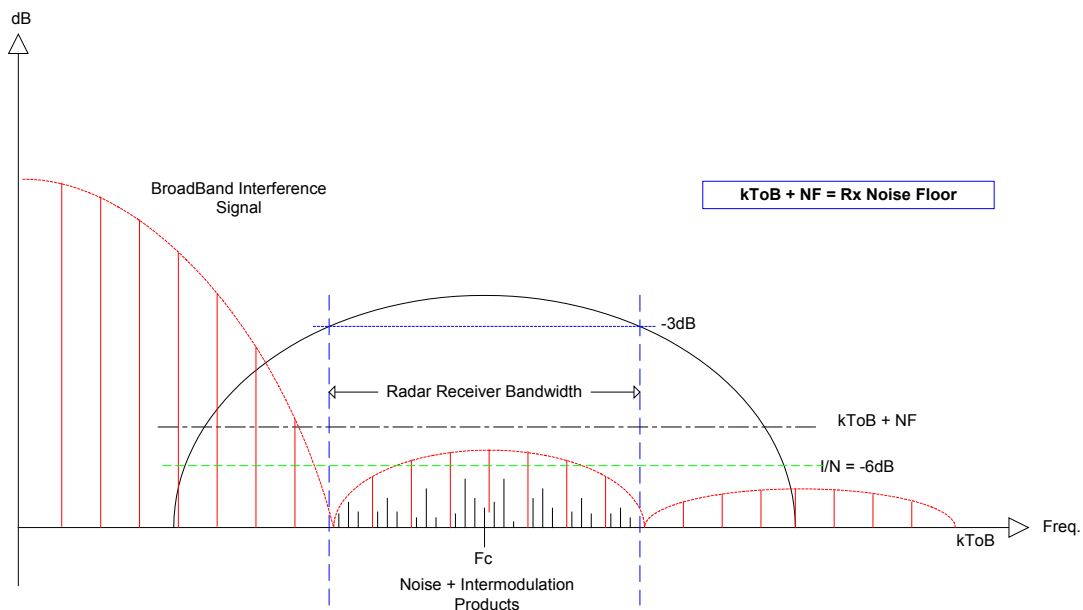

Figure C-11: Broad-Band Non-Noise-Like Interference Signal Present in Receiver Bandwidth.

Even though the receiver bandwidth is clearly defined, it fails to remove the interference from the band of interest.

These interference signals have been included to demonstrate the fact that the interference can be constructed from many harmonics mixing together within the band of interest (as opposed to a continuous rolling floor that is constructed from an infinite number of harmonics). Its effect is identical to the broad-band noise-like interference signal.

In both Figure C-10 and Figure C-11, the interference is shown situated well below the noise floor of the receiver, but it is within the -6 dB specified value of I/N . As mentioned earlier, the effect of this is to cause the noise floor of the radar receiver to rise accordingly. For a radar system operating a CFAR regime the effect can be minimised at the expense of maximum detectable range, but if a radar system is operating a non-CFAR regime, the effect is to increase the false alarm rate to an unacceptable level as the probability of false alarm increases.

Broad-band interference causes a gradual degradation of the receiver, as it becomes marginally desensitised to targets at certain ranges and ultimately degrades the performance of the radar, until its performance is below that which is required.

This scenario has represented interference in two of its most common forms, that of constant spectral power with infinite harmonics, and with several harmonics that produce inter-modulation products when mixed with other signals present. Both methods produce a constant floor that is particularly difficult to remove and can cause significant degradation to the radar system performance, even when situated below the radar receiver noise floor.

C.5.5.1.4 Narrow-Band Interference Signal Scenario

Narrow-band noise is a more selective form of interference. The term ‘narrow-band’ comes from the fact the interference signal is much less than the bandwidth of the victim receiver. In practical terms this is not much of a problem if the signal is situated below the noise floor. However, it becomes more problematic when its energy level takes it above the noise threshold of the victim receiver.

In this scenario, several small amplitude harmonics are generated by an interference source situated in close proximity to the radar receiver bandwidth. (Alternatively, the narrow-band signal could have been generated by a large signal quite some distance away that has high-energy harmonic orders). In this case, a small group of harmonics is placed directly in the passband of the radar receiver. This is shown in Figure C-12. The power integral of the spikes over the passband determines the level of interference.

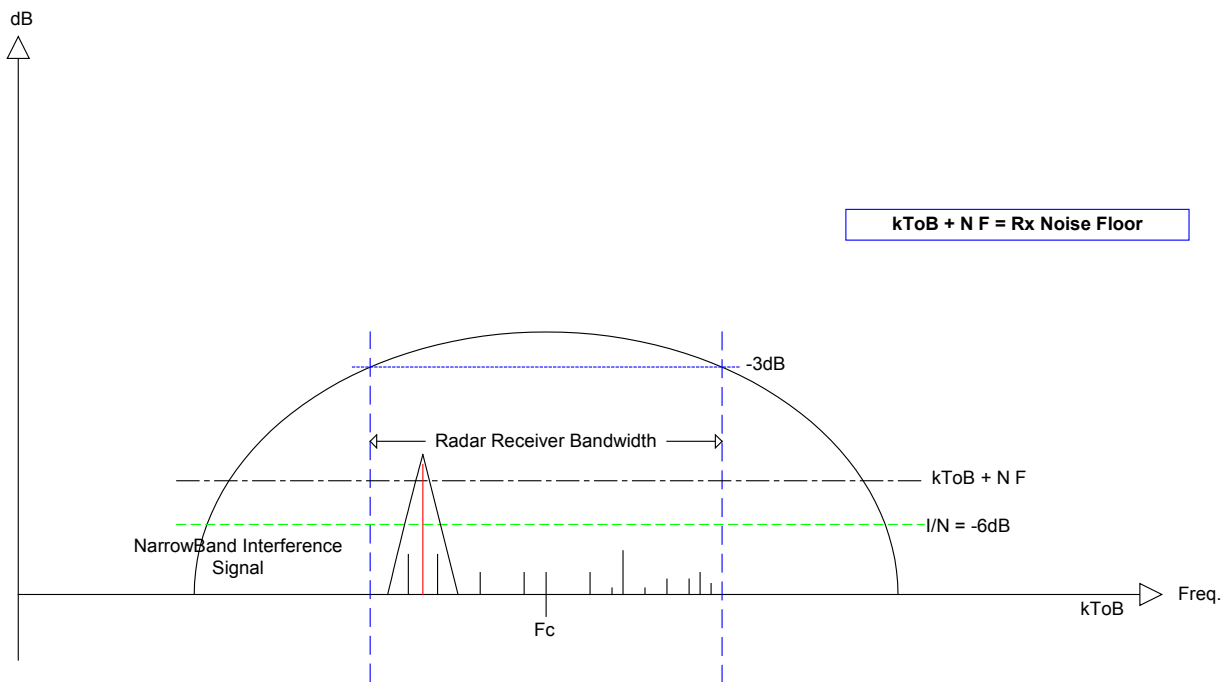

Figure C-12: Narrow-Band Interference Signal Present in Receiver Bandwidth.

Although off-tune, the collection of harmonics produces a narrow-band interference signal.

Assuming that the double down-conversion process does not remove the narrow-band interference signal and that the power contained within the interference signal is large, it is possible that a very small increase in noise floor could be noticed. However, the effect of this increase will not be as severe as the effect delivered by its broad-band counterpart.

It may be noted that since a CW signal does not increase the variance of the signals, an ideal CFAR system will recognise this and the CW signal will not desensitise the receiver, although in practice few, if any, CFAR systems are this good.

Now assume that the narrow-band interference source is situated within the receiver bandwidth. If its spectral response were that partially resembling a pulsed return, if it is synchronous with the radar Pulse Repetition Interval (PRI) and pulse duration and has sufficient energy, the possibility of false target generation is increased.

It must also be considered that narrow-band noise can have long time duration, to the extent that if it tended towards Continuous Wave (CW), it would then infect the receiver on a continuous basis.

C.5.5.2 Scenario 2 – Interference in the Time Domain

The following set of scenarios assumes that the interference signal has adopted the approximate spectral form of a pulsed target return, has adequate spectral energy and is situated in the receiver bandwidth.

C.5.5.2.1 Aperiodic, Pulsed Interference Signal Applied to a Non-Compressed Radar System

Assume that the victim radar system utilises a non-compressed, pulsed CW waveform. Figure C-13 illustrates a pulsed interference signal that occurs within the system PRI, but is aperiodic on a pulse-to-pulse basis.

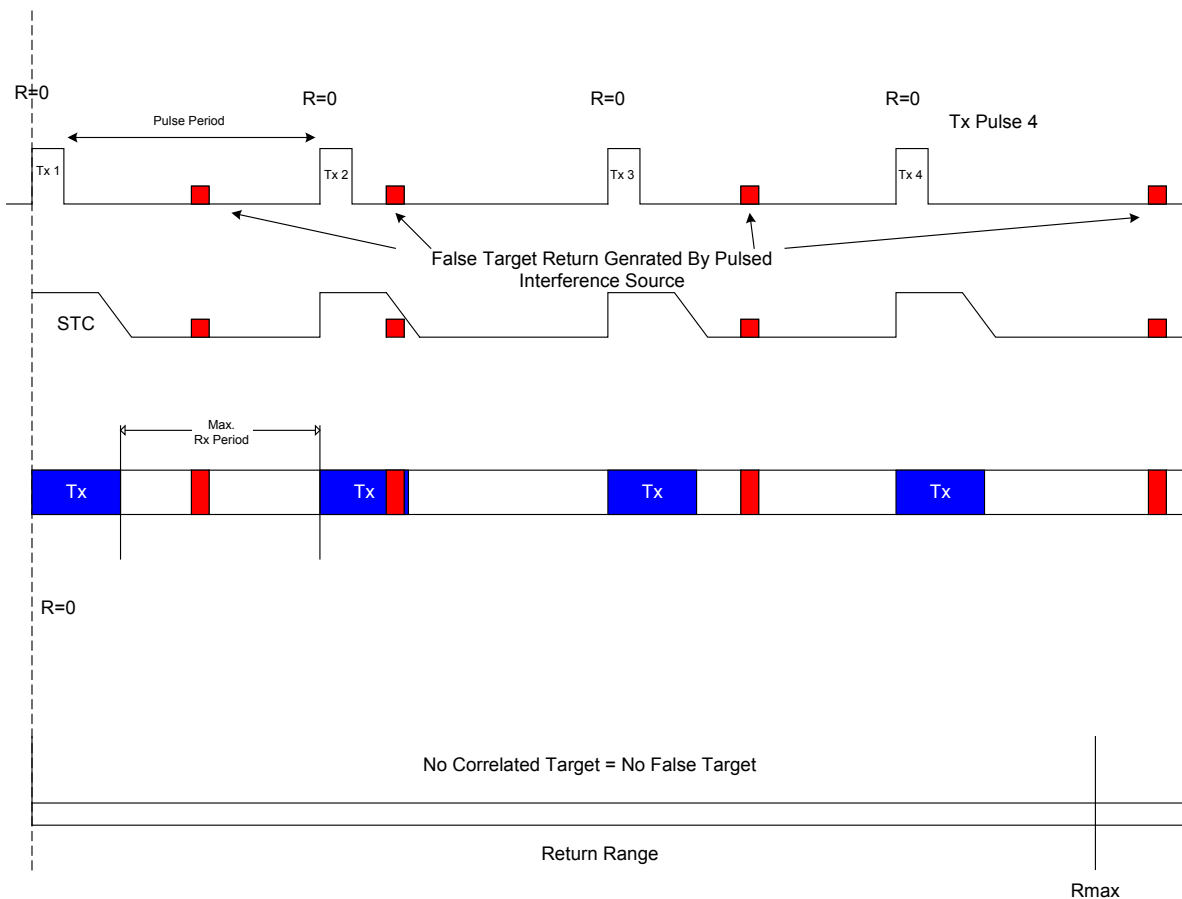

Figure C-13: Aperiodic, Pulsed Interference Signal Applied to a Non-Compressed Radar System.

Figure C-13 illustrates a possible interference scenario where a false target return could be generated by a pulsed interference signal. It shows four transmit periods for one particular sector in azimuth, in each period the interference occurs at a different range – appearing random in nature.

For a victim radar system that employs pulse correlation, the randomness of the interference will result in rejection as it does not correlate on a periodic basis. Genuine target returns correlate. Also in this scenario, pulsed interference signal 2 appears in the STC region, so this signal will be ignored.

If the victim radar system were basic enough not to employ some form of pulse correlation, then for each transmitted pulse, a corresponding target return would be detected. This could lead to many false targets being generated.

The victim radar system illustrated in this scenario relies on the principle that the pulsed interference is asynchronous with the radar’s pulse pattern. This allows the use of a pulse correlation system to make a decision on signal acceptance or rejection. The success of a pulse correlation system, when supplied with data from an interference source, does hinge on the periodicity of the pulsed interference signal.

C.5.5.2.2 Periodic, Pulsed Interference Signal Applied to a Non-Compressed Radar System

This scenario now assumes that the pulsed interference signal is periodic in its nature and is synchronous with the victim radar system PRI. This scenario shows that a false target will be generated and is shown in Figure C-14.

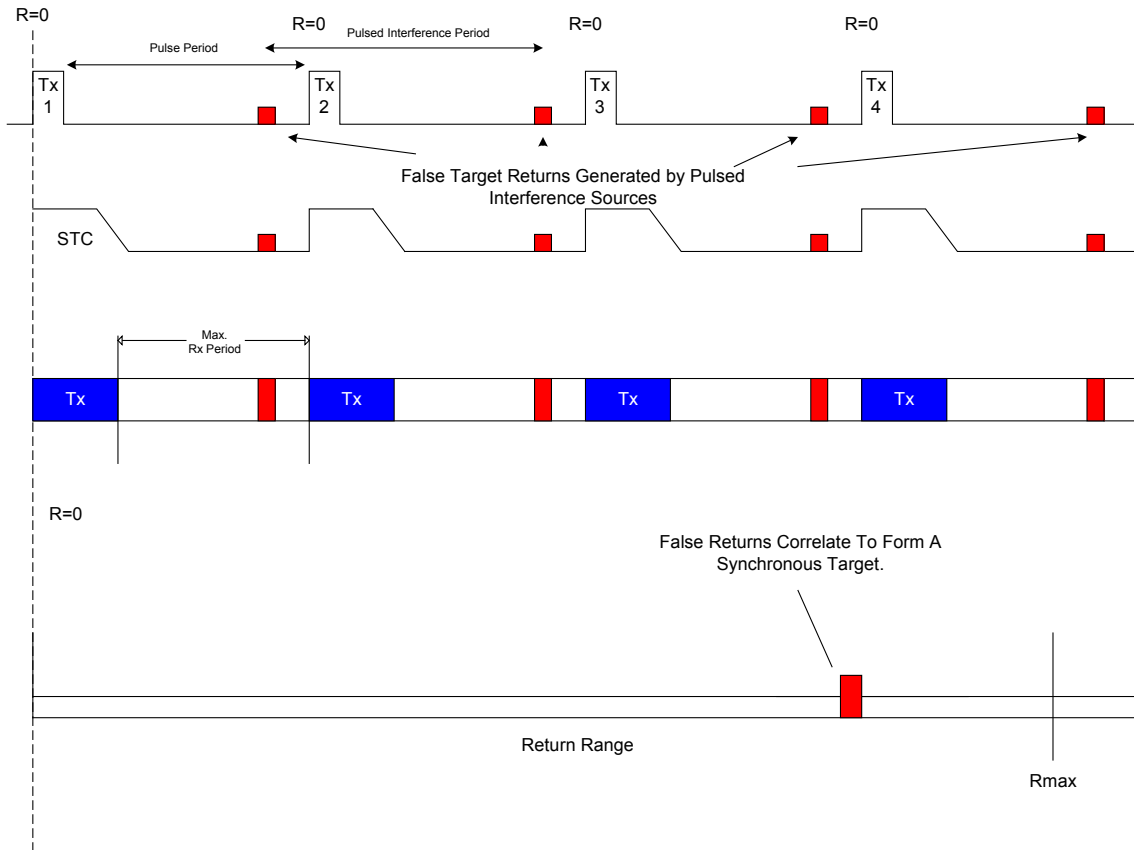

Figure C-14: Periodic, Pulsed Interference Signal Applied to a Non-Compressed Radar System.

The simplistic Figure C-14 shows a false target return generated by a pulsed interference signal at the same point for all four receive periods. These are passed to the detection/correlation system and deemed to correlate. The returns are coherent to the PRI of the system.

In this particular scenario the probability of false target detection is drastically increased due to being synchronous with the radar PRI. These returns will correlate, as they occur within the same range for each successive PRI.

C.5.5.2.3 Periodic, Multiple Pulsed Interference Signals Applied to a Non-Compressed Radar System

This scenario now assumes that many false target returns are generated by many pulsed interference signals. This leads to a varying set of situations.

In the frequency domain, if enough pulsed returns are present over a span of time, then the interference would act as near broad-band noise. This would result in the scenario as per broad-band noise and would cause false alarms, as the characteristic noise would not follow the Rayleigh distribution and prevent the correct operation of CFAR systems.

If the returns were randomly distributed in time, with no discernible periodic component, a pulse correlation system could remove the unwanted returns, as they would not correlate on a pulse-to-pulse basis.

However, the situation shown in Figure C-15 is the most likely occurrence.

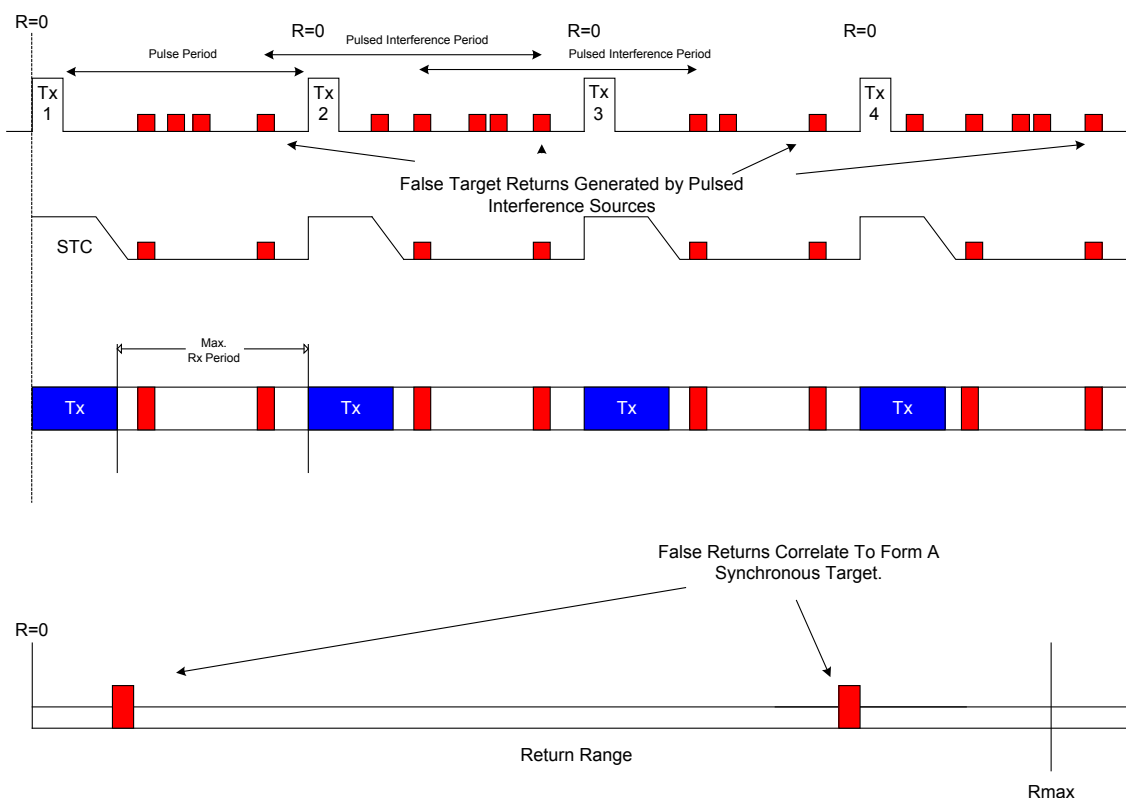

Figure C-15: Periodic, Multiple Pulsed Interference Signals Applied to a Non-Compressed Radar System.

This shows multiple pulsed interference signals (many are aperiodic in nature), but when passed through a correlator that operates on a periodic principle, it is clear to see that many aperiodic returns have the potential to become ‘periodic’ to the radar system. This is purely on the basis that they occur at the same range for many pulse periods. The figure shows that two periodic components have been identified, and when passed through the pulse correlator, will be correlated to show two false target returns. Both are at a different range, but are on the same azimuth.

In practice it is possible for many more false targets to be generated, and once again it all depends on the correlation of returns between pulse periods. This phenomenon will cause the radar display to become heavily cluttered with false returns.

C.5.5.2.4 Periodic, Pulsed Interference Signal Applied to a Compressed Radar System

This scenario assumes that the radar system uses pulse compression. As has already been discussed, false returns that are aperiodic in time are effectively rejected through correlation, but if the false returns are periodic, there is a possibility that a false target will be generated.

However, now the attention is directed to the reception of interference signals into pulse compression systems. Figure C-16 illustrates a periodic pulsed interference signal that is coherent to the radar system PRI.

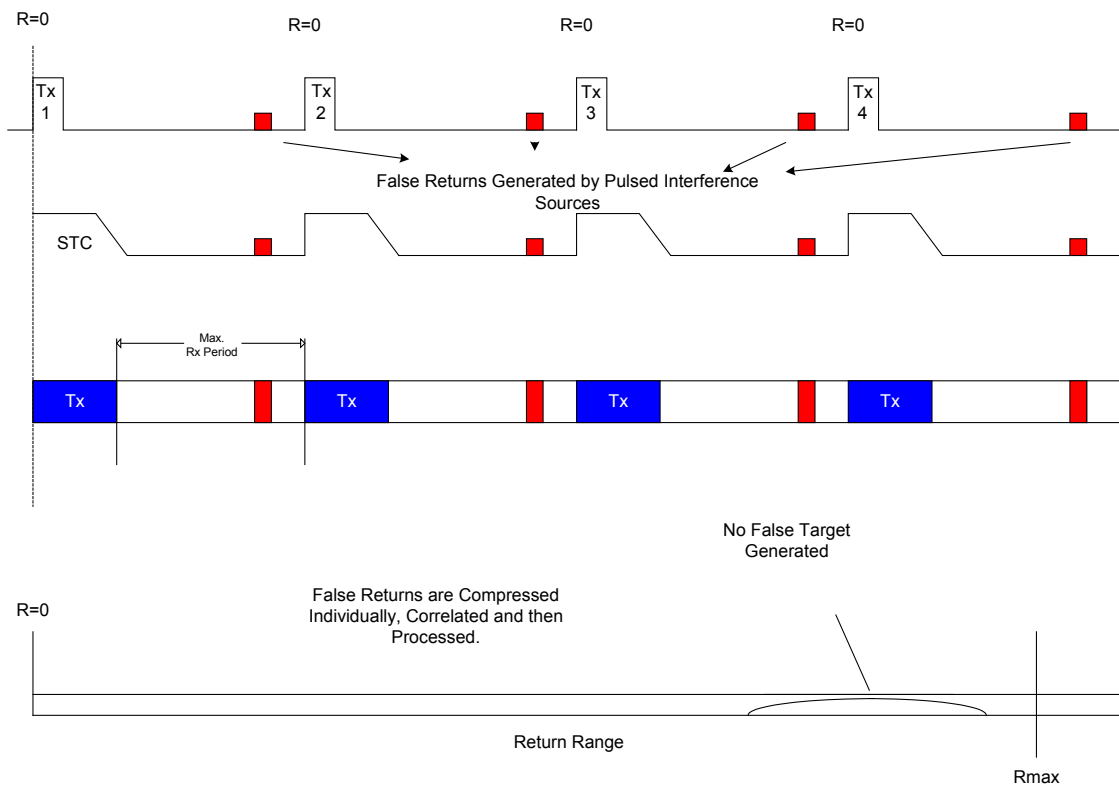

Figure C-16: Periodic, Pulsed Interference Signal Applied to a Compressed Radar System.

The false returns are passed through a pulse compressor system, correlated and processed. However, since the pulsed interference is not matched to the compression of the radar system, the application of the compression system causes the returns to flatten out, as none of the available processing gain is being applied.

Ideally, the compression system should attenuate and reject any signal that is not within its specified parameters. In practice, however, it is quite possible for the radar compression system to allow a pulsed interference signal to pass through, whilst only applying a certain amount of processing gain as stated previously.

Even if a pulsed CW signal is applied to a compression system, some of the processing gain is applied. If the pulsed interference signal is periodic in nature, then it is entirely possible for a false target to be generated, but generally the CFAR circuit will reduce this interference.

In addition, because the interferer is not matched to the pulse compressor, then it is not compressed in time as much as the radar signal. This means that the time sidelobes of such an interferer would be large and span many range gates in the signal processor.

C.5.5.2.5 Periodic, Multiple Pulsed Interference Signals Applied to a Compressed Radar System

The Periodic, Multiple Pulsed Interference scenario discussed above applies equally to this scenario.

C.5.5.2.6 Periodic, Compressed Pulsed Interference Signal Applied to a Compressed Radar System

This scenario is possibly the most problematic of all pulsed scenarios discussed. Suppose that a pulsed interference signal is frequency swept, or digitally encoded to match its own compression system. It is

possible that the compression encoding used in the radar system could be close to the interference signal compression encoding. This would result in the false returns passing through the radar system compressor, being partially compressed, and generating a false target return. This scenario would occur between two radars of the same model.

In this scenario only a portion of the processing gain need be applied, since pulse compressors are rarely perfect. This would result in partial gain being applied to a false return. Once the periodic correlation has been processed, a false target return could be generated.

In the commentary, it is illustrated that a pulsed CW waveform can have processing gain applied.

In conclusion, it may be noted that CW-type interference is best handled by CFAR-type processing whereas impulse interference is best handled by pulse-to-pulse correlation.

C.6 CONCLUSIONS

C.6.1 General

There are potential problems associated with frequency sharing between radar and mobile telecoms:

- Sharing spectrum with licensed services.
- Impact of proliferation of unlicensed services (e.g., UWB).
- Radar is particularly susceptible due to the large receiver apertures and high receiver sensitivity.
- Noise-like interference is likely to cause the worst problems for radar.

Frequency sharing is easier if planned at the outset, e.g., mobile telephones.

Radar ECCM techniques help reduce the impact of interference.

There is evidence to suggest that DFS (Dynamic Frequency Selection) does not work as well as early modelling predicted:

- Technology watch required.
- Careful evaluation required of any scheme that relies on this technique.
- Practical evaluation is essential to fully understand the impact of comms on radar (do not rely on modelling alone).

C.6.2 Antennas

In order to constrain the reception to the wanted directions the following mitigation options can be pursued.

- The design of reflector antennas could be improved, and in the limit, cylindrical reflector antennas could be used.
- Array antennas could use a larger aperture.
- Elevation patterns should be designed to minimise surface and structural reflections. This may require the use of stabilised mounts on naval systems.
- Larger antennas may require the use of radomes; preferably these should be sandwich design with matched joints. Water shedding surfaces must be used.
- All obstructions should be removed from illumination by the main beam.

C.6.3 Receivers

The following are good design practice:

- Good frequency selectivity (i.e., superhet receiver).
- High dynamic range.
- CFAR suppresses continuous interference.
- Pulse to pulse correlation suppresses impulsive interference.
- Pulse compression reduces the impact of uncorrelated noise.

C.6.4 Impact on Military Radars

The principal conclusion from this section of the report is that for a well-designed military radar:

- The most appropriate measure of the military impact of interference is in fact the interference-to-noise ratio. This is because treating the interference as noise is a safe worst-case for estimating its effect on a well-designed military radar.
- The effect of interference on the technical behaviour of the complete radar will be very similar to its effect on the simple case of detection of a non-fluctuating target. In fact, the radar design will tend to overcome the effects possibly introduced by other complications in the scenario.
- The military impact of the interference can be equated to the increase in the effective noise power due to the interference, since this is closely related to the cost of restoring the performance to what it would have been in the absence of the interference.
- If particular details are available of the interference, the radar and the scenario, then a more detailed analysis may be undertaken, but in most cases it will be found that the difference between this and predictions of the simpler approach will not be significant.
- Radars should not be considered to have any spare capacity since any apparently-spare capacity can be put to good use to provide robustness against changing threat scenarios and military requirements.
- Changes in sensitivity of 1 dB can readily be detected over the long run, and, similarly, can have a significant effect on the effectiveness of the system when it is pushed to its limit of performance by the demands of military operations.

C.6.5 Impact of UWB

This document presents the state-of-the-art concerning frequency sharing between UWB communication equipment and military radar:

- Today, FCC and ECC have defined emission masks for UWB transmitter. These masks were designed to minimise interference risk to other radio communication equipment. FCC has proposed two emission masks: one for indoor application; and one for outdoor. ECC has only considered UWB for indoor communication. Today, we do not know if ITU will harmonise the emission mask for the 3 Regions or not.
- The main interference risks between military radar and UWB devices concern ground-based radar in an urban environment or near a “hot spot”. The risks will increase if outdoor UWB transmitter concept is developed. The consequences of interference are de-sensitisation of the receiver (deployment of a lot of UWB devices) and false alarm (few UWB transmitters very close to the radar). In an urban scenario and with the assumptions of the ECC emission mask, a ground-based radar could not be affected by indoor UWB interference when this devices are situated up to 500 m from the radar. Nevertheless, the proliferation of UWB transmitter will never be controlled.

- Because of the diversity of radars and waveforms for UWB devices, experimentation will be necessary to define exactly the performance degradation of the radar receiver from UWB transmitters.
- The potential problem of incompatibility between military radar and UWB devices could occur when radar and UWB devices have to be integrated in the same weapon system. Care must be taken into account in specifications and realisation of military systems.
- Until now, the conclusion of compatibility between radar and UWB devices are based on simulations and calculations which do not modelled exactly the radar receiver. When UWB devices will be available, experimentation will be necessary to assess how radar performances will be degraded by UWB signals.
- UWB devices can generate interference to radar principally in urban environment and in “hot spot” configuration. The principal interrogation with UWB devices concerned the uncontrolled proliferation and outdoor communication applications.
- It will be important to follow ITU decisions about harmonisation of UWB emission mask in future months.

C.6.6 Transmitter

Filtering the transmit signal can lessen out-of-band signals.

C.7 REFERENCE

- [1] Swerling, P. “Probability of Detection for a Fluctuating Target”, Rand Research Memorandum RM-1217, March 1954, reproduced in *IEEE Trans. Information Theory*, 6, pp. 269-308, April 1960.

REPORT DOCUMENTATION PAGE											
1. Recipient's Reference	2. Originator's References	3. Further Reference	4. Security Classification of Document								
	STO-TR-SET-182 AC/323(SET-182)TP/695	ISBN 978-92-837-2095-9	PUBLIC RELEASE								
5. Originator	Science and Technology Organization North Atlantic Treaty Organization BP 25, F-92201 Neuilly-sur-Seine Cedex, France										
6. Title	Radar Spectrum Engineering and Management										
7. Presented at/Sponsored by	Final Report of Task Group SET-182.										
8. Author(s)/Editor(s)	Multiple		9. Date April 2016								
10. Author's/Editor's Address	Multiple		11. Pages 152								
12. Distribution Statement	There are no restrictions on the distribution of this document. Information about the availability of this and other STO unclassified publications is given on the back cover.										
13. Keywords/Descriptors	<table style="width: 100%; border: none;"> <tr> <td style="width: 50%;">Interference</td> <td style="width: 50%;">Radar waveforms</td> </tr> <tr> <td>Passive radar</td> <td>RF spectrum</td> </tr> <tr> <td>Radar</td> <td>Spectrum regulation</td> </tr> <tr> <td>Radar transmitters</td> <td></td> </tr> </table>			Interference	Radar waveforms	Passive radar	RF spectrum	Radar	Spectrum regulation	Radar transmitters	
Interference	Radar waveforms										
Passive radar	RF spectrum										
Radar	Spectrum regulation										
Radar transmitters											
14. Abstract	<p>The Radio-Frequency (RF) electromagnetic spectrum, extending from below 1 MHz to above 100 GHz, represents a precious resource. It is used for a wide range of purposes, including communications, radio and television broadcasting, radio navigation, and sensing. Radar represents a fundamentally important use of the Electromagnetic (EM) spectrum, in applications which include air traffic control, geophysical monitoring of Earth resources from space, automotive safety, severe weather tracking, and surveillance for defence and security. Nearly all services have a need for greater bandwidth, which means that there will be ever-greater competition for this finite resource. The report explains the nature of the spectrum congestion problem from a radar perspective, and describes a number of possible approaches to its solution both from technical and regulatory points of view. These include improved transmitter spectral purity, passive radar, and intelligent, cognitive approaches that dynamically optimize spectrum use.</p>										





BP 25
F-92201 NEUILLY-SUR-SEINE CEDEX • FRANCE
Télécopie 0(1)55.61.22.99 • E-mail mailbox@cs0.nato.int



DIFFUSION DES PUBLICATIONS
STO NON CLASSIFIEES

Les publications de l'AGARD, de la RTO et de la STO peuvent parfois être obtenues auprès des centres nationaux de distribution indiqués ci-dessous. Si vous souhaitez recevoir toutes les publications de la STO, ou simplement celles qui concernent certains Panels, vous pouvez demander d'être inclus soit à titre personnel, soit au nom de votre organisation, sur la liste d'envoi.

Les publications de la STO, de la RTO et de l'AGARD sont également en vente auprès des agences de vente indiquées ci-dessous.

Les demandes de documents STO, RTO ou AGARD doivent comporter la dénomination « STO », « RTO » ou « AGARD » selon le cas, suivi du numéro de série. Des informations analogues, telles que le titre et la date de publication sont souhaitables.

Si vous souhaitez recevoir une notification électronique de la disponibilité des rapports de la STO au fur et à mesure de leur publication, vous pouvez consulter notre site Web (<http://www.sto.nato.int/>) et vous abonner à ce service.

CENTRES DE DIFFUSION NATIONAUX

ALLEMAGNE

Streitkräfteamt / Abteilung III
Fachinformationszentrum der Bundeswehr (FIZBw)
Gorch-Fock-Straße 7, D-53229 Bonn

BELGIQUE

Royal High Institute for Defence – KHID/IRSD/RHID
Management of Scientific & Technological Research
for Defence, National STO Coordinator
Royal Military Academy – Campus Renaissance
Renaissancelaan 30, 1000 Bruxelles

BULGARIE

Ministry of Defence
Defence Institute "Prof. Tsvetan Lazarov"
"Tsvetan Lazarov" bul no.2
1592 Sofia

CANADA

DGSIST
Recherche et développement pour la défense Canada
101 Colonel By Drive, 6 CBS
Ottawa, Ontario K1A 0K2

DANEMARK

Danish Acquisition and Logistics Organization
(DALO)
Lautrupbjerg 1-5
2750 Ballerup

ESPAGNE

Área de Cooperación Internacional en I+D
SDGPLATIN (DGAM)
C/ Arturo Soria 289
28033 Madrid

ESTONIE

Estonian National Defence College
Centre for Applied Research
Riia str 12
Tartu 51013

ETATS-UNIS

Defense Technical Information Center
8725 John J. Kingman Road
Fort Belvoir, VA 22060-6218

FRANCE

O.N.E.R.A. (ISP)
29, Avenue de la Division Leclerc
BP 72
92322 Châtillon Cedex

GRECE (Correspondant)

Defence Industry & Research General
Directorate, Research Directorate
Fakinos Base Camp, S.T.G. 1020
Holargos, Athens

HONGRIE

Hungarian Ministry of Defence
Development and Logistics Agency
P.O.B. 25
H-1885 Budapest

ITALIE

Centro Gestione Conoscenza
Secretariat General of Defence
National Armaments Directorate
Via XX Settembre 123/A
00187 Roma

LUXEMBOURG

Voir Belgique

NORVEGE

Norwegian Defence Research
Establishment
Attn: Biblioteket
P.O. Box 25
NO-2007 Kjeller

PAYS-BAS

Royal Netherlands Military
Academy Library
P.O. Box 90.002
4800 PA Breda

POLOGNE

Centralna Biblioteka Wojskowa
ul. Ostrobramska 109
04-041 Warszawa

PORTUGAL

Estado Maior da Força Aérea
SDFA – Centro de Documentação
Alfragide
P-2720 Amadora

REPUBLIQUE TCHEQUE

Vojenský technický ústav s.p.
CZ Distribution Information Centre
Mladoboleslavská 944
PO Box 18
197 06 Praha 9

ROUMANIE

Romanian National Distribution
Centre
Armaments Department
9-11, Drumul Taberei Street
Sector 6
061353 Bucharest

ROYAUME-UNI

Dstl Records Centre
Rm G02, ISAT F, Building 5
Dstl Porton Down
Salisbury SP4 0JQ

SLOVAQUIE

Akadémia ozbrojených síl gen.
M.R. Štefánika, Distribučné a
informačné stredisko STO
Demänová 393
031 06 Liptovský Mikuláš 6

SLOVENIE

Ministry of Defence
Central Registry for EU & NATO
Vojkova 55
1000 Ljubljana

TURQUIE

Milli Savunma Bakanlığı (MSB)
ARGE ve Teknoloji Dairesi
Başkanlığı
06650 Bakanlıklar – Ankara

AGENCES DE VENTE

**The British Library Document
Supply Centre**
Boston Spa, Wetherby
West Yorkshire LS23 7BQ
ROYAUME-UNI

**Canada Institute for Scientific and
Technical Information (CISTI)**
National Research Council Acquisitions
Montreal Road, Building M-55
Ottawa, Ontario K1A 0S2
CANADA

Les demandes de documents STO, RTO ou AGARD doivent comporter la dénomination « STO », « RTO » ou « AGARD » selon le cas, suivie du numéro de série (par exemple AGARD-AG-315). Des informations analogues, telles que le titre et la date de publication sont souhaitables. Des références bibliographiques complètes ainsi que des résumés des publications STO, RTO et AGARD figurent dans le « NTIS Publications Database » (<http://www.ntis.gov>).



BP 25
F-92201 NEUILLY-SUR-SEINE CEDEX • FRANCE
Télécopie 0(1)55.61.22.99 • E-mail mailbox@cs.o.nato.int



**DISTRIBUTION OF UNCLASSIFIED
STO PUBLICATIONS**

AGARD, RTO & STO publications are sometimes available from the National Distribution Centres listed below. If you wish to receive all STO reports, or just those relating to one or more specific STO Panels, they may be willing to include you (or your Organisation) in their distribution.

STO, RTO and AGARD reports may also be purchased from the Sales Agencies listed below.

Requests for STO, RTO or AGARD documents should include the word 'STO', 'RTO' or 'AGARD', as appropriate, followed by the serial number. Collateral information such as title and publication date is desirable.

If you wish to receive electronic notification of STO reports as they are published, please visit our website (<http://www.sto.nato.int/>) from where you can register for this service.

NATIONAL DISTRIBUTION CENTRES

BELGIUM

Royal High Institute for Defence – KHID/IRSD/
RHID
Management of Scientific & Technological
Research for Defence, National STO Coordinator
Royal Military Academy – Campus Renaissance
Renaissancelaan 30
1000 Brussels

BULGARIA

Ministry of Defence
Defence Institute "Prof. Tsvetan Lazarov"
"Tsvetan Lazarov" bul no.2
1592 Sofia

CANADA

DSTKIM
Defence Research and Development Canada
101 Colonel By Drive, 6 CBS
Ottawa, Ontario K1A 0K2

CZECH REPUBLIC

Vojenský technický ústav s.p.
CZ Distribution Information Centre
Mladoboleslavská 944
PO Box 18
197 06 Praha 9

DENMARK

Danish Acquisition and Logistics Organization
(DALO)
Lautrupbjerg 1-5
2750 Ballerup

ESTONIA

Estonian National Defence College
Centre for Applied Research
Riaa str 12
Tartu 51013

FRANCE

O.N.E.R.A. (ISP)
29, Avenue de la Division Leclerc – BP 72
92322 Châtillon Cedex

GERMANY

Streitkräfteamt / Abteilung III
Fachinformationszentrum der
Bundeswehr (FIZBw)
Gorch-Fock-Straße 7
D-53229 Bonn

GREECE (Point of Contact)

Defence Industry & Research General
Directorate, Research Directorate
Fakinos Base Camp, S.T.G. 1020
Holargos, Athens

HUNGARY

Hungarian Ministry of Defence
Development and Logistics Agency
P.O.B. 25
H-1885 Budapest

ITALY

Centro Gestione Conoscenza
Secretariat General of Defence
National Armaments Directorate
Via XX Settembre 123/A
00187 Roma

LUXEMBOURG

See Belgium

NETHERLANDS

Royal Netherlands Military
Academy Library
P.O. Box 90.002
4800 PA Breda

NORWAY

Norwegian Defence Research
Establishment, Attn: Biblioteket
P.O. Box 25
NO-2007 Kjeller

POLAND

Centralna Biblioteka Wojskowa
ul. Ostrobramska 109
04-041 Warszawa

PORTUGAL

Estado Maior da Força Aérea
SDFA – Centro de Documentação
Alfragide
P-2720 Amadora

ROMANIA

Romanian National Distribution Centre
Armaments Department
9-11, Drumul Taberei Street
Sector 6
061353 Bucharest

SLOVAKIA

Akadémia ozbrojených síl gen
M.R. Štefánika, Distribučné a
informačné stredisko STO
Demänová 393
031 06 Liptovský Mikuláš 6

SLOVENIA

Ministry of Defence
Central Registry for EU & NATO
Vojkova 55
1000 Ljubljana

SPAIN

Área de Cooperación Internacional en I+D
SDGPLATIN (DGAM)
C/ Arturo Soria 289
28033 Madrid

TURKEY

Milli Savunma Bakanlığı (MSB)
ARGE ve Teknoloji Dairesi Başkanlığı
06650 Bakanlıklar – Ankara

UNITED KINGDOM

Dstl Records Centre
Rm G02, ISAT F, Building 5
Dstl Porton Down, Salisbury SP4 0JQ

UNITED STATES

Defense Technical Information Center
8725 John J. Kingman Road
Fort Belvoir, VA 22060-6218

SALES AGENCIES

**The British Library Document
Supply Centre**
Boston Spa, Wetherby
West Yorkshire LS23 7BQ
UNITED KINGDOM

**Canada Institute for Scientific and
Technical Information (CISTI)**
National Research Council Acquisitions
Montreal Road, Building M-55
Ottawa, Ontario K1A 0S2
CANADA

Requests for STO, RTO or AGARD documents should include the word 'STO', 'RTO' or 'AGARD', as appropriate, followed by the serial number (for example AGARD-AG-315). Collateral information such as title and publication date is desirable. Full bibliographical references and abstracts of STO, RTO and AGARD publications are given in "NTIS Publications Database" (<http://www.ntis.gov>).